

**BOULEVARD 1 PANELS**

**Features**

- Desk height power and data management
- Patented "Knuckle-Loc," rigid connection, prevents light and sound transmission
- Built-in acoustical/tackable properties
- Sectional multi-accent design options
- Fabric surfaces are able to be replaced on-site
- Frame incorporates 1" centered slots for component adjustability
- Requires no additional top caps, end caps, trim caps, hinges, kick plates or clips
- Simple to specify
- Reduced installation time
- Easy to reconfigure
- High-tech look/stackable grid appearance
- Rigid, no sway, straight panel sight line
- Self levelers reduce assembly time, ensure even height
- Over panels extend to 10 feet to enclose an office in fabric and glazed options
- Patented Raceway cover easily removed
- Raceway panels top and bottom portion semi tackable

**Construction**

- Rigid extruded aluminum, finished frame, self-leveling 2 5/8" thick panel
- 1 1/8" sound absorbent Mineral Wool each side of hardboard septum

**Sizes**

- 8 Heights: 29", 37", 42", 50", 54", 58", 66" 74" and 82"
- 9 Widths: 6", 18" to 60" in 6" increments, 72" wide in selected panel configurations.

**Adjustability**

- 3" glide stem permits 2 1/2" height adjustment
- Slotted at 1" increments
- Over panels, 8", 16", 24", 37" and 42" for enclosed offices (Non-slotted)

**Acoustic Rating**

.80NRC/26STC

**Door**

- 2 door panel widths, glazed/unglazed, lockable, reversible
- 2 sliding door widths, non-lockable

**Flexibility**

- Universal connector

**Panel Finishes**

- 2 grades of fabric, air flow grill, glaze, tempered glass, laminate & COM

**Electrical**

- Desk height 8 wire/4 circuit - 1 dedicated

**Communication**

- Desk height data channel
- Raceway cover easily removed
- Fabric covered raceways available

**SYSTEM 3 PANELS**

**Features**

- Base power and data lay-in
- Desk height power and data feed thru
- Top data lay-in
- Patented "Knuckle-Loc," rigid connection, prevents light and sound transmission
- Removable multi-functional tile design options
- Fabric surfaces are able to be replaced on-site
- Reduced installation time
- Easy to reconfigure
- High-tech look/stackable grid appearance
- Rigid, no sway, straight panel sight line
- Self levelers reduce assembly time, ensure even height
- Over panels extend height to enclose an office in fabric, glazed or laminate options
- Raceway cover easily removed

**Construction**

- Rigid extruded aluminum

**Sizes**

- 5 Heights: 34", 42", 50", 54", 66"
- 8 Widths: 18" to 60"

**Adjustability**

- 3" glide stem permits 2 1/2" height adjustment
- Slotted at 1" centers
- Over panels, 8" and 16" (Non-slotted)

**Door**

- 2 widths, glazed/solid, lockable, reversible
- 2 sliding door widths, non-lockable

**Flexibility**

- Universal connector

**Panel Finishes**

- Fabric, air flow accessory, tempered glass, laminate, whiteboard, corkboard (at base only)

**ELECTRICAL FOR BOULEVARD 1 PANELS**

**Features**

- Customized power capabilities in each panel
- State-of-the-art snap-in electrical
- 8 wire with 3 regular 15 AMP circuits and 1 isolated 15 AMP circuit.
- 3N and 8K electrical available upon request.
- Snap-in installation - harnesses, junction boxes, duplexes
- Accessibility makes changing circuits easy
- Flexibility in choice of duplexes within panel: choice of circuits for each duplex; choice of quantity of duplexes (1 or 2 duplexes per panel)

- Electrical cords are concealed
- Separate large channel for data
- Change electrical without moving pedestals
- Lower installation/reconfiguration costs
- Data terminals snap into cable holder
- Floor or ceiling feed
- Duplexes accessible from both sides

**ELECTRICAL FOR SYSTEM 3 PANELS**

**Features**

- Customized power capabilities in each panel
- State-of-the-art snap-in duplex receptacles
- 8 wire with 3 regular 15 AMP circuits and 1 isolated 15 AMP circuit
- Snap-in installation - harnesses, junction boxes, duplexes

- Accessibility makes changing circuits easy
- Flexibility in choice of duplexes within panel
- Data terminals snap into base raceway cover and mid panel electrical tile
- Floor or ceiling feed
- Duplexes accessible from both sides

**WORKSURFACES / HARDWARE****Features**

- One universal cantilever support
- Pedestal eliminates need for end panel/cantilever
- Grommets are not needed
- Continuous cable accessibility across back
- Adjustable to any height, in 1" increments.
- Flush abutment side edge minimize seam crevice
- Metal-to-metal connections (Metal Inserts)
- Additional cable manager under worksurface

**Construction**

- Medium-density particle board 1 1/16" thick

**Sizes**

- 3 Depths: 18", 24" and 30"
- 12 Widths: 18" to 84" in 6" increments

**Finishes**

- Tops: High Pressure Laminate, Low Pressure Laminate or Wood
- Edges: Edge banded PVC or Wood

**Types**

- Transaction, keyboard, rectangular worksurface, corner, curved, D-top, P-top, Arc-top and freestanding

**OVERHEAD STORAGE****Features**

- Completely enclosed unit for 16" overheads
- Shipped fully assembled or KD
- 13.5" inside height for oversized binders
- Metal-to-metal connection
- Lock secures into bottom shelf
- Doors operate smoothly
- Flipper door retrofittable on site
- Safety bracket used for extra support
- Reinforcement built in for larger unit
- Can be removed and reconfigured without disassembly

**Fronts**

- Open or closed fronts

**Sizes**

- Overheads - 6 widths in 6" increments
- Shelves - 7 widths in 6" increments
- 16" deep welded overhead for EDP, ring binder, letter/legal
- 12" deep KD overhead
- 15" deep KD overhead with "soft-to-the-touch" handles

**Paint**

- Dry epoxy powder coating

**PEDESTALS****Features**

- Double wall construction on all drawer fronts
- Fully progressive suspension system
- Full-width pull, "Hytrel®" or "soft-to-the-touch" handles on drawer fronts
- Worksurface supporting option
- Full extension roller bearing glides on all file drawers
- Rubber bumpers for quietness
- Movable drawer divider/pencil tray
- 25" filing capacity for file drawers (only in 30" pedestal)
- Durable epoxy finish
- Keyed alike options
- Box/Box/File standard with pencil tray

**Construction**

- Double wall drawer fronts
- 18-20 gauge steel

**Sizes**

- 18", 24", 30" depth

**Types**

- Worksurface-Supporting, Mobile, Freestanding

**Paint**

- Dry epoxy powder coating

**HOW BOULEVARD 1 CAN REDUCE YOUR COSTS**

**Finished Panel**

- No inventory costs for connectors, trim caps, top caps, kick plates and clips.
- Less time required to install, or to disassemble, move and re-install.

**Fewer Parts**

- Only 1 universal cantilever and 3 brackets are needed to build most workstations.
- Easy to attach and remove components from panels.
- Universal post for 2-way, 3-way and 4-way applications.

**Desk Height Electric**

- Ease of initial electrical installation lowers energy management costs.
- Snap-in electrical components reduce reconfiguration costs.
- Can customize power in each panel, pay only for what is required.

**Simplified Specifications**

- Fewer parts and components make specifying, ordering, and verifying less work.
- Product fits a 6" planning module.

**Replaceable Panels**

- Panels can be re-upholstered on site.

**Communications/Data Channel**

- Desk height data channel reduces time to install and change cables.

**Floor to Ceiling Enclosed Office:**

- Re-usable enclosed offices with doors eliminate future costs for drywall demolition, new construction, mess and extensive cash flow.
- Depreciation expense indirectly increases cash flow.

**Warranty**

- Limited Lifetime Warranty on materials and workmanship.

**Product**

- Priced less than most other "A" Grade panel systems.

**HOW BOULEVARD SYSTEM 3 CAN REDUCE YOUR COSTS**

**Finished Panel**

- No inventory costs for connectors, top caps, kick plates and clips.
- Less time required to install, or to disassemble, move and re-install.

**Fewer Parts**

- Only 1 universal cantilever and 3 brackets are needed to build most workstations.
- Easy to attach and remove components from panels.
- Universal post for 2-way, 3-way and 4-way applications.

**Base Panel Electric System**

- Ease of initial electrical installation lowers energy management costs.
- Snap-in electrical components reduce reconfigurations costs.
- Can customize power in each panel, pay only for what is required.

**Simplified Specifications**

- Fewer parts and components make specifying, ordering, and verifying less work.
- Product fits a 6" planning module.

**Replaceable Panel Tiles**

- Over Panels and face tiles can be added and interchanged as needs change.

**Communications/Data Channel**

- Base and top lay-in communications channel reduces time to install and change cables.

**Warranty**

- Limited Lifetime Warranty on materials and workmanship.

**Product**

- Priced less than most other "A" Grade panel systems.

**VALUE-ADDED BENEFITS**

On the following pages, we selected a grouping of Boulevard 1, System 3 configurations, some with electrical components and task lights, to give you a better understanding of our product's specifications as they relate to workstations. Our objective is to not only illustrate applications using panels and components, but also to have this serve as a pricing exercise.

**All of the value-added benefits of the Boulevard 1 are standard as follows:**

- Desk height power and data capabilities.
- Finished panel including top, corner and end caps.
- Sectional panel with multiple fabric options.
- Ease of installation and reconfigurations.
- Removable fabric for on-site refurbishing.
- Exceptional storage capacity in pedestals, overheads, lateral files, storage cabinets and towers.
- Simplified specifications.

**All of the value-added benefits of the Boulevard System 3 are standard as follows:**

- Base power and data capabilities.
- Finished panel including top and corner.
- Monolithic or Pass-Thru panels with multiple fabric options.

- Ease of installation and reconfiguration.
- Removable fabric tiles in Pass-Thru Panels for on-site refurbishing.
- Exceptional storage capacity in pedestals, overheads, lateral files, storage cabinets and towers.
- Simplified specifications.

**All of the value-added benefits of the Diet System are standard as follows:**

- Finished panel including top, corner and end caps.
- Sectional panels with multiple fabric options.
- Ease of installation and reconfigurations.
- Removable fabric for on-site refurbishing.
- Exceptional storage capacity in pedestals, overheads, lateral files, storage cabinets and towers.
- Simplified specifications.

**When specifying Boulevard 1, Boulevard System 3 or Diet, you benefit from the ability to:**

- Customize the energy management.
- Minimize the number of necessary parts.
- Offer a competitive list price.

NOTE: If Key Alike Instructions are not submitted to GLOBAL CONTRACT with the Customer's Purchase Order, all components will be keyed randomly.

**WOOD GRAIN (WG) LAMINATE DIRECTION**

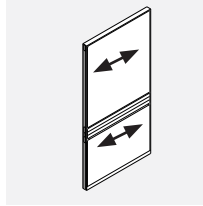

\* Panel general direction will default to vertical if monolithic panel is 54" high and if raceway panels are on same order.

All Panels  
With Exception of 66" or higher panels, the grain is vertical.

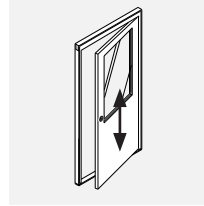

**BPD**  
Doors.

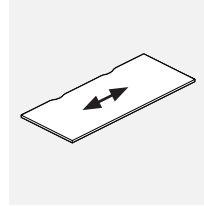

**BWS**  
Worksurfaces.

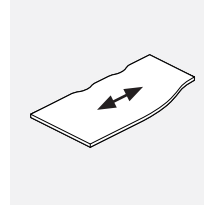

**BWSC**  
Worksurfaces.

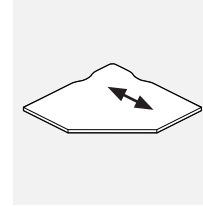

**BWCF**  
Corner Worksurfaces.

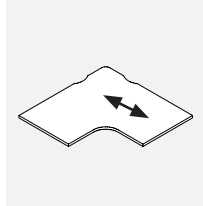

**BWCL**  
Corner Worksurfaces.

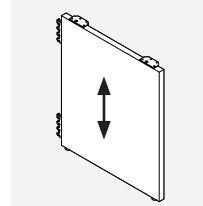

**BHFG**  
Full Gable.

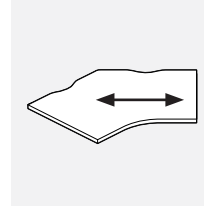

**BWAC** Angled Corner  
Worksurfaces

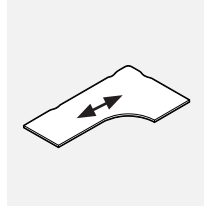

**BWCE**  
Extended Worksurfaces.

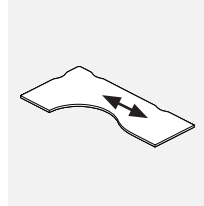

**BWCEC**  
Extended Worksurfaces.

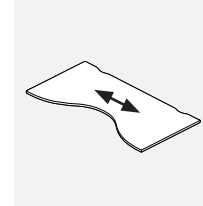

**BWBT**  
Bow Tie Worksurfaces.

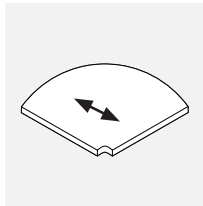

**BWR**  
Radius Worksurfaces.

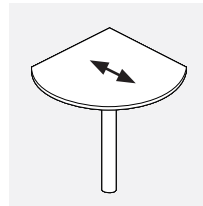

**BWRTD**  
Teardrop Worksurfaces.

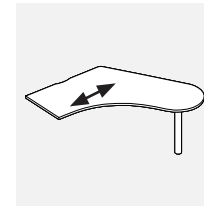

**BWC**  
Extended "D"  
Worksurfaces.

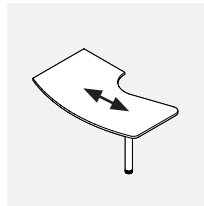

**BWSL**  
Curvilinear  
Worksurfaces.

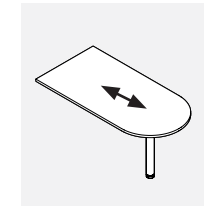

**BWD**  
Worksurfaces.

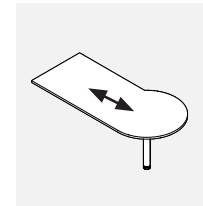

**BWP**  
Worksurfaces.

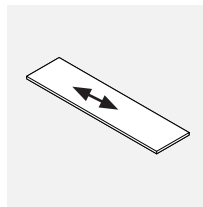

**BWT**  
Transaction  
Worksurfaces.

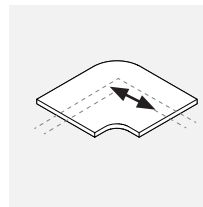

**BWTC**  
Corner Transaction  
Worksurfaces.



**BWTT**  
Transaction  
Worksurfaces.

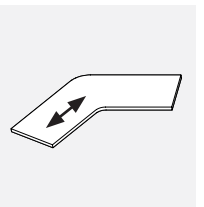

**BWTAC**  
Transaction  
Worksurfaces.

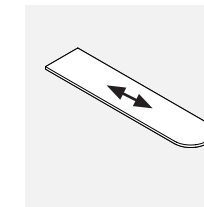

**BWTD "D"**  
Transaction  
Worksurfaces.

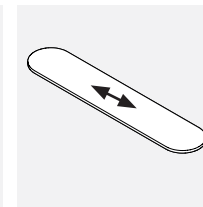

**BWTD "D"**  
Transaction  
Worksurfaces.

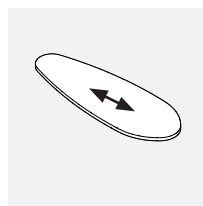

**BWTE**  
Ellipse Transaction  
Worksurfaces

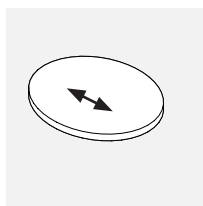

**BWTP**  
Round Transaction  
Worksurfaces.

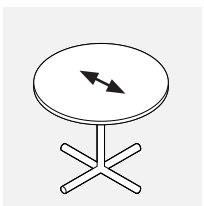

**BWCD**  
Round Tables.

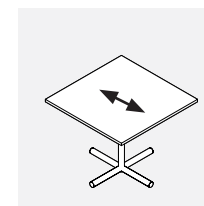

**BWSQ**  
Square Tables.

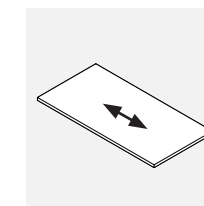

**BK**  
Desking Worksurfaces.

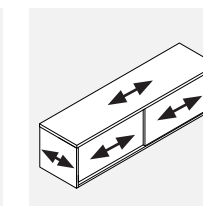

**BSP**  
Laminate Divider  
Storage

## BOULEVARD 1 PANEL SYSTEM

The Boulevard philosophy is based on simplicity. A product that is simple to install... simple to reconfigure... and simple to specify, without sacrificing delivery time or quality.

Technically superb and exceptionally precise aluminum extrusion and die-cast fittings achieve exact levels of consistency, panel after panel; everything fits, aligns, and assembles, first time, every time. Most of all it requires very few of the "small parts" associated with most systems. This cross-market integration is celebrated in Boulevard.

Truly a system of broad application, whether installed in a high-tech environment, factory application or executive office, Boulevard will perform! We invite you to share with us a product designed, built and marketed for a global economy.

### Our Mission

Our mission is to continue to develop and offer innovative, quality office furniture to value-oriented customers, through a dealer network that provides consistent, high quality service. Our approach in the contract furniture industry is to focus on customer concerns and needs to develop products that minimize your costs of ownership. It represents the culmination of creativity, industry expertise, specialists,

and integrity to help you achieve cost-effective solutions to problems. Our vision is to create a company-wide environment that supports constant improvement and promotes customer satisfaction. We believe that as good as we are today, we must be better tomorrow. Thus, our desire to improve is both continuous and tireless.

### Environmental Commitment

At Teknion, protecting the next generations' environment is of paramount concern. Teknion believes that it is our responsibility to help protect the environment for future generations. We continue to operate with the environment in mind, making wise business decisions that help protect the earth and its precious natural resources. Our manufacturing procedure incorporates the latest technology for painting products, using a dry epoxy powder or gel paint. This process produces no toxic residue, and therefore is environmentally safe, while other manufacturers still use the wet paint process. Our packaging, veneer selections, and reduction in waste programs all contribute to a better environment. In addition, our concern for the reduction of finishing emissions and wood dust has resulted in a healthier work environment in many ways, including this price book, printed on recycled paper.

## TECHNICAL INFORMATION

### Panels

- All panels are 2 5/8" thick.
- Lightweight aluminum box frame construction creates superior panel rigidity.
- Panel frame finish is durable epoxy powder coated.
- Hang-on capabilities at 1" increments.
- Patented "Knuckle-Loc" design provides solid panel-to-panel connection for fast installation and reconfiguration.
- Knuckle lock feature ensures even panel heights throughout installation.
- 3" glide stem permits 2 1/2" height adjustment.
- Panel sizes are actual, eliminating creepage.
- Panels come complete, eliminating need for separate top, corner end trim and clips.
- Fabric is replaceable on site.
- All panels include 2 "Capture Strip" panel connectors.
- Fabric retainer is clear.
- Panels are UL listed and CSA approved and have a Class "A" fire rating except when Customer's Own Material (COM) is used.
- Glazing available in acrylic or tempered glass for straight panels.
- Center septum above raceway overlaid on either side with tackable, 1 1/8" "Sound Absorbent Mineral Board."
- For glazing - Smoke developed index 500.
- For tempered glass, add "TG" to the end of the product code and add 20% to the price regardless of fabric grade.
- Solid metal sheet is an OPT option and price accordingly, however, the sheets are 48" wide and cannot be specified on 48" and wider unless they are railroaded. Contact your Customer Service Representative for more information.

### Panel Options

- Laminate, whiteboard, or corkboard may be substituted for fabric on panels only, not raceways, see "OPT" column.
- Laminate and whiteboard are held in place with a PVC retainer matching the frame color and can be retrofitted on site.
- Laminate and whiteboard options reduce the acoustical value of the panel.

### Raceway Options

- Raceways are standard in PVC matching the panel frame finish.
- Fabric-Covered Raceway (FRC) available. Aluminum raceway available.
- Wood veneer raceway available.
- Face-mount electrical raceway available.
- Face-mount openings are 1.5" x 2.85" for electrical and 1.37" x 2.755" for data.
- Cable capacity in raceways is 83 - 0.220" dia. cables (cat.6).

### Desk Height Management

- Desk height electrical and communication raceway system.

- State-of-the-art engineering.
- Snap-in modularity of all electrical components including harnesses, junction boxes, duplexes and circuit designations.
- All power and data outlets are easily accessible from both sides of panel.
- 8 wire system with 4, 15 amp circuits (including 1 dedicated circuit).
- Optional face-mount electrical with 2 duplexes per panel side.
- Outlet and circuit changes accomplished without disruption to workstation.
- Large raceway cavity permits storage of excess cables and equipment cords.
- Total flexibility for 8 wire system: choice of 1, 2 or 4 duplexes per panel; choice of circuitry in each duplex .
- Unique design of fire retardant PVC raceway cover permits access to raceway without disruption to equipment on worksurfaces.
- Clip-on communication management channel (BECC01 and BPH001) included with each raceway panel.
- Communication management channel accepts modular Data/Comm terminals (not supplied by Teknion Inc.).

### Posts

- Enables connection for multiple panel runs such as 90°, 45° or 60° angles and 2 way, 3 way or 4 way.
- Provides route for base, ceiling, and worksurface cable entry to a panel.
- Self leveling feature maintains even height of all connected panels.
- Solid lightweight aluminum extrusion fits together through a unique "Knuckle-Loc" design providing rigid post-to-panel connection.
- Includes all required panel connectors and caps.
- Posts add 2 5/8" to a panel run.
- Posts are 1/8" oversized to allow for "panel wrap around" of freestanding desks.
- For all panel runs with multiple posts, this 1/8" must be allotted for.

**PANELS - GUIDELINES FOR ORDERING PRODUCT**

**Codes**

The product guide uses a numbering system with meaningful alphanumeric characters to create a simple-to-understand product number. This makes specifying the product much easier and more accurate.

Example of Panel: **BPRA6636 CHR CHR**

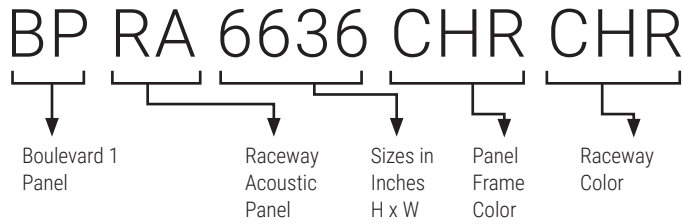

- AN50 Inside Lower Fabric
- AN50 Inside Upper Fabric
- BE21 Outside Lower Fabric
- BE21 Outside Upper Fabric

**How to Specify**

Specify Boulevard 1 panel type and size by code.  
 Specify panel frame finish - ie. CHR (Charcoal).  
 Specify PVC raceway finish - ie. CHR (Charcoal). If PVC raceway color not specified at time of order, default will be the panel frame color.  
 Specify all four panel fabric options if necessary.  
 Some fabrics have directional pattern and cannot be applied horizontally or vertically. Panels wider than 60" will have fabrics applied horizontally (railroad).  
 Please specify if you want adjacent panels and the rest of the installation upholstered the same way.

Example of Post: **BHP066 CHR**

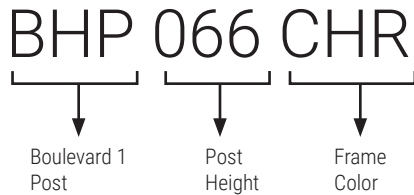

**How to Specify**

Specify Boulevard 1 post by code.  
 Specify frame color - ie. CHR (Charcoal).

**Raceways**

**PVC:**

Standard, at time of order, includes 2 covers.  
 Standard, when ordering individuals: RCSxxCOL.  
 Face-mount raceways: RCWxxD.

**Fabric:**

Standard, at time of order: RCWxxFAB, \$33 per side, sold as pair, panel-mounted.  
 Standard, when ordering individuals: 1006FRCxx, shipped separately.  
 Face-mount raceways: FCRxxD.

**Aluminum:**

Standard, when ordering individuals: BARCxx,  
 Face-mount raceways: RCAxxD.

**ORDERS**

**Each Order Must Include:**

- Purchase Order
- Layout showing where the image(s) appear in the run of panels.
- A completed Price Chart, showing the location of the image(s) on each appropriate panel.

• Artwork must be submitted in accordance with the following artwork specifications.

**NOTE:** Final artwork specification approval must be given before order can be processed.

**Transfer Devices**

- E-mail up to 10MB to your Teknion Customer Service Representative.
- Courier CD/DVD/USB stick to your Teknion Customer Service Representative.

**ARTWORK SPECIFICATIONS**

Non-Photographic artwork should be vector art, saved in Adobe Illustrator (.ai) or as an EPS (.eps)

All bitmap or photographic artwork has to be at a minimum of 100 dpi at the full size of the panel to be printed.

We accept Adobe CS5 files.

Any linked files must be included or imbedded.

Leave any PSD files unflattened

All fonts must be converted to outlines.

Do not convert to CMYK, leave all images as RGB if possible

No Word, Powerpoint, Publisher or other Microsoft files can be used.

Include a PDF or .jpg for reference when sending native Photoshop or Illustrator format files.

**COLOR MATCHING**

A Pantone color reference must be supplied or we cannot accept responsibility for correct color.

When it is not possible to refer to Pantone colors, we will do our best to meet your requirements.

**IMAGE CLARITY**

We will advise should the selected image not lend itself to the element size requested.

**NOTE**

We reserve the right to put an order on hold when the files are found to be incomplete or when documents have been either incorrectly saved. Fonts not

converted to curves or the job appears not to be commercially acceptable.

**IMAGE BLEED**

To facilitate placement on the panel. Extension of the image past the finished visible area of the panel (bleed) is required

• Boulevard Panels need a 5" Bleed on all sides.

**EXAMPLE OF IMAGE RESOLUTION**

The resolution required for a 36" wide x 24" high Boulevard panel at 100 dpi (minimum resolution)

The resolution required for a 36 wide x 24 high Boulevard panel at 300 dpi (higher quality)

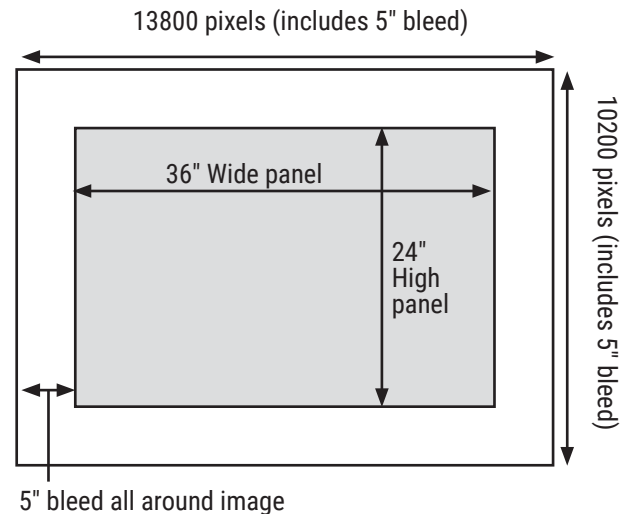
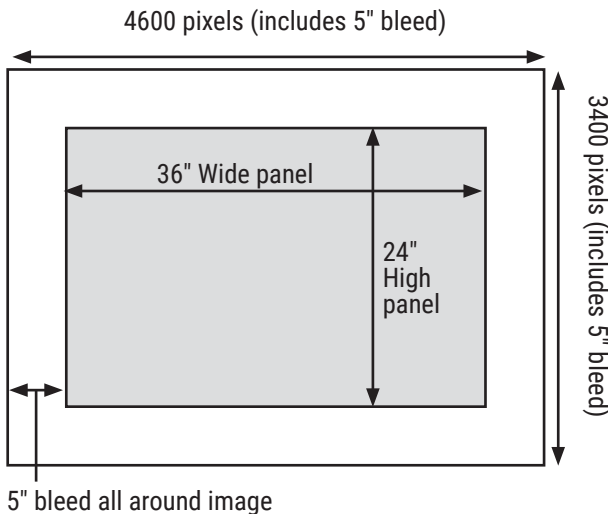

**Pricing, Initial Set-Up Charge per Order: \$235 net**

**Boulevard 1 Panels • Below Raceway Only**

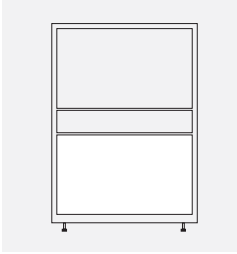

- This List applies to the following panels:
- BPRAXxxx
- BPRGXxxx
- BPRPxxxx
- BPARxxxx

PANEL HEIGHT	PANEL WIDTH	LIST PRICE
29"	24"	411
29"	30"	480
29"	36"	561
29"	42"	632
29"	48"	711
29"	54"	782
29"	60"	852
29"	66"	921
29"	72"	993

**Boulevard 1 • Above Raceway Only**

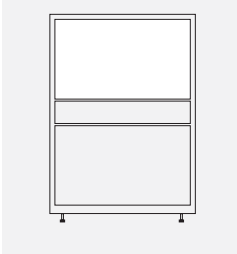

- This List applies to the following panels:
- BPRAXxxx
- BPRFxxxx

PANEL WIDTH	HEIGHT	LIST PRICE						
		42"	50"	54"	58"	66"	74"	82"
24"	N/A	248	290	331	421	512	592	
30"	N/A	292	334	390	501	600	701	
36"	N/A	341	395	450	572	691	811	
42"	N/A	381	450	520	651	782	921	
48"	N/A	431	508	581	732	880	1052	
54"	N/A	471	551	632	800	971	1132	
60"	N/A	512	600	691	881	1060	1241	
66"	N/A	551						
72"	N/A	600						

**Boulevard Fabric Acoustic Panels**

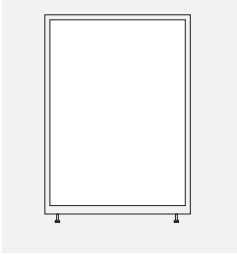

- This List applies to the following panels:
- BPFAXxxx

PANEL WIDTH	HEIGHT	LIST PRICE						
		42"	50"	54"	58"	66"	74"	82"
24"	540	632	678	722	800	892	981	
30"	641	741	797	852	952	1052	1153	
36"	741	860	921	981	1101	1213	1333	
42"	841	971	1042	1112	1241	1382	1512	
48"	941	1091	1169	1241	1392	1543	1693	
54"	1042	1203	1289	1373	1532	1701	1872	
60"	1132	1321	1413	1502	1683	1862	2041	
66"	1221	1413						
72"	1321	1532						

**Boulevard 1 Over Panels**

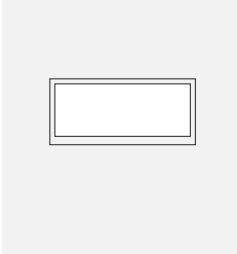

- This List applies to the following Panels:
- BPOFxxxx

PANEL WIDTH	HEIGHT		LIST PRICE			
	8"	16"	24"	37"	42"	
24"	191	280	361	501	561	
30"	226	331	431	592	660	
36"	260	381	491	681	761	
42"	301	431	561	782	860	
48"	331	480	621	860	961	
54"	372	540	691	961	1060	
60"	401	592	751	1052	1162	
66"	431	632	811	1132	1252	
72"	471	681	871	1221	1351	

Note: Prices shown are an upcharge to the panel price, please add to the list price of panel which you are specifying the graphic for.



**BPRA • Acoustical Raceway Panel**

- Fabric above the raceway provides visual and acoustic privacy.
- Center septum above and below raceway overlaid on either side with tackable, 1 1/8" "Sound absorbent mineral board."
- Center septum below raceway overlaid on either side with 1 1/8" Mineral board.
- Acoustic rating of .80 NRC and 26 STC.
- OPT\* = Laminate or Whiteboard.

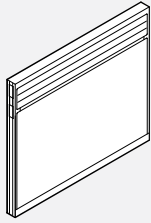

37" High

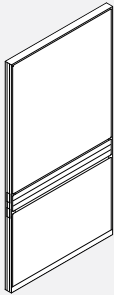

72" Wide

PRODUCT CODE	PRICE			SIZE/INCHES			WEIGHT VOL	
	GR1	GR2	OPT*	H	W	D	LBS	FT <sup>3</sup>
BPRA3718	473	482	497	37	18	2.61	18	1.58
BPRA3724	524	536	547	37	24	2.61	21	2.054
BPRA3730	576	588	601	37	30	2.61	25	2.528
BPRA3736	626	670	717	37	36	2.61	28	3.002
BPRA3742	681	727	772	37	42	2.61	32	3.476
BPRA3748	732	776	820	37	48	2.61	35	3.950
BPRA3754	786	830	875	37	54	2.61	39	4.424
BPRA3760	835	881	925	37	60	2.61	44	4.898
BPRA3766	1111	1165	1220	37	66	2.61	50	5.499
BPRA3772	1387	1440	1495	37	72	2.61	56	6.000
BPRA4218	473	497	523	42	18	2.61	22	1.782
BPRA4224	524	550	578	42	24	2.61	28	2.317
BPRA4230	576	600	627	42	30	2.61	32	2.852
BPRA4236	626	678	732	42	36	2.61	36	3.387
BPRA4242	681	733	786	42	42	2.61	40	3.921
BPRA4248	734	789	835	42	48	2.61	44	4.456
BPRA4254	786	836	891	42	54	2.61	48	4.991
BPRA4260	835	886	940	42	60	2.61	52	5.525
BPRA4266	1199	1305	1420	42	66	2.61	62	6.148
BPRA4272	1565	1671	1783	42	72	2.61	72	6.770
BPRA5018	536	562	589	50	18	2.61	25	2.106
BPRA5024	590	627	669	50	24	2.61	30	2.738
BPRA5030	647	685	728	50	30	2.61	35	3.370
BPRA5036	705	767	835	50	36	2.61	40	4.002
BPRA5042	757	820	891	50	42	2.61	45	4.634
BPRA5048	816	879	946	50	48	2.61	50	5.266
BPRA5054	869	932	1002	50	54	2.61	55	5.898
BPRA5060	928	992	1058	50	60	2.61	60	6.530
BPRA5066	1270	1377	1489	50	66	2.61	70	7.300
BPRA5072	1612	1718	1830	50	72	2.61	80	8.000
BPRA5418	582	605	635	54	18	2.61	27	2.250
BPRA5424	641	679	719	54	24	2.61	32	2.960
BPRA5430	696	733	775	54	30	2.61	37	3.689
BPRA5436	752	830	910	54	36	2.61	42	4.318
BPRA5442	814	891	970	54	42	2.61	47	4.934
BPRA5448	868	944	1025	54	48	2.61	52	5.666
BPRA5454	928	1004	1084	54	54	2.61	59	6.398
BPRA5460	982	1058	1139	54	60	2.61	62	7.035

**BPRA • Acoustical Raceway Panel ... Continued**

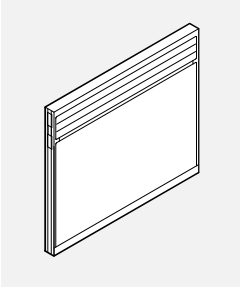

37" High

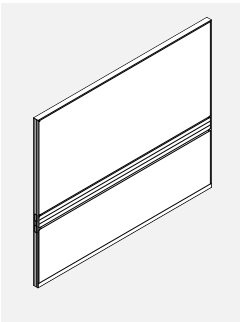
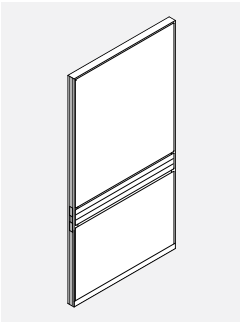

72" Wide

- Fabric above the raceway provides visual and acoustic privacy.
- Center septum above and below raceway overlaid on either side with tackable, 1 1/8" "Sound absorbent mineral board."
- Center septum below raceway overlaid on either side with 1 1/8" Mineral board.
- Acoustic rating of .80 NRC and 26 STC.
- OPT\* = Laminate or Whiteboard.

PRODUCT CODE	PRICE			SIZE/INCHES			WEIGHT VOL	
	GR1	GR2	OPT*	H	W	D	LBS	FT <sup>3</sup>
BPRA5818	582	605	635	58	18	2.61	28	2.431
BPRA5824	641	679	719	58	24	2.61	33	3.160
BPRA5830	696	733	775	58	30	2.61	38	3.889
BPRA5836	752	830	910	58	36	2.61	43	4.618
BPRA5842	814	891	970	58	42	2.61	48	5.347
BPRA5848	868	944	1025	58	48	2.61	53	6.076
BPRA5854	928	1004	1084	58	54	2.61	58	6.806
BPRA5860	982	1058	1139	58	60	2.61	63	7.535
BPRA6618	625	662	703	66	18	2.61	32	2.755
BPRA6624	685	736	789	66	24	2.61	37	3.581
BPRA6630	746	795	852	66	30	2.61	42	4.407
BPRA6636	804	892	986	66	36	2.61	48	5.234
BPRA6642	863	952	1048	66	42	2.61	53	6.060
BPRA6648	925	1014	1110	66	48	2.61	58	6.887
BPRA6654	981	1069	1164	66	54	2.61	63	7.713
BPRA6660	1040	1129	1224	66	60	2.61	68	8.539
BPRA7418	678	712	754	74	18	2.61	34	3.079
BPRA7424	735	786	840	74	24	2.61	39	4.002
BPRA7430	795	848	901	74	30	2.61	45	4.926
BPRA7436	859	961	1068	74	36	2.61	50	5.850
BPRA7442	922	1024	1130	74	42	2.61	55	6.773
BPRA7448	978	1079	1186	74	48	2.61	60	7.697
BPRA7454	1040	1142	1251	74	54	2.61	65	8.620
BPRA7460	1103	1204	1311	74	60	2.61	70	9.544
BPRA8218	732	767	810	82	18	2.61	36	3.403
BPRA8224	794	858	925	82	24	2.61	42	4.424
BPRA8230	859	922	992	82	30	2.61	48	5.444
BPRA8236	923	1036	1157	82	36	2.61	54	6.465
BPRA8242	982	1096	1219	82	42	2.61	60	7.486
BPRA8248	1048	1160	1279	82	48	2.61	66	8.507
BPRA8254	1111	1224	1345	82	54	2.61	72	9.528
BPRA8260	1176	1290	1409	82	60	2.61	78	10.549

**BPRG • Partly-Glazed Raceway Panel**

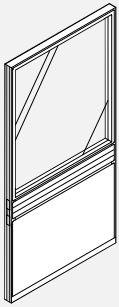

- Glazing above the raceway provides visual accessibility.
- Center septum below raceway overlaid on either side with 1 1/8" "Sound absorbent mineral board."
- Glazing replaceable on site.
- Standard glaze is acrylic.
- OPT\* = Laminate or Whiteboard.

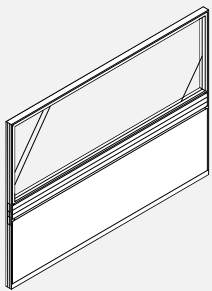

72" Wide

PRODUCT CODE	PRICE			SIZE/INCHES			WEIGHT VOL	
	GR1	GR2	OPT*	H	W	D	LBS	FT <sup>3</sup>
BPRG4218	635	644	660	42	18	2.61	22	1.782
BPRG4224	692	717	744	42	24	2.61	28	2.317
BPRG4230	751	778	805	42	30	2.61	32	2.852
BPRG4236	814	863	917	42	36	2.61	36	3.387
BPRG4242	869	921	973	42	42	2.61	40	3.921
BPRG4248	930	981	1035	42	48	2.61	44	4.456
BPRG4254	992	1040	1095	42	54	2.61	48	4.991
BPRG4260	1049	1100	1153	42	60	2.61	52	5.525
BPRG4266	1385	1437	1493	42	66	2.61	62	6.148
BPRG4272	1720	1772	1828	42	72	2.61	72	6.770
BPRG5018	702	712	729	50	18	2.61	24	2.106
BPRG5024	761	787	814	50	24	2.61	29	2.738
BPRG5030	824	851	875	50	30	2.61	34	3.370
BPRG5036	886	938	992	50	36	2.61	39	4.002
BPRG5042	944	995	1049	50	42	2.61	44	4.634
BPRG5048	1008	1058	1111	50	48	2.61	48	5.266
BPRG5054	1069	1119	1175	50	54	2.61	54	5.898
BPRG5060	1129	1180	1231	50	60	2.61	59	6.530
BPRG5066	1446	1501	1556	50	66	2.61	70	7.300
BPRG5072	1765	1818	1873	50	72	2.61	78	8.000
BPRG5418	741	752	767	54	18	2.61	27	2.250
BPRG5424	799	825	849	54	24	2.61	30	2.960
BPRG5430	862	887	914	54	30	2.61	35	3.689
BPRG5436	925	977	1030	54	36	2.61	40	4.318
BPRG5442	986	1037	1090	54	42	2.61	45	4.934
BPRG5448	1049	1100	1154	54	48	2.61	49	5.666
BPRG5454	1111	1162	1215	54	54	2.61	55	6.398
BPRG5460	1173	1224	1277	54	60	2.61	60	7.035
BPRG5818	778	789	805	58	18	2.61	26	2.431
BPRG5824	838	862	891	58	24	2.61	31	3.160
BPRG5830	901	925	954	58	30	2.61	36	3.889
BPRG5836	965	1015	1069	58	36	2.61	41	4.618
BPRG5842	1027	1078	1132	58	42	2.61	46	5.347
BPRG5848	1090	1140	1192	58	48	2.61	51	6.076
BPRG5854	1153	1203	1258	58	54	2.61	56	6.806
BPRG5860	1218	1267	1319	58	60	2.61	61	7.535
BPRG6618	842	854	868	66	18	2.61	29	2.755
BPRG6624	908	935	961	66	24	2.61	34	3.581
BPRG6630	975	1002	1027	66	30	2.61	39	4.407
BPRG6636	1043	1092	1145	66	36	2.61	45	5.234
BPRG6642	1111	1161	1216	66	42	2.61	50	6.060
BPRG6648	1178	1227	1279	66	48	2.61	55	6.887
BPRG6654	1241	1295	1346	66	54	2.61	60	7.713
BPRG6660	1313	1365	1420	66	60	2.61	65	8.539
BPRG7418	910	922	938	74	18	2.61	30	3.079
BPRG7424	981	1008	1033	74	24	2.61	35	4.002
BPRG7430	1052	1102	1155	74	30	2.61	41	4.926
BPRG7436	1121	1171	1224	74	36	2.61	46	5.850
BPRG7442	1191	1242	1296	74	42	2.61	51	6.773
BPRG7448	1264	1313	1369	74	48	2.61	56	7.697
BPRG7454	1335	1385	1437	74	54	2.61	61	8.620
BPRG7460	1418	1466	1520	74	60	2.61	66	9.544
BPRG8218	962	973	989	82	18	2.61	31	3.403
BPRG8224	1038	1065	1091	82	24	2.61	36	4.424
BPRG8230	1118	1143	1171	82	30	2.61	43	5.444
BPRG8236	1196	1250	1301	82	36	2.61	49	6.465
BPRG8242	1279	1331	1382	82	42	2.61	55	7.486
BPRG8248	1356	1407	1462	82	48	2.61	61	8.507
BPRG8254	1436	1486	1540	82	54	2.61	67	9.528
BPRG8260	1524	1575	1630	82	60	2.61	73	10.549

**BPRF • Air Flow Panel**

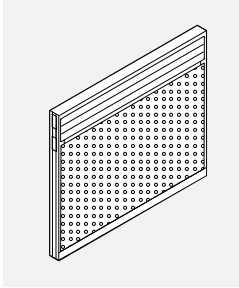

37" High

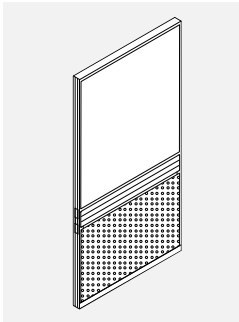

72" Wide

- Double wall of perforated metal below the raceway allows air to flow freely through the bottom of the panel.
- Center septum above raceway overlaid on either side with tackable, 1 1/8" "Sound absorbent mineral board."
- OPT\* = Laminate or Whiteboard.

PRODUCT CODE	PRICE			SIZE/INCHES			WEIGHT VOL	
	GR 1	GR 2	OPT*	H	W	D	LBS	FT <sup>3</sup>
BPRF3718	528			37	18	2.61	18	1.58
BPRF3724	598			37	24	2.61	21	2.054
BPRF3730	670			37	30	2.61	25	2.528
BPRF3736	744			37	36	2.61	28	3.002
BPRF3742	815			37	42	2.61	32	3.476
BPRF3748	886			37	48	2.61	35	3.950
BPRF3754	959			37	54	2.61	39	4.424
BPRF3760	1027			37	60	2.61	44	4.898
BPRF3766	1386			37	66	2.61	50	5.449
BPRF3772	1743			37	72	2.61	56	6.000
BPRF4218	545	550	557	42	18	2.61	22	1.782
BPRF4224	620	625	632	42	24	2.61	28	2.317
BPRF4230	692	698	705	42	30	2.61	32	2.852
BPRF4236	766	778	792	42	36	2.61	36	3.387
BPRF4242	840	852	865	42	42	2.61	40	3.921
BPRF4248	912	923	939	42	48	2.61	44	4.456
BPRF4254	988	999	1014	42	54	2.61	48	4.991
BPRF4260	1062	1073	1089	42	60	2.61	52	5.525
BPRF4266	1494	1549	1604	42	66	2.61	62	6.270
BPRF4272	1927	1981	2036	42	72	2.61	72	6.770
BPRF5018	609	624	638	50	18	2.61	25	2.106
BPRF5024	686	700	712	50	24	2.61	30	2.738
BPRF5030	765	777	790	50	30	2.61	35	3.370
BPRF5036	841	865	894	50	36	2.61	40	4.002
BPRF5042	922	946	973	50	42	2.61	45	4.634
BPRF5048	998	1024	1051	50	48	2.61	50	5.266
BPRF5054	1073	1100	1127	50	54	2.61	55	5.898
BPRF5060	1151	1177	1203	50	60	2.61	60	6.530
BPRF5066	1592	1645	1700	50	66	2.61	70	7.300
BPRF5072	2030	2083	2139	50	72	2.61	80	8.000
BPRF5418	655	675	693	54	18	2.61	27	2.250
BPRF5424	734	752	772	54	24	2.61	32	2.960
BPRF5430	815	835	854	54	30	2.61	37	3.689
BPRF5436	895	930	972	54	36	2.61	42	4.318
BPRF5442	971	1009	1051	54	42	2.61	47	4.934
BPRF5448	1051	1087	1129	54	48	2.61	52	5.666
BPRF5454	1129	1167	1209	54	54	2.61	57	6.398
BPRF5460	1213	1250	1291	54	60	2.61	62	7.035

**BPRF • Air Flow Panel ... Continued**

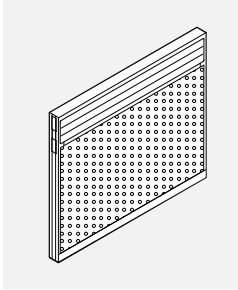

37" High

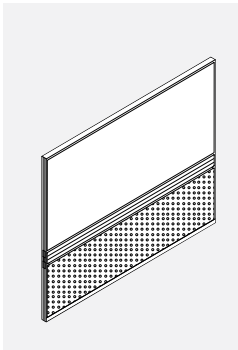
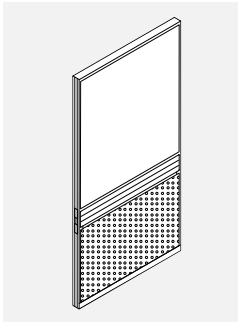

72" Wide

- Double wall of perforated metal below the raceway allows air to flow freely through the bottom of the panel.
- Center septum above raceway overlaid on either side with tackable, 1 1/8" "Sound absorbent mineral board."
- For air flow option above the raceway, add 20% to the Grade 1 price and tag each item with "air flow above raceway." For example: BPRF4218 TAG:\*air flow above raceway.
- OPT\* = Laminate or Whiteboard.

PRODUCT CODE	PRICE			SIZE/INCHES			WEIGHT VOL	
	GR1	GR2	OPT*	H	W	D	LBS	FT <sup>3</sup>
BPRF5818	655	674	693	58	18	2.61	28	2.431
BPRF5824	734	751	772	58	24	2.61	33	3.160
BPRF5830	815	833	854	58	30	2.61	38	3.889
BPRF5836	895	930	972	58	36	2.61	43	4.618
BPRF5842	971	1009	1051	58	42	2.61	48	5.347
BPRF5848	1051	1090	1130	58	48	2.61	53	6.076
BPRF5854	1129	1167	1209	58	54	2.61	58	6.806
BPRF5860	1213	1250	1291	58	60	2.61	63	7.535
BPRF6618	698	723	749	66	18	2.61	32	2.755
BPRF6624	783	808	833	66	24	2.61	37	3.581
BPRF6630	862	889	914	66	30	2.61	42	4.407
BPRF6636	941	986	1031	66	36	2.61	48	5.234
BPRF6642	1079	1124	1171	66	42	2.61	53	6.060
BPRF6648	1144	1188	1234	66	48	2.61	58	6.887
BPRF6654	1240	1289	1334	66	54	2.61	63	7.713
BPRF6660	1275	1319	1367	66	60	2.61	68	8.539
BPRF7418	749	775	800	74	18	2.61	34	3.079
BPRF7424	831	856	883	74	24	2.61	39	4.002
BPRF7430	912	938	964	74	30	2.61	45	4.926
BPRF7436	998	1059	1128	74	36	2.61	50	5.850
BPRF7442	1151	1214	1281	74	42	2.61	55	6.773
BPRF7448	1186	1250	1317	74	48	2.61	60	7.697
BPRF7454	1248	1311	1380	74	54	2.61	65	8.620
BPRF7460	1331	1392	1461	74	60	2.61	70	9.544
BPRF8218	805	842	884	82	18	2.61	36	3.403
BPRF8224	894	929	971	82	24	2.61	42	4.424
BPRF8230	973	1011	1053	82	30	2.61	48	5.444
BPRF8236	1070	1140	1215	82	36	2.61	54	6.465
BPRF8242	1186	1258	1332	82	42	2.61	60	7.486
BPRF8248	1240	1311	1385	82	48	2.61	66	8.507
BPRF8254	1377	1445	1517	82	54	2.61	72	9.528
BPRF8260	1403	1474	1548	82	60	2.61	78	10.549

**BPRAE • Raceway Panel Electrical**

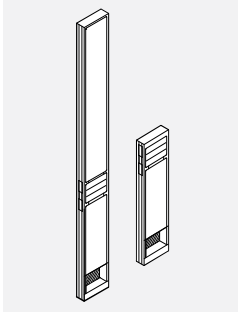

- A 6" raceway panel allows power and communication/data entry along a straight run of panels where a standard post entry cannot be utilized.
- Sections above and below the raceway are upholstered in fabric.
- Inner lower raceway area allows for single or double power feed entry and provides 1.3" x 2.9" opening for communication/data cables.
- All 6" panels must be used in conjunction with a second panel to form a standard panel width. For example: BPRAE6606 + BPRAE6618 is equivalent to BPRAE6624.
- 6" panels are not to be used as a stability panel in a panel run.

PRODUCT CODE	PRICE			SIZE/INCHES			WEIGHT VOL	
	GR1	GR2	OPT*	H	W	D	LBS	FT <sup>3</sup>
BPRAE3706	524	538	552	37	6	2.61	24	0.6
BPRAE4206	524	550	579	42	6	2.61	26	0.7
BPRAE5006	590	628	669	50	6	2.61	29	0.8
BPRAE5406	616	654	693	54	6	2.61	31	0.9
BPRAE5806	641	680	719	58	6	2.61	32	0.9
BPRAE6606	685	735	790	66	6	2.61	35	1.0
BPRAE7406	735	787	841	74	6	2.61	37	1.1
BPRAE8206	794	858	924	82	6	2.61	41	1.2

**BPRA • Raceway Panel Filler**

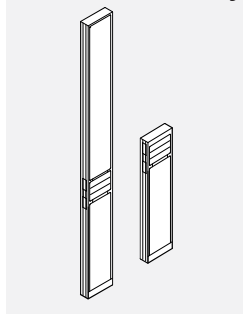

- A 6" (BPRA) raceway panel for use as a filler panel.
- Sections above and below the raceway are upholstered in fabric.
- All 6" panels must be used in conjunction with a second panel to form a standard panel width. For example: BPRA6606 + BPRA6618 is equivalent to BPRA6624.
- 6" panels are not to be used as a stability panel in a panel run.

PRODUCT CODE	PRICE			SIZE/INCHES			WEIGHT VOL	
	GR 1	GR 2	OPT*	H	W	D	LBS	FT <sup>3</sup>
BPRA3706	524	538	552	37	6	2.61	24	0.6
BPRA4206	524	550	579	42	6	2.61	26	0.7
BPRA5006	590	628	669	50	6	2.61	29	0.8
BPRA5406	616	652	693	54	6	2.61	31	0.9
BPRA5806	641	679	719	58	6	2.61	32	0.9
BPRA6606	685	735	789	66	6	2.61	35	1.0
BPRA7406	735	787	840	74	6	2.61	37	1.1
BPRA8206	794	857	924	82	6	2.61	41	1.2

**BPRP • Pass-Thru Raceway Panel**

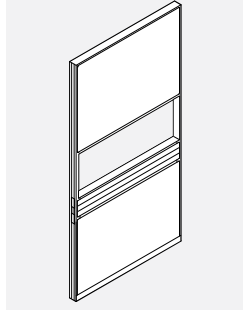

- 10.5" Open cavity allows accessibility between workstations.
- Center septum above 10.5" opening overlaid on either side with tackable, 1 1/8" mineral board.
- Center septum below raceway overlaid on either side with tackable, 1 1/8" mineral board.
- Pass-thru opening is 10 1/2" high starting above the raceway.
- Panel height to top of opening is fixed.

PRODUCT CODE	PRICE			SIZE/INCHES			WEIGHT VOL	
	GR 1	GR 2	OPT*	H	W	D	LBS	FT <sup>3</sup>
BPRP6618	842	854	868	66	18	2.61	32	2.755
BPRP6624	908	935	961	66	24	2.61	33	3.581
BPRP6630	975	1002	1027	66	30	2.61	38	4.407
BPRP6636	1043	1092	1145	66	36	2.61	44	5.234
BPRP6642	1111	1161	1216	66	42	2.61	49	6.060
BPRP6648	1178	1227	1279	66	48	2.61	54	6.887
BPRP6654	1241	1295	1346	66	54	2.61	59	7.713
BPRP6660	1313	1365	1420	66	60	2.61	64	8.539
BPRP7418	910	941	973	74	18	2.61	31	3.079
BPRP7424	981	1031	1086	74	24	2.61	36	4.002
BPRP7430	1052	1102	1155	74	30	2.61	42	4.926
BPRP7436	1121	1182	1251	74	36	2.61	47	5.850
BPRP7442	1191	1241	1297	74	42	2.61	52	6.773
BPRP7448	1261	1343	1432	74	48	2.61	57	7.697
BPRP7454	1335	1419	1507	74	54	2.61	62	8.620
BPRP7460	1418	1466	1520	74	60	2.61	67	9.544
BPRP8218	962	998	1037	82	18	2.61	34	3.403
BPRP8224	1038	1089	1140	82	24	2.61	40	4.424
BPRP8230	1118	1169	1220	82	30	2.61	46	5.444
BPRP8236	1196	1286	1381	82	36	2.61	52	6.465
BPRP8242	1275	1380	1485	82	42	2.61	58	7.486
BPRP8248	1356	1459	1565	82	48	2.61	64	8.507
BPRP8254	1436	1537	1645	82	54	2.61	70	9.528
BPRP8260	1524	1625	1732	82	60	2.61	76	10.549

**BPRPSD • Pass-Thru Sliding Door Kit**

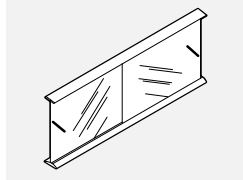

- To close the opening in a Boulevard 1 Pass-Thru Panel.
- Sliding frosted tempered glass doors.

PRODUCT CODE	PRICE	SIZE/INCHES			WEIGHT VOL	
		H	W	D	LBS	FT <sup>3</sup>
BPRPSD36	341	10	36	2.61	13	1.2
BPRPSD42	384	10	42	2.61	16	1.4
BPRPSD48	430	10	48	2.61	18	1.5
BPRPSD54	473	10	54	2.61	20	1.7
BPRPSD60	516	10	60	2.61	22	2.0

**BPAR • Accessory Rail Panel**

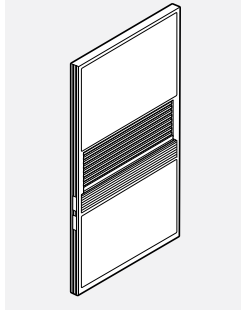

- 12" Accessory rail covers the standard pass-thru opening and allows users to hang accessories.
- Center septum above 12" opening overlaid on either side with tackable, 1 1/8" "Sound absorbent mineral board."
- Center septum below raceway overlaid on either side with 1 1/8" mineral board.
- Accessory rail is 12" high starting above the raceway. Panel height to top of opening is fixed.
- OPT\* = Laminate or Whiteboard.

PRODUCT CODE	PRICE			SIZE/INCHES			WEIGHT VOL	
	GR 1	GR 2	OPT*	H	W	D	LBS	FT <sup>3</sup>
BPAR6618	1035	1048	1062	66	18	2.61	35	2.755
BPAR6624	1124	1149	1177	66	24	2.61	42	3.581
BPAR6630	1231	1259	1286	66	30	2.61	49	4.407
BPAR6636	1348	1398	1452	66	36	2.61	57	5.234
BPAR6642	1489	1540	1594	66	42	2.61	65	6.060
BPAR6648	1601	1650	1704	66	48	2.61	72	6.887
BPAR6654	1718	1769	1821	66	54	2.61	79	7.713
BPAR6660	1825	1877	1930	66	60	2.61	86	8.539
BPAR7418	1103	1135	1169	74	18	2.61	38	3.079
BPAR7424	1194	1248	1300	74	24	2.61	45	4.002
BPAR7430	1306	1356	1413	74	30	2.61	53	4.926
BPAR7436	1429	1489	1489	74	36	2.61	60	5.850
BPAR7442	1440	1624	1677	74	42	2.61	68	6.773
BPAR7448	1688	1774	1867	74	48	2.61	75	7.697
BPAR7454	1807	1856	1909	74	54	2.61	82	8.620
BPAR7460	1926	1976	2030	74	60	2.61	89	9.544
BPAR8218	1153	1187	1227	82	18	2.61	41	3.403
BPAR8224	1256	1302	1353	82	24	2.61	49	4.424
BPAR8230	1376	1424	1475	82	30	2.61	57	5.444
BPAR8236	1505	1593	1688	82	36	2.61	65	6.465
BPAR8242	1658	1760	1866	82	42	2.61	74	7.486
BPAR8248	1781	1883	1990	82	48	2.61	82	8.507
BPAR8254	1907	2009	2117	82	54	2.61	90	9.528
BPAR8260	2034	2133	2241	82	60	2.61	98	10.549

**BPFA • Acoustical Fabric Panel**

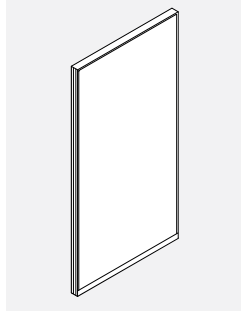

- Complete fabric panel without raceway.
- Acoustical rating of .80 NRC and 26 STC.
- Center septum overlaid on either side with 1 1/8" Mineral board, non tackable.
- OPT\* = Laminate or Whiteboard.

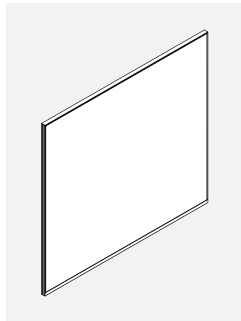

72" Wide

PRODUCT CODE	PRICE			SIZE/INCHES			WEIGHT VOL	
	GR 1	GR 2	OPT*	H	W	D	LBS	FT <sup>3</sup>
BPFA2918	323	349	374	29	18	2.61	15	1.256
BPFA2924	350	378	408	29	24	2.61	17	1.633
BPFA2930	373	398	425	29	30	2.61	19	2.009
BPFA2936	401	449	504	29	36	2.61	21	2.386
BPFA2942	425	476	529	29	42	2.61	23	2.763
BPFA2948	448	498	554	29	48	2.61	25	3.139
BPFA2954	475	525	579	29	54	2.61	27	3.513
BPFA2960	498	550	603	29	60	2.61	29	3.893
BPFA2966	644	698	754	29	66	2.61	36	4.332
BPFA2972	790	843	-	29	72	2.61	42	4.770
BPFA4218	425	449	477	42	18	2.61	18	1.782
BPFA4224	452	504	557	42	24	2.61	21	2.317
BPFA4230	477	528	582	42	30	2.61	24	2.852
BPFA4236	506	567	637	42	36	2.61	27	3.387
BPFA4242	531	595	663	42	42	2.61	30	3.921
BPFA4248	561	624	692	42	48	2.61	33	4.456
BPFA4254	587	647	717	42	54	2.61	36	4.991
BPFA4260	616	678	745	42	60	2.61	39	5.525
BPFA4266	875	981	1095	42	66	2.61	47	6.148
BPFA4272	1134	1241	-	42	72	2.61	54	6.770
BPFA5018	479	504	530	50	18	2.61	22	2.106
BPFA5024	509	546	588	50	24	2.61	25	2.738
BPFA5030	538	576	619	50	30	2.61	28	3.370
BPFA5036	566	642	723	50	36	2.61	31	4.002
BPFA5042	597	671	751	50	42	2.61	34	4.634
BPFA5048	624	700	781	50	48	2.61	38	5.266
BPFA5054	654	729	810	50	54	2.61	41	5.898
BPFA5060	682	757	840	50	60	2.61	43	6.530
BPFA5066	944	1049	1164	50	66	2.61	53	7.300
BPFA5072	1207	1311	-	50	72	2.61	62	8.000
BPFA5418	534	558	587	54	18	2.61	23	2.250
BPFA5424	565	601	643	54	24	2.61	26	2.960
BPFA5430	597	635	676	54	30	2.61	30	3.689
BPFA5436	625	701	782	54	36	2.61	34	4.318
BPFA5442	657	733	813	54	42	2.61	38	4.934
BPFA5448	686	762	842	54	48	2.61	41	5.666
BPFA5454	718	794	874	54	54	2.61	43	6.398
BPFA5460	750	826	907	54	60	2.61	46	7.035

**BPFA • Acoustical Fabric Panel ... Continued**

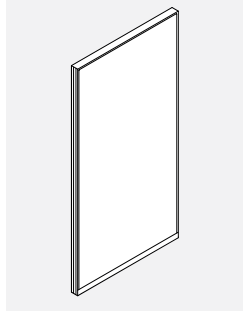

- Complete fabric panel without raceway.
- Acoustical rating of .80 NRC and 26 STC.
- Center septum overlaid on either side with 1 1/8" Mineral board, non tackable.
- OPT\* = Laminate or Whiteboard.

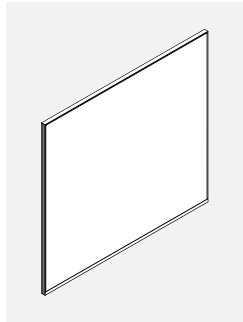

72" Wide

PRODUCT CODE	PRICE			SIZE/INCHES			WEIGHT VOL	
	GR1	GR2	OPT*	H	W	D	LBS	FT <sup>3</sup>
BPFA5818	534	571	612	58	18	2.61	24	2.431
BPFA5824	565	617	669	58	24	2.61	27	3.160
BPFA5830	597	646	701	58	30	2.61	31	3.889
BPFA5836	625	711	808	58	36	2.61	35	4.618
BPFA5842	657	744	840	58	42	2.61	39	5.347
BPFA5848	686	776	869	58	48	2.61	42	6.076
BPFA5854	718	806	901	58	54	2.61	46	6.806
BPFA5860	750	840	935	58	60	2.61	50	7.535
BPFA6618	583	621	662	66	18	2.61	26	2.755
BPFA6624	619	668	722	66	24	2.61	29	3.581
BPFA6630	652	702	754	66	30	2.61	34	4.407
BPFA6636	685	787	895	66	36	2.61	39	5.234
BPFA6642	719	820	928	66	42	2.61	43	6.060
BPFA6648	752	854	964	66	48	2.61	47	6.887
BPFA6654	788	891	997	66	54	2.61	51	7.713
BPFA6660	820	922	1029	66	60	2.61	55	8.539
BPFA7418	637	674	714	74	18	2.61	28	3.079
BPFA7424	676	739	806	74	24	2.61	32	4.002
BPFA7430	709	775	842	74	30	2.61	37	4.926
BPFA7436	746	859	981	74	36	2.61	42	5.850
BPFA7442	783	896	1016	74	42	2.61	47	6.773
BPFA7448	817	930	1053	74	48	2.61	51	7.697
BPFA7454	854	967	1089	74	54	2.61	55	8.620
BPFA7460	892	1004	1127	74	60	2.61	60	9.544
BPFA8218	692	743	794	82	18	2.61	30	3.403
BPFA8224	729	790	859	82	24	2.61	35	4.424
BPFA8230	767	830	898	82	30	2.61	40	5.444
BPFA8236	805	930	1065	82	36	2.61	45	6.465
BPFA8242	842	968	1102	82	42	2.61	50	7.486
BPFA8248	884	1010	1143	82	48	2.61	55	8.507
BPFA8254	924	1052	1184	82	54	2.61	60	9.528
BPFA8260	964	1090	1224	82	60	2.61	65	10.549

**BPFG • Glazed Panel**

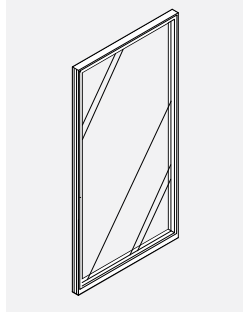

- Full-height glazing provides visual accessibility.
- Glazing is replaceable on site.

PRODUCT CODE	PRICE	SIZE/INCHES			WEIGHT VOL	
		H	W	D	LBS	FT <sup>3</sup>
BPFG5824	745	58	24	2.61	21	3.160
BPFG5830	817	58	30	2.61	24	3.889
BPFG5836	894	58	36	2.61	27	4.618
BPFG5842	965	58	42	2.61	30	5.347
BPFG5848	1037	58	48	2.61	33	6.076
BPFG6624	896	66	24	2.61	25	3.581
BPFG6630	971	66	30	2.61	28	4.407
BPFG6636	1049	66	36	2.61	31	5.234
BPFG6642	1127	66	42	2.61	34	6.060
BPFG6648	1203	66	48	2.61	37	6.887
BPFG7424	938	74	24	2.61	28	4.002
BPFG7430	1016	74	30	2.61	31	4.926
BPFG7436	1100	74	36	2.61	34	5.850
BPFG7442	1181	74	42	2.61	37	6.773
BPFG7448	1261	74	48	2.61	40	7.697
BPFG8224	1024	82	24	2.61	31	4.424
BPFG8230	1113	82	30	2.61	34	5.444
BPFG8236	1203	82	36	2.61	37	6.465
BPFG8242	1295	82	42	2.61	40	7.486
BPFG8248	1382	82	48	2.61	43	8.507



**BPOF • Fabric Over Panel**

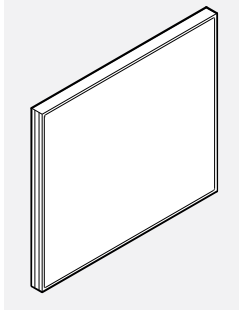

- Attaches to top of a panel to create floor-to-ceiling wall.
- Center septum overlaid on either side with 1 1/8" Mineral board.
- Non-slotted.
- Factory installed PVC strip attaches and aligns over panel to top of base panel.
- PVC strip runs entire width eliminating light seepage.
- For custom heights and widths, please order size required and price as next size up. Example: 26" high, 35" wide, order BPOF2635 at \$359 Grade 1.
- Custom heights over 42" must be quoted separately.
- Overpanels can be stacked on any panel. Example: BPOF2418 stacked on BPRA4218 to give an overall height of 66".
- When stacking on 29" or 37" high B1 panels, custom height required, please contact customer service.
- Exact height should be specified when ordering, with allowance of at least 1" of free space between over panel and ceiling to accommodate height variations in ceiling and floor. Runs of over panels should be captured at either end with full height posts, wall adapters, taller panels, and/or vertical trims.
- Minimum height of 6".
- OPT\* = Laminate or Whiteboard.

PRODUCT CODE	PRICE			SIZE/INCHES			WEIGHT VOL	
	GR 1	GR 2	OPT*	H	W	D	LBS	FT³
BPOF0818	163	174	191	8	18	2.61	6	0.351
BPOF0824	188	212	238	8	24	2.61	6	0.468
BPOF0830	222	249	275	8	30	2.61	8	0.730
BPOF0836	260	286	312	8	36	2.61	10	0.912
BPOF0842	287	312	339	8	42	2.61	10	0.912
BPOF0848	323	349	374	8	48	2.61	12	1.094
BPOF0854	361	384	411	8	54	2.61	12	1.094
BPOF0860	385	411	438	8	60	2.61	14	1.277
BPOF0866	525	579	636	8	66	2.61	17	1.549
BPOF0872	665	719	776	08	72	2.61	20	1.820
BPOF1618	215	227	244	16	18	2.61	8	0.730
BPOF1624	245	269	296	16	24	2.61	8	0.730
BPOF1630	280	304	331	16	30	2.61	10	0.912
BPOF1636	314	340	367	16	36	2.61	12	1.094
BPOF1642	341	367	394	16	42	2.61	12	1.094
BPOF1648	377	405	428	16	48	2.61	14	1.277
BPOF1654	414	438	466	16	54	2.61	14	1.277
BPOF1660	439	466	491	16	60	2.61	15	1.368
BPOF1666	595	648	705	16	66	2.61	20	1.774
BPOF1672	750	804	859	16	72	2.61	24	2.180
BPOF2418	295	306	322	24	18	2.61	12	1.094
BPOF2424	320	344	372	24	24	2.61	14	1.422
BPOF2430	345	372	398	24	30	2.61	17	1.750
BPOF2436	371	408	448	24	36	2.61	18	2.078
BPOF2442	395	433	475	24	42	2.61	21	2.406
BPOF2448	422	460	501	24	48	2.61	22	2.734
BPOF2454	444	471	496	24	54	2.61	24	3.063
BPOF2460	473	509	550	24	60	2.61	27	3.391
BPOF2466	635	687	744	24	66	2.61	32	3.766
BPOF2472	794	848	903	24	72	2.61	36	4.140
BPOF3718	338	363	389	37	18	2.61	17	1.580
BPOF3724	366	392	419	37	24	2.61	19	2.054
BPOF3730	393	431	473	37	30	2.61	22	2.528
BPOF3736	420	481	550	37	36	2.61	24	3.006
BPOF3742	444	508	576	37	42	2.61	28	3.476
BPOF3748	474	535	603	37	48	2.61	30	3.950
BPOF3754	498	562	631	37	54	2.61	32	4.424
BPOF3760	528	590	659	37	60	2.61	34	4.898
BPOF3766	744	849	962	37	66	2.61	41	5.449
BPOF3772	960	1065	-	37	72	2.61	48	6.000
BPOF4218	425	449	477	42	18	2.61	18	1.780
BPOF4224	452	504	557	42	24	2.61	21	2.310
BPOF4230	477	528	582	42	30	2.61	24	2.850
BPOF4236	506	567	637	42	36	2.61	27	3.390
BPOF4242	531	595	663	42	42	2.61	30	3.920
BPOF4248	561	624	697	42	48	2.61	33	4.460
BPOF4254	587	647	717	42	54	2.61	36	4.990
BPOF4260	616	678	745	42	60	2.61	39	5.250
BPOF4266	867	971	1085	42	66	2.61	47	6.015
BPOF4272	1118	1223	1337	42	72	2.61	54	6.780

**BPOG • Glazed Over Panel**

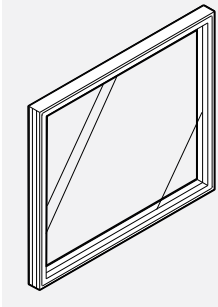

- Attaches to top of a panel to create floor-to-ceiling wall.
- Non-slotted.
- Factory installed PVC strip attaches and aligns over panel to top of base panel.
- PVC strip runs entire width eliminating light seepage.
- For custom heights and widths, order size required and price as next size up. Example: 26" high, 35" wide, order BPOG2635 at \$571 in acrylic.
- Custom heights over 42" must be quoted separately.
- Over panels can be stacked on any panel. Example: BPOG2418 stacked on BPRA4218 to give an overall height of 66".
- When stacking on 29" or 37" high B1 panels, custom height required, please contact customer service.
- Exact height should be specified when ordering, with allowance of at least 1" of free space between over panel and ceiling to accommodate height variations in ceiling and floor. Runs of over panels should be captured at either end with full height posts, wall adapters, taller panels, and/or vertical trims.
- Minimum height of 6".

PRODUCT CODE	PRICE	SIZE/INCHES			WEIGHT VOL	
		H	W	D	LBS	FT <sup>3</sup>
BPOG0818	108	8	18	2.61	6	0.351
BPOG0824	135	8	24	2.61	6	0.468
BPOG0830	163	8	30	2.61	8	0.730
BPOG0836	188	8	36	2.61	10	0.912
BPOG0842	215	8	42	2.61	10	0.912
BPOG0848	245	8	48	2.61	12	1.094
BPOG0854	271	8	54	2.61	12	1.094
BPOG0860	298	8	60	2.61	14	1.277
BPOG0866	394	8	66	2.61	17	1.549
BPOG0872	491	8	72	2.61	20	1.820
BPOG1618	172	16	18	2.61	8	0.730
BPOG1624	209	16	24	2.61	8	0.730
BPOG1630	245	16	30	2.61	10	0.912
BPOG1636	287	16	36	2.61	12	1.094
BPOG1642	314	16	42	2.61	12	1.094
BPOG1648	351	16	48	2.61	14	1.277
BPOG1654	385	16	54	2.61	14	1.277
BPOG1660	423	16	60	2.61	15	1.368
BPOG1666	550	16	66	2.61	20	1.774
BPOG1672	676	16	72	2.61	24	2.180
BPOG2418	309	24	18	2.61	12	1.094
BPOG2424	345	24	24	2.61	14	1.422
BPOG2430	383	24	30	2.61	17	1.750
BPOG2436	422	24	36	2.61	18	2.078
BPOG2442	460	24	42	2.61	21	2.406
BPOG2448	496	24	48	2.61	22	2.734
BPOG2454	534	24	54	2.61	24	3.063
BPOG2460	572	24	60	2.61	27	3.391
BPOG2466	786	24	66	2.61	32	3.766
BPOG2472	998	24	72	2.61	36	4.140
BPOG3718	439	37	18	2.61	17	1.580
BPOG3724	482	37	24	2.61	19	2.054
BPOG3730	528	37	30	2.61	22	2.528
BPOG3736	571	37	36	2.61	24	3.006
BPOG3742	616	37	42	2.61	28	3.476
BPOG3748	657	37	48	2.61	30	3.950
BPOG3754	698	37	54	2.61	32	4.424
BPOG3760	745	37	60	2.61	34	4.898
BPOG3766	968	37	66	2.61	41	5.449
BPOG3772	1192	37	72	2.61	48	6.000
BPOG4218	468	42	18	2.61	18	1.780
BPOG4224	513	42	24	2.61	21	2.310
BPOG4230	561	42	30	2.61	24	2.850
BPOG4236	604	42	36	2.61	27	3.390
BPOG4242	657	42	42	2.61	30	3.920
BPOG4248	698	42	48	2.61	33	4.460
BPOG4254	745	42	54	2.61	36	4.990
BPOG4260	789	42	60	2.61	39	5.250
BPOG4266	1035	42	66	2.61	47	6.015
BPOG4272	1278	42	72	2.61	54	6.780

**BAPAS • Glass Over Panel With Round Pucks for Boulevard 1**

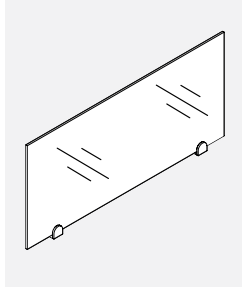

- Glass Over Panel creates division.
- Glass Over Panel with no frame sits on top of a Boulevard 1 Panel with clamps that are secured to the top of the panel.
- Tempered glass is 16" high.
- Custom sizes available, contact your Customer Service Representative.
- For application where the over panel is sandwiched between two taller panels, please request a special as the glass will not fit due to trims.

PRODUCT CODE	PRICE		SIZE/INCHES			WEIGHT VOL	
	CLR	FRST	H	W	D	LBS	FT <sup>3</sup>
BAPAS0824	212	241	8	24	1.3	4	0.22
BAPAS0830	231	259	8	30	1.3	5	0.30
BAPAS0836	249	279	8	36	1.3	6	0.37
BAPAS0842	263	299	8	42	1.3	7	0.43
BAPAS0848	271	317	8	48	1.3	8	0.48
BAPAS1624	212	234	16	24	1.3	8	0.44
BAPAS1630	231	259	16	30	1.3	10	0.59
BAPAS1636	249	279	16	36	1.3	12	0.73
BAPAS1642	263	299	16	42	1.3	14	0.85
BAPAS1648	271	317	16	48	1.3	16	0.96

**BAPASS • Glass Over Panel With Square Pucks for Boulevard 1**

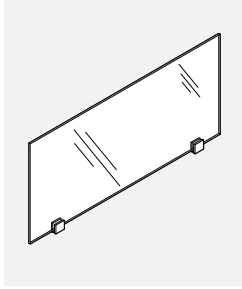

- Glass Over Panel creates division.
- Glass Over Panel with no frame sits on top of a Boulevard 1 Panel with clamps that are secured to the top of the panel.
- Tempered glass is 16" high.
- Custom sizes available, contact your Customer Service Representative.
- For application where the over panel is sandwiched between two taller panels, please request a special as the glass will not fit due to trims.

PRODUCT CODE	PRICE		SIZE/INCHES			WEIGHT VOL	
	CLR	FRST	H	W	D	LBS	FT <sup>3</sup>
BAPASS0824	216	238	8	24	1.3	4	0.22
BAPASS0830	237	263	8	30	1.3	5	0.30
BAPASS0836	253	284	8	36	1.3	6	0.37
BAPASS0842	268	304	8	42	1.3	7	0.43
BAPASS0848	277	320	8	48	1.3	8	0.48
BAPASS1624	216	238	16	24	1.3	8	0.44
BAPASS1630	237	263	16	30	1.3	10	0.59
BAPASS1636	253	284	16	36	1.3	12	0.73
BAPASS1642	268	304	16	42	1.3	14	0.85
BAPASS1648	277	320	16	48	1.3	16	0.96

**BAPAST • Felt Over Panel With Round Pucks for Boulevard 1**

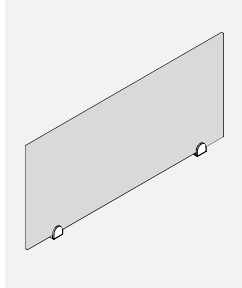

- Felt Over Panel creates division.
- Felt Over Panel with no frame sits on top of a Boulevard 1 panel with round clamps that are secured to the top of the panel.
- Felt panel is 8" and 16" high.
- 9 mm different colors. Please specify color.
- For application where the over panel is sandwiched between two taller panels, please request a special as the glass will not fit due to trims.

PRODUCT CODE	PRICE		SIZE/INCHES			WEIGHT VOL	
	CLR	FRST	H	W	D	LBS	FT <sup>3</sup>
BAPAST0824	137		8	22.7	1.13	1.0	0.11
BAPAST0830	149		8	28.7	1.13	1.1	0.14
BAPAST0836	160		8	34.7	1.13	1.2	0.17
BAPAST0842	173		8	40.7	1.13	1.3	0.20
BAPAST0848	187		8	46.7	1.13	1.4	0.23
BAPAST1624	177		16	22.7	1.13	1.4	0.23
BAPAST1630	200		16	28.7	1.13	1.5	0.29
BAPAST1636	228		16	34.7	1.13	1.7	0.35
BAPAST1642	249		16	40.7	1.13	1.9	0.42
BAPAST1648	265		16	46.7	1.13	2.0	0.48

**BAPASST • Felt Over Panel With Square Pucks for Boulevard 1**

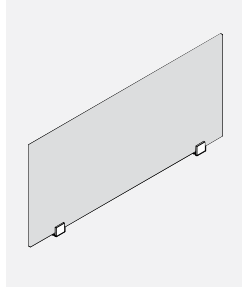

- Felt Over Panel creates division.
- Felt Over Panel with no frame sits on top of a Boulevard 1 panel with round clamps that are secured to the top of the panel.
- Felt panel is 8" and 16" high.
- 9 mm different colors. Please specify color.
- For application where the over panel is sandwiched between two taller panels, please request a special as the glass will not fit due to trims.

PRODUCT CODE	PRICE		SIZE/INCHES			WEIGHT VOL	
	CLR	FRST	H	W	D	LBS	FT <sup>3</sup>
BAPASST0824	137		8	22.7	1.13	1.0	0.11
BAPASST0830	149		8	28.7	1.13	1.1	0.14
BAPASST0836	160		8	34.7	1.13	1.2	0.17
BAPASST0842	173		8	40.7	1.13	1.3	0.20
BAPASST0848	187		8	46.7	1.13	1.4	0.23
BAPASST1624	177		16	22.7	1.13	1.4	0.23
BAPASST1630	200		16	28.7	1.13	1.5	0.29
BAPASST1636	228		16	34.7	1.13	1.7	0.35
BAPASST1642	249		16	40.7	1.13	1.9	0.42
BAPASST1648	265		16	46.7	1.13	2.0	0.48

**BPDS • Solid Door Panel**

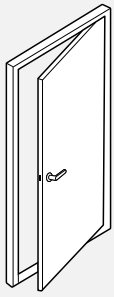

- Aluminum frame with high pressure laminate.
- 1 3/8" thick hollow core door.
- Actual door size:
  - 80" x 32 1/2" in 82" x 36" frame
  - 80" x 38 1/2" in 82" x 42" frame
- 42" wide Door Panel permits wheelchair accessibility.
- No hang-on capabilities.
- Non slotted frame.
- 180 degree swing.
- Specify Door Knob (DL01) or Door Lever (DL02).
- Lock standard.
- Handedness can be changed on site.
- Please specify Right hand (R) or Left hand (L) hung.

PRODUCT CODE	PRICE HP	SIZE/INCHES			WEIGHT VOL	
		H	W	D	LBS	FT <sup>3</sup>
BPDS8236R	2078	82	36	2.61	61	6.465
BPDS8242R	2263	82	42	2.61	68	7.486
BPDS8236L	2078	82	36	2.61	61	6.465
BPDS8242L	2263	82	42	2.61	68	7.486

**Door Hanging Directions**



Right Shown



Left Shown

**Door Handle Option**

Door Knob - DL01  
• Lock Standard



Door Lever - DL02(Default)  
Lock Standard

Lever complies with all accessibility standards



**BPDH • Half-Glazed Door Panel**

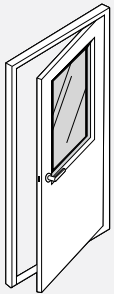

- Aluminum frame with high pressure laminate door and window.
- 1 3/8" thick hollow core door.
- Actual door size:
  - 80" x 32 1/2" in 82" x 36" frame
  - 80" x 38 1/2" in 82" x 42" frame
- 42" wide Door Panel permits wheelchair accessibility.
- No hang-on capabilities.
- 180 degree swing.
- Specify Door Knob (DL01) or Door Lever (DL02).
- Lock standard.
- Handedness can be changed on site.
- Please specify Right hand (R) or Left hand (L) hung.

PRODUCT CODE	PRICE HP	SIZE/INCHES			WEIGHT VOL	
		H	W	D	LBS	FT <sup>3</sup>
BPDH8236R	2573	82	36	2.61	53	6.465
BPDH8242R	2814	82	42	2.61	59	7.486
BPDH8236L	2573	82	36	2.61	53	6.465
BPDH8242L	2814	82	42	2.61	59	7.486

**Door Hanging Directions**



Right Shown



Left Shown

**Door Handle Option**

Door Knob - DL01  
• Lock Standard



Door Lever - DL02(Default)  
Lock Standard

Lever complies with all accessibility standards



**BPDG • Solid-Glazed Door Panel**

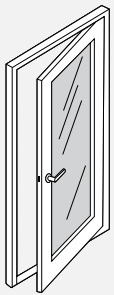

- Aluminum frame with either high pressure laminate door and window.
- 1 3/8" thick hollow core door.
- Actual door size:
  - 80" x 32 1/2" in 82" x 36" frame
  - 80" x 38 1/2" in 82" x 42" frame
- 42" wide Door Panel permits wheelchair accessibility.
- No hang-on capabilities.
- 180 degree swing.
- Specify Door Knob (DL01) or Door Lever (DL02).
- Lock standard.
- Handedness can be changed on site.
- Please specify Right hand (R) or Left hand (L) hung.
- Laminate frame is 5" thick on sides and 4" at top and bottom.

PRODUCT CODE	PRICE HP	SIZE/INCHES			WEIGHT VOL	
		H	W	D	LBS	FT <sup>3</sup>
BPDG8236R	4120	82	36	2.61	53	6.465
BPDG8242R	4507	82	42	2.61	59	7.486
BPDG8236L	4120	82	36	2.61	53	6.465
BPDG8242L	4507	82	42	2.61	59	7.486

**Door Hanging Directions**

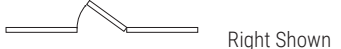

Right Shown



Left Shown

**Door Handle Option**

Door Knob - DL01  
• Lock Standard



Door Lever - DL02(Default)  
Lock Standard

Lever complies with all accessibility standards



**BPDSL • Privacy Screen**

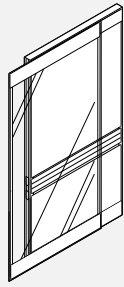

- Provides territorial privacy in an open plan environment.
  - Lightweight, panel-mounted sliding partition.
  - Consists of translucent textured polycarbonate.
  - Must be mounted to a straight panel of the same size.
  - The face of the Privacy Screen sits 3" away from the face of the panel to which it is attached.
  - Cable lay-in modules, wood trim and non-load bearing panels may be applied to the top of a panel to which the screen is attached, but not the screen itself.
  - When open, the screen may interfere with access doors that open on the outside of an adjacent panel.
  - Must specify left or right for the direction in which the door will slide once installed.
  - Caps located on the end of the frame default to the panel frame color.
  - All hardware included.
  - Can be mounted on Boulevard 1 or Boulevard System 3 panels of the same width as the Privacy Screen.
- Note: Specify left or right for the direction in which the door will slide as per examples above.

PRODUCT CODE	PRICE	SIZE/INCHES			WEIGHT VOL	
		H	W	D	LBS	FT <sup>3</sup>
BPDSL6636R	2074	66	36	2.61	35	5.98
BPDSL6642R	2234	66	42	2.61	42	6.93
BPDSL8136R	2489	81	36	2.61	43	7.30
BPDSL8142R	2672	81	42	2.61	50	8.45
BPDSL6636L	2074	66	36	2.61	35	5.98
BPDSL6642L	2234	66	42	2.61	42	6.93
BPDSL8136L	2489	81	36	2.61	43	7.30
BPDSL8142L	2672	81	42	2.61	50	8.45

Left Hang Option

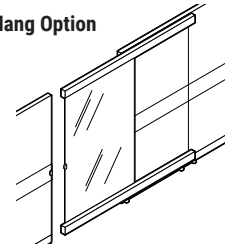

Right Hang Hung

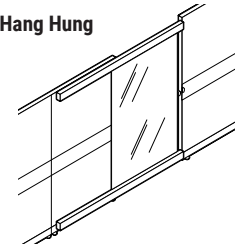

**BPDSLLOCK • Privacy Screen Lock**

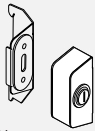

Left Hand Shown

- Lock bracket attaches to Privacy Screen with screws
- Includes strike plate bracket which attaches to slots in connector.
- Lock included.
- Available in tungsten only.
- Requires on site installation, drilling into the Privacy Screen aluminum frame.

PRODUCT CODE	PRICE	SIZE/INCHES			WEIGHT VOL	
		H	W	D	LBS	FT <sup>3</sup>
BPDSLLOCKR	320	2.65	1.2	0.9	1	0.2
BPDSLLOCKL	320	2.65	1.2	0.9	1	0.2

**BPXCF • Ceiling Filler**

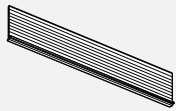

- Durable PVC designed to seal a gap between ceiling and over panel.
- Available in lengths of 124" to be pressed into over panel's horizontal wing profile.
- Can be applied during installation or retrofitted later.
- For use only with Boulevard 1 panels.

PRODUCT CODE	PRICE	SIZE/INCHES			WEIGHT VOL	
		H	W	D	LBS	FT <sup>3</sup>
BPXCF124	59	3.25	124	0.125	1	1.2

**BHP • 90 Degree Post**

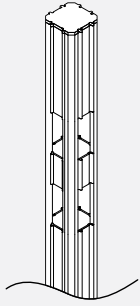

- Enables connection for multiple panel runs such as 90 degree, 3 way and 4 way.
- Includes 2 "Capture Strip" panel connectors, 4 end strips, 4 pairs of raceway end caps, and 1 post cap.
- Posts are designed to accept the following:
  - 75 cables 5.6 mm (0.220") diameter
  - 60 cables 5.6 mm (0.220") diameter with 1 powerfeed
  - 45 cables 5.6 mm (0.220") diameter with 2 powerfeeds

PRODUCT CODE	PRICE	SIZE/INCHES			WEIGHT VOL	
		H	W	D	LBS	FT <sup>3</sup>
BHP029	71	29	2.61	2.61	4	0.154
BHP037	112	37	2.61	2.61	5	0.195
BHP042	123	42	2.61	2.61	5	0.221
BHP050	139	50	2.61	2.61	6	0.263
BHP054	153	54	2.61	2.61	6	0.284
BHP058	153	58	2.61	2.61	7	0.305
BHP066	166	66	2.61	2.61	8	0.346
BHP074	179	74	2.61	2.61	9	0.388
BHP082	194	82	2.61	2.61	9	0.430
BHP106	230	106	2.61	2.61	12	0.560
BHP119	250	119	2.61	2.61	13	0.622

**BHP45 • 45 Degree Post**

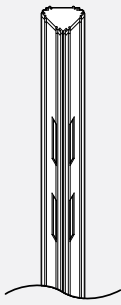

- Enables connection for two panels at 45 degrees.
- Includes 2 "Capture Strip" panel connectors, 4 end strips, 2 pairs of raceway end caps, and 1 post cap.
- 45 degree post does not accept PVC or Wood End Trim.
- No power infeed/post extension capabilities.
- Posts are designed to accept 30 cables 5.6 mm (0.220") diameter

PRODUCT CODE	PRICE	SIZE/INCHES			WEIGHT VOL	
		H	W	D	LBS	FT <sup>3</sup>
BHP4529	71	29	2.61	2.61	4	0.154
BHP4537	112	37	2.61	2.61	5	0.195
BHP4542	123	42	2.61	2.61	5	0.221
BHP4550	139	50	2.61	2.61	6	0.263
BHP4554	153	54	2.61	2.61	6	0.284
BHP4558	153	58	2.61	2.61	7	0.305
BHP4566	166	66	2.61	2.61	8	0.346
BHP4574	179	74	2.61	2.61	9	0.388
BHP4582	194	82	2.61	2.61	9	0.430
BHP45106	230	106	2.61	2.61	12	0.560
BHP45119	250	119	2.61	2.61	13	0.622

**BHP60 • 60 Degree Post**

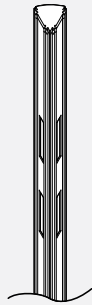

- Enables connection for multiple panel runs such as 120 degrees and 3 way.
- Includes 2 "Capture Strip" panel connectors, 4 end strips, 3 pair of raceway end caps, and 1 post cap.
- No power infeed/post extension capabilities.

PRODUCT CODE	PRICE	SIZE/INCHES			WEIGHT VOL	
		H	W	D	LBS	FT <sup>3</sup>
BHP6029	71	29	2.61	2.61	4	0.154
BHP6037	112	37	2.61	2.61	5	0.195
BHP6042	123	42	2.61	2.61	5	0.221
BHP6050	139	50	2.61	2.61	6	0.263
BHP6054	153	54	2.61	2.61	6	0.284
BHP6058	153	58	2.61	2.61	7	0.305
BHP6066	166	66	2.61	2.61	8	0.346
BHP6074	179	74	2.61	2.61	9	0.388
BHP6082	194	82	2.61	2.61	9	0.430
BHP60106	230	106	2.61	2.61	12	0.560
BHP60119	250	119	2.61	2.61	13	0.622

**BHWA • Wall Adapter**

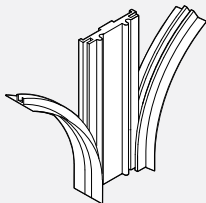

- Starts a run of panels off an existing wall.
- Includes 2 "Capture Strip" panel connectors and 1 pair of raceway end caps.
- Mounting hardware not included. The mounting hardware selected must be based on the wall or wall stud material.
- Wall adapter adds 5/16" to a panel run.

PRODUCT CODE	PRICE	SIZE/INCHES			WEIGHT VOL	
		H	W	D	LBS	FT <sup>3</sup>
BHWA029	47	29	2.61	0.375	4	0.01
BHWA037	49	37	2.61	0.375	5	0.013
BHWA042	56	42	2.61	0.375	5	0.015
BHWA050	64	50	2.61	0.375	6	0.018
BHWA054	68	54	2.61	0.375	6	0.020
BHWA058	69	58	2.61	0.375	7	0.021
BHWA066	72	66	2.61	0.375	8	0.024
BHWA074	76	74	2.61	0.375	9	0.027
BHWA082	82	82	2.61	0.375	9	0.030
BHWA106	99	106	2.61	0.375	12	0.039
BHWA119	108	119	2.61	0.375	13	0.043

**BHWASL • Adapter Sleeve**



- Wall Adapter Sleeve is attached to the building to provide flexible support to a panel run.
- As opposed to the BHWA wall adapter, which connects to the panels securely to a wall, B1 and B3 Boulevard panels rest inside the vertical "U" channel, providing up to 3.5" of flexible adjustment.
- For panel runs taller than 66" order two Wall Adapter Sleeve and either have them cut short on site below the ceiling, or cut a rectangular hole in the ceiling tile. Rectangular slots in the Channels correspond to 66", 58", 50" and 42" high B1 and B3 panels.
- Powder coated steel; specify metal finish.
- Note: the Wall Adapter Sleeve provides flexible, connection, blocks vertical 1" increment clots and cannot, therefore, be used to support overheads and worksurfaces, they must be supported by perpendicular panels, c-legs or gables.
- Note: No fasteners are provided with the Wall Adapter Sleeve. Select the appropriate fasteners according to a structurally wall type.
- Cannot be used to support a door or panel and cannot be used with laminate, airflow or metal skin panels.

PRODUCT CODE	PRICE	SIZE/INCHES			WEIGHT VOL	
		H	W	D	LBS	FT <sup>3</sup>
BHWASL42	201	34.7	4	2	2.5	0.161
BHWASL50	216	42.7	4	2	3.6	0.198
BHWASL54	223	42.7	4	2	4.2	0.220
BHWASL58	231	52.7	4	2	5.1	0.244
BHWASL66	249	58.7	4	2	6.0	0.272

**BHHF • High-Profile Foot**

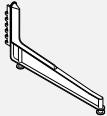

- Provides added support to panel under load.
- Adjustable glides included.
- Made of cast aluminum and cold rolled steel.
- Cannot be used with System 3 Panels

PRODUCT CODE	PRICE	SIZE/INCHES			WEIGHT VOL	
		H	W	D	LBS	FT <sup>3</sup>
BHHF01	314	9	1	18.375	4	0.130

**BHLF • Low-Profile Foot**

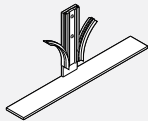

- Stabilizes a run of panels.
- Attaches with supplied connectors to an end of a panel.
- Made of cold rolled steel.
- Cannot be used with System 3 Panels

PRODUCT CODE	PRICE	SIZE/INCHES			WEIGHT VOL	
		H	W	D	LBS	FT <sup>3</sup>
BHLF01	43	6	9	2.5	7	0.230

**BHPA • Panel-to-Panel Adapter**

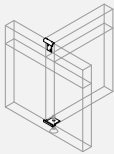

- Enables mid panel, off-module connection.
- Slim profile.
- Formed steel construction.
- Permanent clamps fit around base channel and fits to top rail.
- Priced as a complete kit.
- Designed for use with Boulevard 1 panels of the same height only.
- Not to be specified on panel seam or with over panels.
- Not to be used on the panel seam, with over panels or laminate and metal faced panels.

PRODUCT CODE	PRICE	SIZE/INCHES			WEIGHT VOL	
		H	W	D	LBS	FT <sup>3</sup>
BHPA02	43	2	2.5	00.0	0.25	0.120

**BHCS • Capture Strip Slot Cover**



- An extruded PVC channel to adjoin two panels or a panel to a post. Runs the full length of the panel on both sides providing a positive connection of the "Knuckle-Loc" design.
- Priced per pair.
- Pliable side membranes cover panel slots.
- Included with panel components.
- Only to be ordered separately if required.

PRODUCT CODE	PRICE	SIZE/INCHES			WEIGHT VOL	
		H			LBS	FT <sup>3</sup>
BHCS29	9	29			0.21	0.09
BHCS37	10	37			0.24	0.11
BHCS42	10	42			0.28	0.13
BHCS50	11	50			0.33	0.15
BHCS54	12	54			0.31	0.17
BHCS58	12	58			0.63	0.19
BHCS66	13	66			0.40	0.19
BHCS74	15	74			0.43	0.20
BHCS82	16	82			0.47	0.20

**BHCE • End Strip Slot Cover**

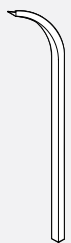

- End strips with pliable side membrane covers panel slots at end-of-run.
- Priced per pair.
- Included with panel components.
- Only to be ordered separately if required.

PRODUCT CODE	PRICE	SIZE/INCHES			WEIGHT VOL	
		H			LBS	FT <sup>3</sup>
BHCE29	6	29			0.10	0.04
BHCE37	7	37			0.12	0.05
BHCE42	7	42			0.14	0.06
BHCE50	9	50			0.16	0.07
BHCE54	9	54			0.31	0.08
BHCE58	9	58			0.18	0.08
BHCE66	10	66			0.20	0.09
BHCE74	10	74			0.22	0.10
BHCE82	12	82			0.23	0.11

**BHRC • Raceway End Cap**

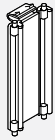

- Provides clean detail at the end of a panel run or post. End caps fit flush into communication and power channel entry.
- Priced per pair.
- Made of injection molded ABS.
- Included with panel components. Only to be ordered separately if required.

PRODUCT CODE	PRICE	SIZE/INCHES			WEIGHT VOL	
		H	W	D	LBS	FT <sup>3</sup>
BHRC02	6	3	2.61	0.5	0.04	0.02

**BVTE • Vertical End PVC Trim**

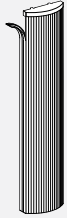

- Provides a rounded finished detail to the end of the panel run, or a post.
- Includes 2 "Capture Strip" panel connectors and 1 injection molded top cap.
- The PVC end trim is designed to snap at the end of the panel or post.
- Site installed.

PRODUCT CODE	PRICE	SIZE/INCHES			WEIGHT VOL	
		H	W	D	LBS	FT <sup>3</sup>
BVTE37	28	37	2.61	0.25	0.41	0.065
BVTE42	31	42	2.61	0.25	0.48	0.074
BVTE50	34	50	2.61	0.25	0.57	0.088
BVTE54	36	54	2.61	0.25	0.62	0.095
BVTE58	38	58	2.61	0.25	0.66	0.102
BVTE66	42	66	2.61	0.25	0.75	0.115
BVTE74	47	74	2.61	0.25	0.84	0.013
BVTE82	55	82	2.61	0.25	0.93	0.143

**BVTS • Vertical Step Down PVC Trim**

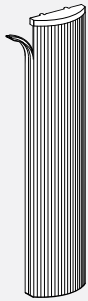

- Provides a rounded finished detail to the end of the panel run where two different height panels are specified.
- Includes 2 "Capture Strip" panel connectors and 1 injection molded top cap.
- The PVC end trim is designed to snap at the end of the panel or post.
- Site installed.
- Please specify panels to be used when ordering a 29" step (BVTS29).

PRODUCT CODE	PRICE	SIZE/INCHES			WEIGHT VOL	
		H	W	D	LBS	FT <sup>3</sup>
BVTS04	10	4	2.61	0.25	0.05	0.010
BVTS08	12	8	2.61	0.25	0.09	0.015
BVTS12	14	12	2.61	0.25	0.12	0.021
BVTS16	26	16	2.61	0.25	0.18	0.029
BVTS20	27	20	2.61	0.25	0.20	0.035
BVTS24	28	24	2.61	0.25	0.27	0.043
BVTS32	31	32	2.61	0.25	0.36	0.056
BVTS38	32	38	2.61	0.25	0.45	0.067
BVTS40	31	40	2.61	0.25	0.45	0.070
BVTS48	32	48	2.61	0.25	0.54	0.084
BVTS56	34	56	2.61	0.25	0.63	0.098

**BVTS • Vertical Step Down PVC Trim for 37"-High Panels**

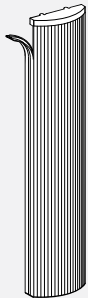

- Provides a finished detail to the end of the panel run that sits next to a 37" high panel. This PVC trim will bridge the distance between the 37" and higher panel.
- Includes 2 "Capture Strip" panel connectors and 1 injection molded top cap.
- The PVC end trim is designed to snap at the end of the panel or post.
- Site installed.
- Please specify panels to be used when ordering a 29" step (BVTS29).

PRODUCT CODE	PRICE	SIZE/INCHES			WEIGHT VOL	
		H	W	D	LBS	FT <sup>3</sup>
BVTS05	10	5	2.61	0.25	0.06	0.015
BVTS13	14	13	2.61	0.25	0.15	0.029
BVTS17	27	17	2.61	0.25	0.15	0.035
BVTS21	28	21	2.61	0.25	0.24	0.043
BVTS29	29	29	2.61	0.25	0.33	0.051
BVTS37	31	37	2.61	0.25	0.41	0.067
BVTS45	32	45	2.61	0.25	0.51	0.084

**BAVTE • Aluminum Vertical End Round Trim**

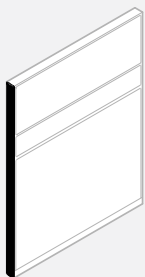

- Provides a finished detail to the end of a panel run.
- Aluminum radiused front section and injection molded top cap.
- Includes 2 "Capture Strip" panel connectors and 1 injection molded top cap.
- The Aluminum End Trim is designed to snap at the end of the panel or post.
- Site installed.
- BAVTE119 cannot ship via courier and must be combined with other product.

PRODUCT CODE	PRICE	SIZE/INCHES			WEIGHT VOL	
		H	W	D	LBS	FT <sup>3</sup>
BAVTE37	75	37	2.61	0.125	1.2	0.03
BAVTE42	85	42	2.61	0.125	1.4	0.03
BAVTE50	99	50	2.61	0.125	1.7	0.04
BAVTE54	108	54	2.61	0.125	1.8	0.04
BAVTE58	115	58	2.61	0.125	1.9	0.04
BAVTE66	131	66	2.61	0.125	2.2	0.05
BAVTE74	155	74	2.61	0.125	2.4	0.05
BAVTE82	163	82	2.61	0.125	2.7	0.06
BAVTE119	236	119	2.61	0.125	3.9	0.08



**BAVTS • Aluminum Vertical End Round Trim - Standard Step Down**

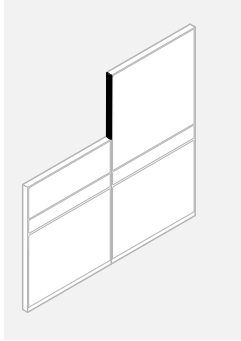

- Provides a finished detail to the end of a panel run where two different height panels are specified.
- Aluminum radiused front section and injection molded top cap.
- Includes 2 "Capture Strip" panel connectors and 1 injection molded top cap.
- The Aluminum End Trim is designed to snap at the end of the panel or post.
- Site installed.
- Specify panels to be used when ordering a 29" step.

PRODUCT CODE	PRICE	SIZE/INCHES			WEIGHT VOL	
		H	W	D	LBS	FT <sup>3</sup>
BAVTS04	21	4	2.61	0.125	0.2	0.01
BAVTS08	26	8	2.61	0.125	0.3	0.02
BAVTS12	39	12	2.61	0.125	0.4	0.02
BAVTS16	39	16	2.61	0.125	0.5	0.03
BAVTS20	39	20	2.61	0.125	0.7	0.04
BAVTS24	59	24	2.61	0.125	0.8	0.04
BAVTS32	75	32	2.61	0.125	1.1	0.06
BAVTS38	88	38	2.61	0.125	1.3	0.07
BAVTS40	93	40	2.61	0.125	1.3	0.07
BAVTS48	112	48	2.61	0.125	1.6	0.08
BAVTS56	126	56	2.61	0.125	1.8	0.10

**BAVTSF • Aluminum Vertical End Round Trim - Step Down for 37"-High Panels**

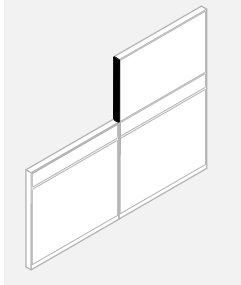

- Provides a finished detail to the end of a panel run adjacent to a 37" high panel.
- Aluminum radiused front section and injection molded top cap.
- Includes 2 "Capture Strip" panel connectors and 1 injection molded top cap.
- The Aluminum End Trim is designed to snap at the end of the panel or post.
- Site installed.

PRODUCT CODE	PRICE	SIZE/INCHES			WEIGHT VOL	
		H	W	D	LBS	FT <sup>3</sup>
BAVTSF05	26	5	2.61	0.125	0.2	0.02
BAVTSF13	39	13	2.61	0.125	0.4	0.03
BAVTSF17	39	17	2.61	0.125	0.6	0.04
BAVTSF21	59	21	2.61	0.125	0.7	0.04
BAVTSF29	75	29	2.61	0.125	1.0	0.05
BAVTSF37	88	37	2.61	0.125	1.2	0.07
BAVTSF45	112	45	2.61	0.125	1.5	0.08

**BARC • Aluminum Raceway Cover**

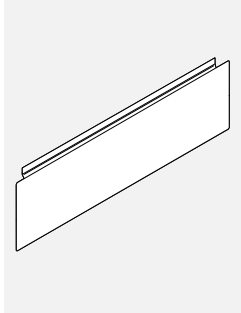

- Offers an alternative to the existing raceway options.
- Cover hinges upward for easy access to power and data/communication terminals.
- Cover may be removed for installation and reconfiguration.
- May not be used with Boulevard System 3 panels.
- Sold as singles.

PRODUCT CODE	PRICE	SIZE/INCHES	INCHES		WEIGHT VOL	
			H	W	D	LBS
BARC06	32	00.0	5	0.125	0.3	0.001
BARC18	36	00.0	17	0.125	1.1	0.001
BARC24	42	00.0	23	0.125	1.4	0.001
BARC30	45	00.0	29	0.125	1.8	0.002
BARC36	49	00.0	35	0.125	2.2	0.002
BARC42	53	00.0	41	0.125	2.5	0.002
BARC48	56	00.0	47	0.125	2.9	0.003
BARC54	64	00.0	53	0.125	3.2	0.003
BARC60	74	00.0	59	0.125	3.7	0.003
BARC66	82	00.0	65	0.125	4.1	0.004
BARC72	86	00.0	72	0.125	4.4	0.004

**Boulevard 1 • Flat Aluminum Trims**

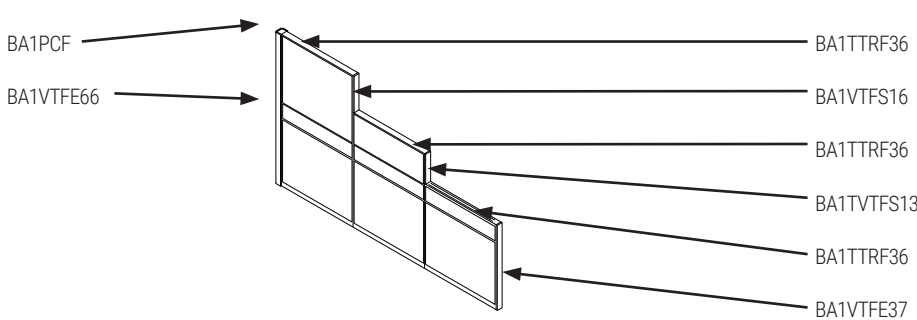

**Flat Aluminum Trims For Boulevard 1:**  
 Designed to use top and vertical trims together on the panel. Specifying vertical trims only will make them too long and will not fit correctly.  
 You must specify vertical trims as a special if you are NOT using top trims.  
 Post caps BA1PCF must be specified separately when using trims, .

**BA1VTFE • Aluminum Vertical Flat End Trim**

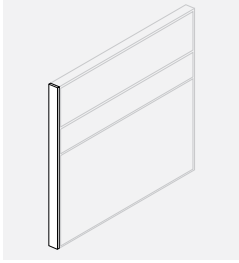

- Provides a finish detail to the end of a panel run.
- Aluminum flat profile with injection molded top cap.
- Included: 2 "capture strip" panel connectors and 1 injection molded top cap.
- The Aluminum End Trim is designed to snap at the end of the panel or post.
- Site installed.
- For use with Aluminum Top Caps.

PRODUCT CODE	PRICE	SIZE/INCHES			WEIGHT VOL	
		H	W	D	LBS	FT <sup>3</sup>
BA1VTFE29	33	29	2.61	0.125	0.7	0.01
BA1VTFE37	53	37	2.61	0.125	1.0	0.02
BA1VTFE42	59	42	2.61	0.125	1.2	0.03
BA1VTFE50	70	50	2.61	0.125	1.5	0.04
BA1VTFE54	76	54	2.61	0.125	1.6	0.04
BA1VTFE58	81	58	2.61	0.125	1.7	0.04
BA1VTFE66	92	66	2.61	0.125	2.0	0.05
BA1VTFE74	103	74	2.61	0.125	2.2	0.05
BA1VTFE82	115	82	2.61	0.125	2.4	0.06

**BA1VTFS • Aluminum Vertical Flat End Trim - Standard Step Down**

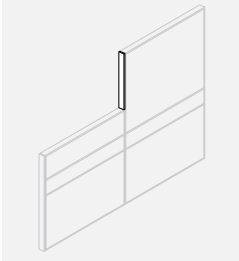

- Provides a finish detail to the end of a panel run where 2 different height panels are specified.
- Aluminum flat profile with injection molded top cap.
- Included: 2 "capture strip" panel connectors and 1 injection molded top cap.
- The aluminum end trim is designed to snap at the end of the panel or post.
- Site installed.
- For use with Aluminum Top Caps.

PRODUCT CODE	PRICE	SIZE/INCHES			WEIGHT VOL	
		H	W	D	LBS	FT <sup>3</sup>
BA1VTFS04	10	4	2.61	0.125	0.1	0.01
BA1VTFS08	16	8	2.61	0.125	0.2	0.01
BA1VTFS12	25	12	2.61	0.125	0.4	0.02
BA1VTFS16	31	16	2.61	0.125	0.6	0.02
BA1VTFS20	39	20	2.61	0.125	0.6	0.03
BA1VTFS24	42	24	2.61	0.125	0.7	0.03
BA1VTFS32	50	32	2.61	0.125	0.9	0.03
BA1VTFS38	56	38	2.61	0.125	1.1	0.03
BA1VTFS40	59	40	2.61	0.125	1.1	0.03
BA1VTFS48	66	48	2.61	0.125	1.3	0.04
BA1VTFS56	76	56	2.61	0.125	1.6	0.05

**BA1VTFS • Aluminum Vertical Flat End Trim - Standard Step Down 37"-High Panels**

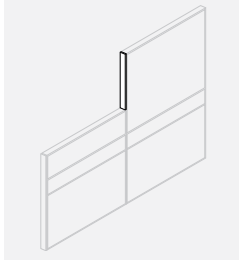

- Provides a finish detail to the end of a panel run adjacent to a 37" high panel.
- Aluminum flat profile with injection molded top cap
- Included 2 "capture strip" panel connectors and 1 injection molded top cap
- The aluminum end trim is designed to snap at the end of the panel or post
- Site installed
- Specify panels to be used when ordering a 29" step down trim.
- For use with Aluminum Top Caps.

PRODUCT CODE	PRICE	SIZE/INCHES			WEIGHT VOL	
		H	W	D	LBS	FT <sup>3</sup>
BA1VTFS05	15	5	2.61	0.125	0.2	0.01
BA1VTFS13	26	13	2.61	0.125	0.4	0.01
BA1VTFS17	36	17	2.61	0.125	0.4	0.01
BA1VTFS21	39	21	2.61	0.125	0.6	0.02
BA1VTFS29	45	19	2.61	0.125	0.7	0.03
BA1VTFS37	54	37	2.61	0.125	1.1	0.03
BA1VTFS45	64	45	2.61	0.125	1.3	0.04

**BA1TTRF • Aluminum Top Cap**

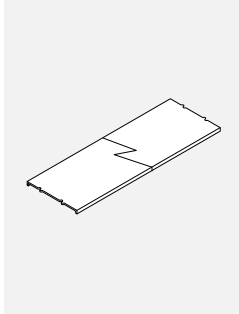

- Provides a finish detail to the top of a Boulevard 1 panel.
- Designed to snap to the top of a panel rail.
- Must be used on panels of corresponding width.
- Site installed.
- For applications using transaction tops and top mounted storage, please use BHBT02FT bracket
- To be used with Flat Vertical Trim.

PRODUCT CODE	PRICE	SIZE/INCHES			WEIGHT VOL	
		H	W	D	LBS	FT <sup>3</sup>
BA1TTRF06	15	0.125	6	2.61	0.2	0.01
BA1TTRF18	16	0.125	18	2.61	0.6	0.02
BA1TTRF24	20	0.125	24	2.61	0.7	0.03
BA1TTRF30	23	0.125	30	2.61	0.9	0.04
BA1TTRF36	28	0.125	36	2.61	1.1	0.05
BA1TTRF42	34	0.125	42	2.61	1.3	0.06
BA1TTRF48	39	0.125	48	2.61	1.5	0.06
BA1TTRF54	45	0.125	54	2.61	1.6	0.07
BA1TTRF60	50	0.125	60	2.61	1.8	0.08
BA1TTRF66	55	0.125	66	2.61	2.0	0.09
BA1TTRF72	58	0.125	72	2.61	2.2	0.10

**BA1PCF • Post Cap**

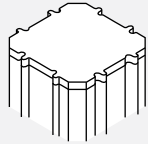

- Bridges the height difference when using Boulevard 1 panels only with Aluminum Horizontal Top Trims.
- Injection molded post cap to fit on top of 90 degree corner post.
- Extends post's overall height to the level corresponding with the height of aluminum horizontal top trim installed on standard Boulevard panel.
- Site installed.
- Used for Boulevard 1 panels when top aluminum horizontal trim is used.

PRODUCT CODE	PRICE	SIZE/INCHES			WEIGHT VOL	
		H	W	D	LBS	FT <sup>3</sup>
BA1PCF	10	0.25	2.61	2.61	0.02	0.01

**BHBT37FT • Transaction Bracket for 37" Panels With Flat Trim**



- Provides a secure attachment of a transaction worksurface for a 37" high panel with top trim.
- Includes a left and right bracket and bracket retainer clips.

PRODUCT CODE	PRICE	SIZE/INCHES			WEIGHT VOL	
		H	W	D	LBS	FT <sup>3</sup>
BHBT37FT	32	3.3	1.5	2.3	2.0	0.010

**BHBT02FT • Transaction Bracket for 42" Panels With Flat Trim**

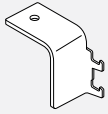

- Provides a secure attachment of a transaction worksurface for 42" high Boulevard panels with flat trim.
- Includes a left and right bracket and bracket retainer clips.

PRODUCT CODE	PRICE	SIZE/INCHES			WEIGHT VOL	
		H	W	D	LBS	FT <sup>3</sup>
BHBT02FT	31	4	1	3	0.5	0.007

**FRC • Fabric Raceway Cover**

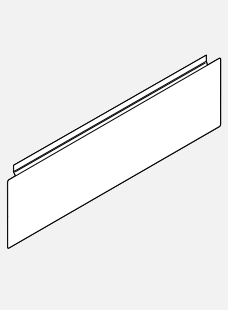

- Offers an alternative to the existing raceway options.
- Cover hinges upward for easy access to power and data/communication terminals.
- Cover may be removed for installation and reconfiguration.
- May not be used with Boulevard System 3 panels.
- Sold as singles.

PRODUCT CODE	PRICE	SIZE/INCHES			WEIGHT VOL	
		H	W	D	LBS	FT <sup>3</sup>
FRC24	38	7	23	0.125	1.4	0.001
FRC30	45	7	29	0.125	1.8	0.002
FRC36	50	7	35	0.125	2.2	0.002
FRC42	54	7	41	0.125	2.5	0.002
FRC48	59	7	47	0.125	2.9	0.003
FRC54	66	7	53	0.125	3.2	0.003
FRC60	74	7	59	0.125	3.7	0.003
FRC66	79	7	65	0.125	4.1	0.004
FRC72	81	7	72	0.125	4.4	0.004

**RCW-D • PVC Face-Mount Raceway Cover**

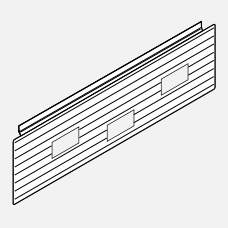

- PVC raceway cover is punched out to align with the Face-Mount Power Distribution Housing and Duplexes.
- Data punch-out accepts industry standard terminal faceplates (not supplied by Teknion Inc.) Size of opening is 1.37" x 2.755".
- Electrical cut-outs have black PVC trim. Size of opening is 1.5" x 2.85".
- May not be used with Boulevard System 3 Panels.
- Cover hinges upward for easy access to power and data/communication terminals.

PRODUCT CODE	PRICE	SIZE/INCHES			WEIGHT VOL	
		H	W	D	LBS	FT <sup>3</sup>
RCW24D	33	7	24	0.125	3	0.05
RCW30D	36	7	30	0.125	3	0.06
RCW36D	39	7	36	0.125	4	0.07
RCW42D	45	7	42	0.125	5	0.08
RCW48D	49	7	48	0.125	5	0.09
RCW54D	52	7	54	0.125	6	0.10
RCW60D	55	7	60	0.125	7	0.11
RCW66D	59	7	66	0.125	7	0.12
RCW72D	64	7	72	0.125	8	0.12

**FCR-D • Fabric-Covered Face-Mount Raceway**

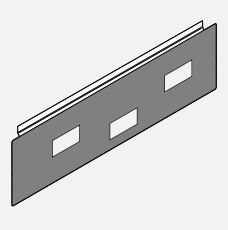

- Fabric raceway cover is punched out to align with the Face-Mount Power Distribution Housing and Duplexes.
- Data punch-out accepts industry standard terminal faceplates (not supplied by Teknion Inc.) Size of opening is 1.37" x 2.755".
- Electrical cut-outs have black PVC trim. Size of opening is 1.5" x 2.85".
- May not be used with Boulevard System 3 Panels.
- Cover hinges upward for easy access to power and data/communication terminals.

PRODUCT CODE	PRICE	SIZE/INCHES			WEIGHT VOL	
		H	W	D	LBS	FT <sup>3</sup>
FCR24D	83	7	24	0.125	3	0.05
FCR30D	92	7	30	0.125	3	0.06
FCR36D	101	7	36	0.125	4	0.07
FCR42D	109	7	42	0.125	5	0.08
FCR48D	118	7	48	0.125	5	0.09
FCR54D	126	7	54	0.125	6	0.10
FCR60D	135	7	60	0.125	7	0.11
FCR66D	144	7	66	0.125	7	0.12
FCR72D	164	7	72	0.125	8	0.12

**RCA-D • Aluminum Raceway Cover for Face Mounted**

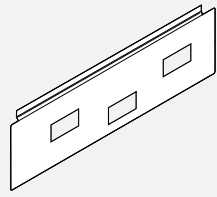

- Aluminum raceway cover is punched out to align with the Face-Mount Power Distribution Housing and Duplexes.
- Data punch-out accepts industry standard terminal faceplates (not supplied by Teknion Inc.) Size of opening is 1.37" x 2.755".
- Electrical cut-outs have black PVC trim. Size of opening is 1.5" x 2.85".
- May not be used with Boulevard System 3 Panels.
- Cover hinges upward for easy access to power and data/communication terminals.

PRODUCT CODE	PRICE	SIZE/INCHES			WEIGHT VOL	
		H	W	D	LBS	FT <sup>3</sup>
RCA24D	54	7	24	0.125	2.0	0.06
RCA30D	58	7	30	0.125	2.1	0.06
RCA36D	64	7	36	0.125	2.2	0.07
RCA42D	69	7	42	0.125	2.5	0.08
RCA48D	71	7	48	0.125	2.9	0.09
RCA54D	76	7	54	0.125	3.2	0.10
RCA60D	81	7	60	0.125	3.7	0.11
RCA66D	86	7	66	0.125	3.9	0.12
RCA72D	90	7	72	0.125	4.1	0.12

**RCW-SCH • Chicago Face-Mount Raceway Cover - Single Cutout**

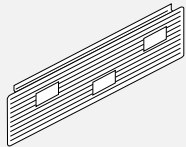

- PVC raceway cover is punched out to align with the Face-Mount Power Distribution Housing and Duplexes.
- Raceway has a single punch out
- Data punchout accepts industry standard terminal faceplates (not supplied by Teknion Inc.) Size of opening is 1.37" x 2.755".
- Electrical cutouts have black PVC trim. Size of opening is 1.5" x 2.85".
- May not be used with Boulevard System 3 Panels.
- Cover hinges upward for easy access to power and data/communication terminals.

PRODUCT CODE	PRICE	SIZE/INCHES			WEIGHT VOL	
		H	W	D	LBS	FT <sup>3</sup>
RCW24SCH	36	7	24	0.13	3.0	0.050
RCW30SCH	38	7	30	0.13	3.0	0.060
RCW36SCH	42	7	36	0.13	4.0	0.070
RCW42SCH	49	7	42	0.13	5.0	0.080
RCW48SCH	53	7	48	0.13	5.0	0.090
RCW54SCH	55	7	54	0.13	6.0	0.100
RCW60SCH	59	7	60	0.13	7.0	0.110
RCW66SCH	65	7	66	0.13	7.0	0.120
RCW72SCH	69	7	72	0.13	8.0	0.120

**FCR-SCH • Chicago Fabric-Covered Face-Mount Raceway Cover - Single Cutout**

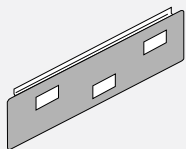

- Fabric raceway cover is punched out to align with the Face-Mount Power Distribution Housing and Duplexes.
- Raceway has a single punch out
- Data punchout accepts industry standard terminal faceplates (not supplied by Teknion Inc.) Size of opening is 1.37" x 2.755".
- Electrical cutouts have black PVC trim. Size of opening is 1.5" x 2.85".
- May not be used with Boulevard System 3 Panels.
- Cover hinges upward for easy access to power and data/communication terminals.

PRODUCT CODE	PRICE	SIZE/INCHES			WEIGHT VOL	
		H	W	D	LBS	FT <sup>3</sup>
FCR24SCH	83	7	24	0.13	3.0	0.050
FCR30SCH	92	7	30	0.13	3.0	0.060
FCR36SCH	101	7	36	0.13	4.0	0.070
FCR42SCH	109	7	42	0.13	5.0	0.080
FCR48SCH	118	7	48	0.13	5.0	0.090
FCR54SCH	126	7	54	0.13	6.0	0.100
FCR60SCH	135	7	60	0.13	7.0	0.110
FCR66SCH	144	7	66	0.13	7.0	0.120
FCR72SCH	164	7	72	0.13	8.0	0.120

**RCA-SCH • Chicago Aluminum Face-Mount Raceway Cover - Single Cutout**

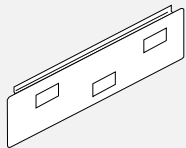

- Aluminum raceway cover is punched out to align with the Face-Mount Power Distribution Housing and Duplexes.
- Raceway has a single punch out
- Data punchout accepts industry standard terminal faceplates (not supplied by Teknion Inc.) Size of opening is 1.37" x 2.755".
- Electrical cutouts have black PVC trim. Size of opening is 1.5" x 2.85".
- May not be used with Boulevard System 3 Panels.
- Cover hinges upward for easy access to power and data/communication terminals.

PRODUCT CODE	PRICE	SIZE/INCHES			WEIGHT VOL	
		H	W	D	LBS	FT <sup>3</sup>
RCA24SCH	58	7	24	0.13	2.0	0.060
RCA30SCH	64	7	30	0.13	2.1	0.060
RCA36SCH	69	7	36	0.13	2.2	0.070
RCA42SCH	72	7	42	0.13	2.5	0.080
RCA48SCH	75	7	48	0.13	2.9	0.090
RCA54SCH	81	7	54	0.13	3.2	0.100
RCA60SCH	86	7	60	0.13	3.7	0.110
RCA66SCH	92	7	66	0.13	3.9	0.120
RCA72SCH	96	7	72	0.13	4.1	0.120

**RCW-DCH • Chicago Face-Mount Raceway Cover - Double Cutout**

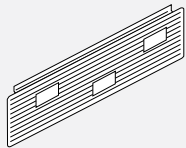

- PVC raceway cover is punched out to align with the Face-Mount Power Distribution Housing and Duplexes.
- Raceway has a double punch out
- Data punchout accepts industry standard terminal faceplates (not supplied by Teknion Inc.) Size of opening is 1.37" x 2.755".
- Electrical cutouts have black PVC trim. Size of opening is 1.5" x 2.85".
- May not be used with Boulevard System 3 Panels.
- Cover hinges upward for easy access to power and data/communication terminals.

PRODUCT CODE	PRICE	SIZE/INCHES			WEIGHT VOL	
		H	W	D	LBS	FT <sup>3</sup>
RCW24DCH	38	7	24	0.13	3.0	0.050
RCW30DCH	41	7	30	0.13	3.0	0.060
RCW36DCH	45	7	36	0.13	4.0	0.070
RCW42DCH	53	7	42	0.13	5.0	0.080
RCW48DCH	58	7	48	0.13	5.0	0.090
RCW54DCH	60	7	54	0.13	6.0	0.100
RCW60DCH	66	7	60	0.13	7.0	0.110
RCW66DCH	70	7	66	0.13	7.0	0.120
RCW72DCH	75	7	72	0.13	8.0	0.120

**FCR-DCH • Chicago Fabric-Covered Face-Mount Raceway Cover - Double Cutout**

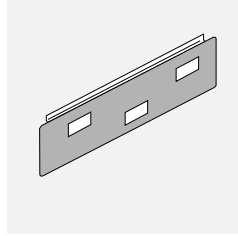

- Fabric raceway cover is punched out to align with the Face-Mount Power Distribution Housing and Duplexes.
- Raceway has a single punch out
- Data punchout accepts industry standard terminal faceplates (not supplied by Teknion Inc.) Size of opening is 1.37" x 2.755".
- Electrical cutouts have black PVC trim. Size of opening is 1.5" x 2.85".
- May not be used with Boulevard System 3 Panels.
- Cover hinges upward for easy access to power and data/communication terminals.

PRODUCT CODE	PRICE	SIZE/INCHES			WEIGHT VOL	
		H	W	D	LBS	FT <sup>3</sup>
FCR24DCH	83	7	24	0.13	3.0	0.050
FCR30DCH	92	7	30	0.13	3.0	0.060
FCR36DCH	101	7	36	0.13	4.0	0.070
FCR42DCH	109	7	42	0.13	5.0	0.080
FCR48DCH	118	7	48	0.13	5.0	0.090
FCR54DCH	126	7	54	0.13	6.0	0.100
FCR60DCH	135	7	60	0.13	7.0	0.110
FCR66DCH	144	7	66	0.13	7.0	0.120
FCR72DCH	164	7	72	0.13	8.0	0.120

**RCA-DCH • Chicago Aluminum Face-Mount Raceway Cover - Double Cutout**

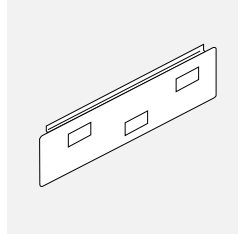

- Aluminum raceway cover is punched out to align with the Face-Mount Power Distribution Housing and Duplexes.
- Raceway has a single punch out
- Data punchout accepts industry standard terminal faceplates (not supplied by Teknion Inc.) Size of opening is 1.37" x 2.755".
- Electrical cutouts have black PVC trim. Size of opening is 1.5" x 2.85".
- May not be used with Boulevard System 3 Panels.
- Cover hinges upward for easy access to power and data/communication terminals.

PRODUCT CODE	PRICE	SIZE/INCHES			WEIGHT VOL	
		H	W	D	LBS	FT <sup>3</sup>
RCA24DCH	64	7	24	0.13	2.0	0.060
RCA30DCH	69	7	30	0.13	2.1	0.060
RCA36DCH	75	7	36	0.13	2.2	0.070
RCA42DCH	79	7	42	0.13	2.5	0.080
RCA48DCH	82	7	48	0.13	2.9	0.090
RCA54DCH	88	7	54	0.13	3.2	0.100
RCA60DCH	93	7	60	0.13	3.7	0.110
RCA66DCH	99	7	66	0.13	3.9	0.120
RCA72DCH	104	7	72	0.13	4.1	0.120

**BPMB • Raceway Cover Caps**

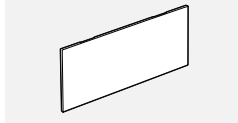

- To provide clean detail for the punch-outs of a raceway cover when the punch-outs are not in use. Order only when required.
- Made of injection molded ABS.
- B = Black
- W = White
- G =Grey

PRODUCT CODE	PRICE	SIZE/INCHES			WEIGHT VOL	
		H	W	D	LBS	FT <sup>3</sup>
BPMB020104B	10	1.5	3	0.125	0.04	0.02
BPMB020104G	10	1.5	3	0.125	0.04	0.02
BPMB020104W	10	1.5	3	0.125	0.04	0.02

**BHSL • Safety Lock**

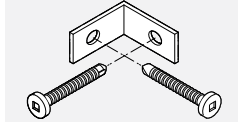

- Provides customers a higher degree of privacy.
- Safety Lock is a set of two ready made brackets and
- It is installed from the inside of a panel adjacent to a opening the door through the raceway.
- To be used for PVC raceways only.

PRODUCT CODE	PRICE
BHSL02	31

**BHV • Component Wall Adapter - Single and Double**

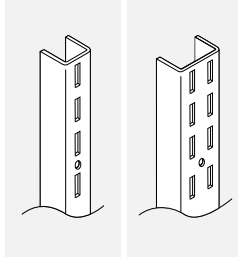

- Used to attach system components to fixed wall.
- Panel frame finish.
- The vertical wall adapter is a "U" shaped channel with a vertical row of slots with 1" centers.
- The double Component Wall Adapter has a double row of slots with 1" centers.
- Comes in 60" length only.
- Care should be taken to mount adapters only to wall studs using correct fasteners.
- Does not include mounting hardware. Mounting hardware selection to be based on wall material.
- Sold in pairs.
- Failure to do this may result in collapse of the unit and subsequent possible personal injury.

PRODUCT CODE	PRICE	SIZE/INCHES			WEIGHT VOL	
		H	W	D	LBS	FT <sup>3</sup>
BHV01	77	60	0.75	0.5	4	0.009
BHV02	91	60	1.50	0.5	5	0.026

**BECC01 • Cable Terminal Channel**

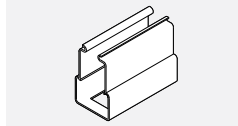

- Houses various combinations of voice and data cables.
- 1 included with every Raceway Panel.
- Accommodates assorted snap-in modular voice and data terminals (not supplied by Teknion Inc).
- Black only.

PRODUCT CODE	PRICE	SIZE/INCHES			WEIGHT VOL	
		H	W	D	LBS	FT <sup>3</sup>
BECC01	10	6	4.5	2.5	.20	0.21

**BPHC01 • Cable Terminal Channel**



- Houses various combinations of voice and data cables.
- 2 included with every Raceway Panel.
- Black only.
- For use with Boulevard 1 Panels only.

PRODUCT CODE	PRICE	SIZE/INCHES			WEIGHT VOL	
		H	W	D	LBS	FT <sup>3</sup>
BPHC01	7	2.5	1	2	0.1	0.003

## BOULEVARD SYSTEM 3 PANEL SYSTEM

Boulevard System 3... The next generation of BOULEVARD offers the freedom to plan the office environment 'your way', while keeping an eye on the bottom line. Boulevard System 3 boasts a rich toolbox featuring stack-on panels, complete data/communication lay-in at the top, comprehensive power and data/communication at both the base and at desk height, a selection of interchangeable tiles, monolithic panels, up-mounted storage, new ergonomic worksurface shapes & a revised color pallet featuring recycled fabrics... all wrapped up in a sophisticated design statement. Enjoy planning it your way and having the tools to really do it. Boulevard System 3 offers the building blocks to create the framework that perfectly suits your office environment. Combinations of fabric, glazed, open and slat wall panel surface tiles effectively support the creation of various work settings, whether open (to encourage interaction and teamwork) or traditional, with enclosed functional task organizers. Boulevard System 3 lets you plan more effectively and with more versatility than ever before. It is simple to comprehend,

specify, install, maintain and reconfigure. Offering multifunctional furnishing solutions, Boulevard System 3 can be specified on its own or used as a power/data and privacy provider, bridging freestanding/mobile furniture and panels and task related options such as worksurface shapes that help you work better. By utilizing up-mount storage, lower panel heights can be maintained without sacrificing overhead storage where and when needed. Another value-oriented tool... Consider 'Spine' planning to create a power wall that feeds data/communication to a string of perpendicular offices. Incorporate monolithic panels which offer the best cost/performance advantages for value sensitive environments with base panel raceway power/data cable distribution, while adding visual interest...and of course, reconfiguration is a breeze. Now you can have an endless visual pallet and array of practical solutions for today's ever changing and demanding workplace. When you add it all up, Boulevard System 3 gives you more value than ever before.

## TECHNICAL INFORMATION

### Panels

All panels are 2 5/8" thick.  
Lightweight aluminum box frame construction creates superior panel rigidity.  
Panel frame finish is durable epoxy powder coated.  
Hang-on capabilities at 1" increments.  
Patented "Knuckle-Loc" design provides solid panel-to-panel connection for fast installation and reconfiguration.  
Knuckle lock feature ensures even panel heights throughout installation.  
3" glide stem permits 2 1/2" height adjustment.  
Panel sizes are actual, eliminating creepage.  
Vertical end trims must be specified to give the panel a finished appearance.  
Horizontal top trims are included with all panels.  
All panels include 2 "Capture Strip" panel connectors.  
Panels are UL listed and CSA approved and have a Class "A" fire rating except when Customer's Own Material (COM) is used.  
All panels accept Over Panels (see page D.7).

### Panel Options

Laminate, whiteboard, or corkboard may be substituted for fabric on panels only, see "OPT" column.  
Laminate and whiteboard are held in place with a PVC retainer matching the frame color and can be retrofitted on site.  
Laminate and whiteboard options reduce the acoustical value of the panel.

### Monolithic Panels

- Fabric on Monolithic Panels can be re-upholstered on site.

### Pass-Thru Panels

- Fabric at base of Pass-Thru Panels can be re-upholstered on site.
- Tiles cannot be re-upholstered on site.

### Bottom Lay-in Raceway

Bottom raceway snaps to the bottom of the panel and can be completely removed for unobstructed cable lay-in installation.  
Bottom lay-in raceway is 60 mm (2.380") wide x 141 mm (5.560") high.  
Maximum capacity: 70 cables 5 mm (0.200) diameter, 2 parallel 8 wire, 4 circuit power distribution.  
State-of-the-art engineering.  
Snap-in modularity of all electrical components including harnesses, distribution housings, duplexes and circuit designations.  
All power and data outlets are easily accessible from both sides of panel.  
8 wire system with 4, 15 amp circuits (including 1 dedicated circuit).  
Face-mount electrical with 2 duplex per panel side.  
Included is 1 data/communication terminal bracket per side.

Raceway cover openings of 2.71" x 1.38" can accommodate a single modular Data/Comm terminal plate per side (not supplied by Teknion Inc).  
Opening complies with the ANSI/TIA/EIA standard furniture openings.  
Outlet and circuit changes accomplished without disruption to work station.  
Large raceway cavity permits storage of excess cables and equipment cords.  
Total flexibility for 8 wire system: choice of up to 4 duplexes per panel; choice of circuitry in each duplex .  
Unique design of fire retardant metal raceway cover permits access to raceway without disruption to equipment.

### Horizontal Lay-in Channel (Excluding all panels with Embedded Glass)

Integrated horizontal lay-in channel 33.5 m (1.320") wide and 38 mm (1.500") high at the top of panels and on top of the door frame.  
Maximum capacity: 36 cables 5 mm (0.200") in diameter.  
Maximum cable bending radius between two perpendicular panels: 141.2 mm (5.560") [5 mm (0.200") in diameter cables].

### Vertical Wire Channel

Where applicable, the vertical wire channel connects horizontal channel above desk height with floor level raceway.  
Opening in horizontal channel allows for vertical cable passage from top lay-in channel to base raceway.  
Integrated vertical channel 76 mm (2.990") x 27 mm (1.060").  
Maximum capacity: 60 cables 5 mm (0.200") in diameter.  
Maximum cable bending radius: 141.2 mm (5.560").

### Posts

Enables connection for multiple panel runs such as 90°, 45° or 60° angle and 2 way, 3 way or 4 way.  
Starts at the top of the bottom lay-in raceway.  
90 degree post provides route for ceiling power and data entry to a panel raceway.  
Knuckle lock feature maintains even height of all connected panels.  
Solid lightweight aluminum extrusion fits together through a unique "Knuckle-Loc" design providing rigid post-to-panel connection.  
Post has punch-outs at the top to allow for unobstructed horizontal cable passage between adjacent panels.  
Includes all required panel connectors and caps.  
Posts add 2 5/8" to a panel run.  
Posts are 1/8" oversized to allow for "panel wrap around" of freestanding desks.  
For all panel runs with multiple posts, this 1/8" must be allotted for.  
Maximum capacity:

- 80 cables 5 mm (0.200") diameter
- 65 cables 5 mm (0.200") diameter with 1 power feed
- 50 cables 5 mm (0.200") diameter with 2 power feeds

**PANELS - GUIDELINES FOR ORDERING PRODUCT**

**Codes**

The product guide uses a numbering system with meaningful alphanumeric characters to create a simple-to-understand product number. This makes specifying the product much easier and more accurate.

Example of Panel: **BPX3MA6636 CHR CHR P1 AN50**

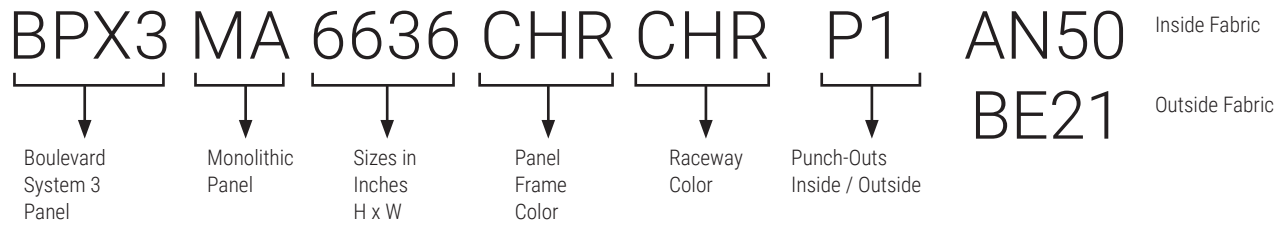

**How to Specify**

Specify Boulevard System 3 panel type and size by code.

Specify panel frame finish - ie. CHR (Charcoal).

Specify PVC raceway finish - ie. CHR (Charcoal). If raceway color not specified at time of order, default will be the panel frame color.

Specify all two panel fabric options if necessary.

Some fabrics have directional pattern and cannot be applied horizontally or vertically. Panels wider than 60" will have fabrics applied horizontally (railroad).

Please specify if you want adjacent panels and the rest of the installation upholstered the same way.

Specify whether punchouts are required inside and outside of raceway or if no knockouts are required.

- P2 - Punch-Outs on both sides.
- P1 - Punch-Outs on one side.
- NP - No punchouts.

For special width panels, a special must be processed and additional costs apply.

Please contact your customer service representative.

Example of Post: **BH3PS066 CHR**

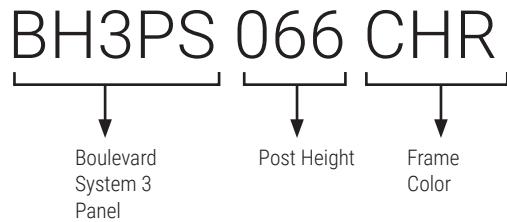

**How to Specify**

Specify Boulevard System 3 post by code.

Specify frame color - ie. CHR (Charcoal).

**ORDERS**

**Each Order Must Include:**

- Purchase Order
- Layout showing where the image(s) appear in the run of panels.
- A completed Price Chart, showing the location of the image(s) on each appropriate panel.

Artwork must be submitted in accordance with the following artwork specifications.

**NOTE:** Final artwork specification approval must be given before order can be processed.

**TRANSFER DEVICES**

- E-mail up to 10MB to your Teknion Customer Service Representative.
- Courier CD/DVD/USB stick to your Teknion Customer Service Representative.

**ARTWORK SPECIFICATIONS**

- Non-Photographic artwork should be vector art, saved in Adobe Illustrator (.ai) or as an EPS (.eps)
- All bitmap or photographic artwork has to be at a minimum of 100 dpi at the full size of the panel to be printed.
- We accept Adobe CS5 files.
- Any linked files must be included or imbedded.
- Leave any PSD files unflattened
- All fonts must be converted to outlines.
- Do not convert to CMYK, leave all images as RGB if possible
- No Word, Powerpoint, Publisher or other Microsoft files can be used.
- Include a PDF or .jpg for reference when sending native Photoshop or Illustrator format files.

**COLOR MATCHING**

A Pantone color reference must be supplied or we cannot accept responsibility for correct color.

When it is not possible to refer to Pantone colors, we will do our best to meet your requirements.

**IMAGE CLARITY**

We will advise should the selected image not lend itself to the element size requested.

**NOTE**

We reserve the right to put an order on hold when the files are found to be incomplete or when documents have been either incorrectly saved. Fonts not

converted to curves or the job appears not to be commercially acceptable.

**IMAGE BLEED**

To facilitate placement on the panel. Extension of the image past the finished visible area of the panel (bleed) is required

- Boulevard Panels need a 5" Bleed on all sides.

**EXAMPLE OF IMAGE RESOLUTION**

The resolution required for a 36 wide x 24 high Boulevard panel at 100dpi (minimum resolution)

The resolution required for a 36 wide x 24 high Boulevard panel at 300dpi (higher quality)

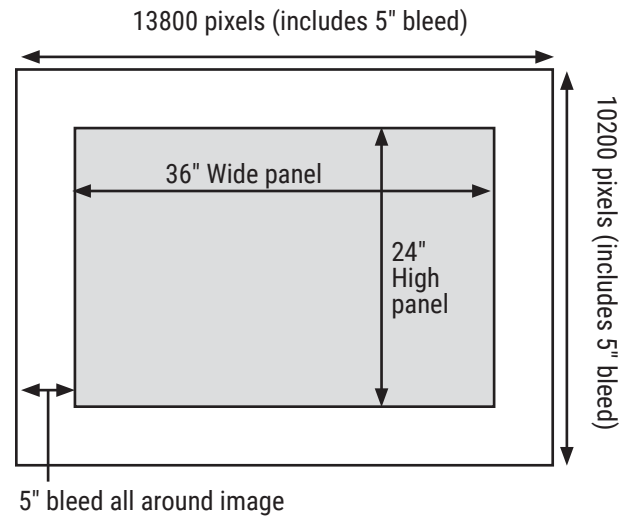
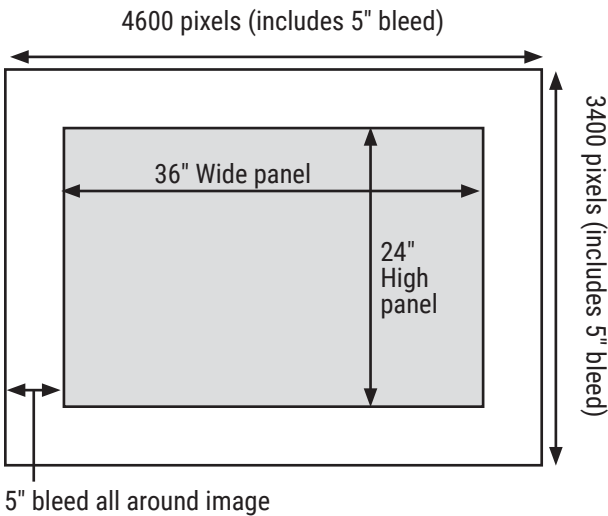



**Pricing, Initial Set-Up Charge per Image: \$235 net**

**Boulevard System 3 Tiles**

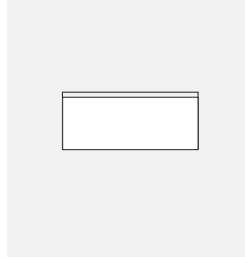

This List applies to the following panels:  
BP3FTxxxx  
BP3ETxxxx

PANEL WIDTH	HEIGHT 8"	LIST PRICE 16"
24"	191	280
30"	226	331
36"	260	381
42"	301	431
48"	331	350
54"	372	540
60"	401	592
66"	431	632
72"	471	681

**Boulevard System 3 Bottom Section of Pass-Thru Panel**

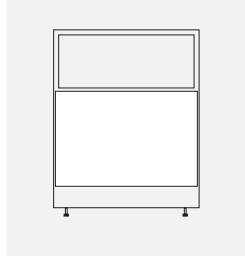

This List applies to the following panels:  
BPX3PTxxxx  
BPX3PVxxxx

PANEL WIDTH	LIST PRICE 28"
24"	401
30"	471
36"	540
42"	621
48"	691
54"	761
60"	832
66"	901
72"	971

**Boulevard System 3 Monolithic Panels**

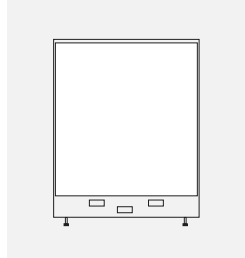

This List applies to the following panels:  
BPX3MAxxxx  
BPX3MVxxxx

PANEL WIDTH	HEIGHT 34"	HEIGHT 42"	HEIGHT 50"	HEIGHT 66"
24"	401	491	572	751
30"	471	572	681	881
36"	540	660	782	1021
42"	621	751	871	1162
48"	691	841	1002	1292
54"	761	930	1091	1432
60"	832	1021	1203	1561
66"	901			
72"	971			

Note: Prices shown are an upcharge to the panel price, please add to the list price of panel which you are specifying the graphic for.

**BPX3MA • Monolithic Acoustical Panel**

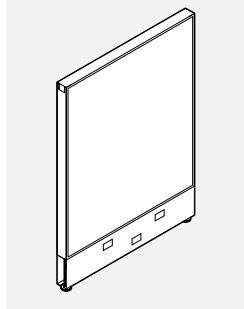

- Provides visual and acoustic privacy.
- Center septum above raceway overlaid on either side with 1 1/8" "Sound absorbent mineral board."
- Acoustic rating of .70 NRC and 25 STC.
- OPT\* = Laminate or Whiteboard
- "No Knockouts" option for raceways available at no additional charge. Please choose option for interior and/or exterior raceways.

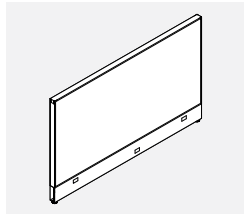

72" Wide

PRODUCT CODE	PRICE			SIZE / INCHES			WEIGHT VOL	
	GR 1	GR 2	OPT*	H	W	D	LBS	FT <sup>3</sup>
BPX3MA3418	313	333	352	34	18	2.61	11	1.337
BPX3MA3424	350	372	392	34	24	2.61	12	1.738
BPX3MA3430	383	404	422	34	30	2.61	13	2.139
BPX3MA3436	419	457	496	34	36	2.61	15	2.540
BPX3MA3442	452	490	531	34	42	2.61	16	2.941
BPX3MA3448	487	524	566	34	48	2.61	18	3.342
BPX3MA3454	523	561	601	34	54	2.61	20	3.743
BPX3MA3460	557	593	636	34	60	2.61	22	4.144
BPX3MA3466	762	815	871	34	66	2.61	26	4.612
BPX3MA3472	965	1018	-	34	72	2.61	30	5.080
BPX3MA4218	338	363	389	42	18	2.61	12	1.782
BPX3MA4224	374	401	426	42	24	2.61	13	2.317
BPX3MA4230	411	437	464	42	30	2.61	15	2.852
BPX3MA4236	447	497	551	42	36	2.61	17	3.387
BPX3MA4242	486	536	590	42	42	2.61	19	3.921
BPX3MA4248	522	572	626	42	48	2.61	21	4.456
BPX3MA4254	561	610	664	42	54	2.61	23	4.991
BPX3MA4260	597	646	701	42	60	2.61	25	5.525
BPX3MA4266	848	951	1060	42	66	2.61	29	6.148
BPX3MA4272	1099	1203	-	42	72	2.61	34	6.770
BPX3MA5018	435	473	514	50	18	2.61	13	2.106
BPX3MA5024	479	517	557	50	24	2.61	15	2.738
BPX3MA5030	523	561	601	50	30	2.61	17	3.370
BPX3MA5036	571	646	728	50	36	2.61	20	4.002
BPX3MA5042	642	717	798	50	42	2.61	23	4.634
BPX3MA5048	660	736	816	50	48	2.61	24	5.266
BPX3MA5054	703	781	859	50	54	2.61	25	5.898
BPX3MA5060	750	826	907	50	60	2.61	27	6.530
BPX3MA5066	1049	1153	1263	50	66	2.61	33	7.265
BPX3MA5072	1346	1450	-	50	72	2.61	40	8.000
BPX3MA5418	490	528	570	54	18	2.61	14	2.406
BPX3MA5424	536	574	616	54	24	2.61	16	3.181
BPX3MA5430	570	605	646	54	30	2.61	19	3.907
BPX3MA5436	633	708	789	54	36	2.61	22	4.602
BPX3MA5442	679	754	835	54	42	2.61	25	5.306
BPX3MA5448	727	802	883	54	48	2.61	26	5.966
BPX3MA5454	770	847	925	54	54	2.61	27	7.287
BPX3MA5460	820	897	977	54	60	2.61	30	7.539
BPX3MA6618	508	570	638	66	18	2.61	14	2.755
BPX3MA6624	555	619	685	66	24	2.61	17	3.581
BPX3MA6630	601	664	734	66	30	2.61	20	4.407
BPX3MA6636	652	751	859	66	36	2.61	24	5.234
BPX3MA6642	700	800	907	66	42	2.61	26	6.060
BPX3MA6648	748	851	956	66	48	2.61	28	6.887
BPX3MA6654	793	896	1003	66	54	2.61	30	7.713
BPX3MA6660	843	945	1052	66	60	2.61	32	8.539

**BPX3MV • Monolithic Acoustical Panel With Vertical Wire Channel**

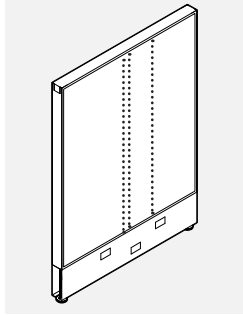

- Provides visual and acoustic privacy and allows for vertical cable passage from top lay-in channel to bottom raceway within panel.
- Center septum above raceway overlaid on either side with 1 1/8" "Sound absorbent mineral board."
- Acoustic rating of .70 NRC and 25 STC. Includes integrated vertical wire channel.
- OPT\* = Laminate or Whiteboard
- "No Knockouts" option for raceways available at no additional charge. Please choose option for interior and/or exterior raceways.

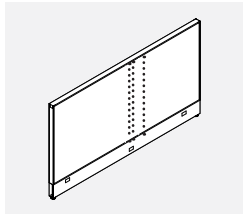

72" Wide

PRODUCT CODE	PRICE			SIZE/INCHES			WEIGHT VOL	
	GR 1	GR 2	OPT*	H	W	D	LBS	FT <sup>3</sup>
BPX3MV3430	414	433	450	34	30	2.61	15	2.139
BPX3MV3436	447	484	530	34	36	2.61	17	2.540
BPX3MV3442	481	519	561	34	42	2.61	18	2.941
BPX3MV3448	518	555	597	34	48	2.61	20	3.342
BPX3MV3454	552	589	631	34	54	2.61	22	3.743
BPX3MV3460	587	624	664	34	60	2.61	24	4.144
BPX3MV3466	808	860	917	34	66	2.61	29	4.612
BPX3MV3472	1027	1061	-	34	72	2.61	34	5.080
BPX3MV4230	503	533	565	42	30	2.61	17	2.852
BPX3MV4236	486	536	590	42	36	2.61	19	3.387
BPX3MV4242	524	576	628	42	42	2.61	21	3.921
BPX3MV4248	561	609	664	42	48	2.61	23	4.456
BPX3MV4254	599	648	703	42	54	2.61	25	4.991
BPX3MV4260	636	685	740	42	60	2.61	27	5.525
BPX3MV4266	908	1010	1122	42	66	2.61	32	6.148
BPX3MV4272	1180	1283	-	42	72	2.61	38	6.770
BPX3MV5030	572	608	652	50	30	2.61	19	3.370
BPX3MV5036	620	696	776	50	36	2.61	22	4.002
BPX3MV5042	662	739	817	50	42	2.61	25	4.634
BPX3MV5048	708	786	865	50	48	2.61	26	5.266
BPX3MV5054	751	829	908	50	54	2.61	27	5.898
BPX3MV5060	798	874	955	50	60	2.61	29	6.530
BPX3MV5066	1126	1227	1339	50	66	2.61	35	7.265
BPX3MV5072	1450	1554	-	50	72	2.61	40	8.000
BPX3MV5430	644	682	724	54	30	2.61	19	3.907
BPX3MV5436	692	768	849	54	36	2.61	22	4.602
BPX3MV5442	741	816	897	54	42	2.61	25	5.306
BPX3MV5448	789	865	945	54	48	2.61	26	5.966
BPX3MV5454	835	911	992	54	54	2.61	27	7.287
BPX3MV5460	881	957	1037	54	60	2.61	30	7.539
BPX3MV6630	669	733	800	66	30	2.61	22	4.407
BPX3MV6636	717	817	924	66	36	2.61	26	5.234
BPX3MV6642	766	867	973	66	42	2.61	28	6.060
BPX3MV6648	815	916	1024	66	48	2.61	30	6.887
BPX3MV6654	860	962	1069	66	54	2.61	32	7.713
BPX3MV6660	910	1010	1118	66	60	2.61	34	8.539

**BPX3MG • Monolithic Glazed Panel**

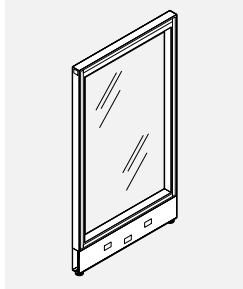

- Full-height glazing provides visual accessibility.
- Glazing is replaceable on site. Tempered clear glass standard.
- Glazing is standard on one side.
- "No Knockouts" option for raceways available at no additional charge. Please choose option for interior and/or exterior raceways.

PRODUCT CODE	PRICE	FRST	SIZE/INCHES			WEIGHT VOL	
			H	W	D	LBS	FT <sup>3</sup>
BPX3MG5024	763	916	50	24	2.61	25	2.738
BPX3MG5030	968	1164	50	30	2.61	29	3.370
BPX3MG5036	1026	1231	50	36	2.61	33	4.002
BPX3MG5042	1081	1297	50	42	2.61	36	4.634
BPX3MG5048	1139	1367	50	48	2.61	41	5.266
BPX3MG5424	763	916	54	24	2.61	29	3.138
BPX3MG5430	968	1164	54	30	2.61	34	3.807
BPX3MG5436	1026	1231	54	36	2.61	38	4.602
BPX3MG5442	1081	1297	54	42	2.61	43	5.334
BPX3MG5448	1139	1367	54	48	2.61	48	6.066
BPX3MG6624	950	1139	66	24	2.61	33	3.581
BPX3MG6630	1031	1237	66	30	2.61	39	4.407
BPX3MG6636	1115	1338	66	36	2.61	44	5.234
BPX3MG6642	1196	1435	66	42	2.61	49	6.060
BPX3MG6648	1275	1531	66	48	2.61	54	6.887

**BPX3PT • Pass-Thru Panel - Fabric Base**

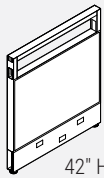

42" High

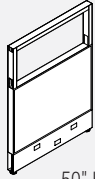

50" High

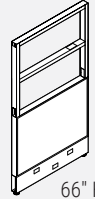

66" High

- Opening allows choice of tile above desk height.
- Solid fabric base up to 34".
- Single 8" opening above 34" for 42" high panels.
- Single 16" opening above 34" for 50" high panels.
- Two individual 16" openings above 34" for 66" high panels.
- Horizontal cable management at 34" height.
- OPT\* = Laminate or Whiteboard.
- "No Knockouts" option for raceways available at no additional charge. Please choose option for interior and/or exterior raceways.

PRODUCT CODE	PRICE			SIZE/INCHES			WEIGHT VOL	
	GR 1	GR 2	OPT*	H	W	D	LBS	FT <sup>3</sup>
BPX3PT4218	323	349	377	42	18	2.61	14	1.689
BPX3PT4224	365	389	419	42	24	2.61	16	2.233
BPX3PT4230	404	430	458	42	30	2.61	17	2.792
BPX3PT4236	441	468	495	42	36	2.61	19	3.351
BPX3PT4242	480	506	534	42	42	2.61	21	3.908
BPX3PT4248	520	546	574	42	48	2.61	23	4.466
BPX3PT4254	558	584	612	42	54	2.61	26	5.025
BPX3PT4260	598	624	652	42	60	2.61	27	5.592
BPX3PT4266	824	876	932	42	66	2.61	32	6.148
BPX3PT4272	1049	1102	-	42	72	2.61	38	6.700
BPX3PT5018	323	349	377	50	18	2.61	15	2.106
BPX3PT5024	365	389	419	50	24	2.61	17	2.738
BPX3PT5030	404	430	458	50	30	2.61	18	3.370
BPX3PT5036	441	468	495	50	36	2.61	20	4.002
BPX3PT5042	479	509	534	50	42	2.61	22	4.634
BPX3PT5048	520	546	574	50	48	2.61	24	5.266
BPX3PT5054	558	584	612	50	54	2.61	27	5.898
BPX3PT5060	598	624	652	50	60	2.61	29	6.530
BPX3PT5066	824	876	932	50	66	2.61	34	7.265
BPX3PT5072	1049	1102	-	50	72	2.61	40	8.000
BPX3PT6618	403	430	457	66	18	2.61	19	2.755
BPX3PT6624	447	475	501	66	24	2.61	21	3.581
BPX3PT6630	495	522	549	66	30	2.61	23	4.407
BPX3PT6636	544	570	597	66	36	2.61	25	5.234
BPX3PT6642	589	617	642	66	42	2.61	27	6.060
BPX3PT6648	637	663	691	66	48	2.61	30	6.887
BPX3PT6654	684	709	739	66	54	2.61	33	7.713
BPX3PT6660	733	759	787	66	60	2.61	36	8.539

**BPX3PV • Pass-Thru Panel With Vertical Wire Channel**

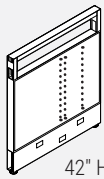

42" High

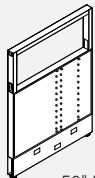

50" High

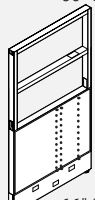

66" High

- Opening allows choice of tile above desk height. Vertical wire channel allows passage of cables from top lay-in channel to bottom raceway within panel.
- Solid fabric base up to 34".
- Single 8" opening above 34" for 42" high panels.
- Single 16" opening above 34" for 50" high panels.
- Two individual 16" openings above 34" for 66" high panels.
- Includes integrated vertical wire channel.
- Horizontal cable management at 34" height.
- OPT\* = Laminate or Whiteboard.
- "No Knockouts" option for raceways available at no additional charge. Please choose option for interior and or exterior raceways.

PRODUCT CODE	PRICE			SIZE/INCHES			WEIGHT VOL	
	GR 1	GR 2	OPT*	H	W	D	LBS	FT <sup>3</sup>
BPX3PV4230	441	468	495	42	30	2.61	19	2.792
BPX3PV4236	480	506	534	42	36	2.61	21	3.351
BPX3PV4242	520	546	574	42	42	2.61	23	3.908
BPX3PV4248	558	584	612	42	48	2.61	23	4.466
BPX3PV4254	598	624	652	42	54	2.61	28	5.025
BPX3PV4260	638	663	692	42	60	2.61	30	5.592
BPX3PV4266	863	917	972	42	66	2.61	36	6.148
BPX3PV4272	1089	1142	-	42	72	2.61	42	6.700
BPX3PV5030	441	468	495	50	30	2.61	20	3.370
BPX3PV5036	480	506	534	50	36	2.61	22	4.002
BPX3PV5042	520	546	574	50	42	2.61	24	4.634
BPX3PV5048	558	584	612	50	48	2.61	26	5.266
BPX3PV5054	598	624	652	50	54	2.61	29	5.898
BPX3PV5060	638	663	692	50	60	2.61	31	6.530
BPX3PV5066	863	917	972	50	66	2.61	37	7.265
BPX3PV5072	1089	1142	-	50	72	2.61	44	8.000
BPX3PV6630	534	561	588	66	30	2.61	25	4.407
BPX3PV6636	581	608	637	66	36	2.61	27	5.234
BPX3PV6642	628	657	682	66	42	2.61	29	6.060
BPX3PV6648	678	703	732	66	48	2.61	32	6.887
BPX3PV6654	723	749	777	66	54	2.61	35	7.713
BPX3PV6660	768	794	822	66	60	2.61	38	8.539

**BPX3PF • Pass-Thru Panel - Air Flow Base**

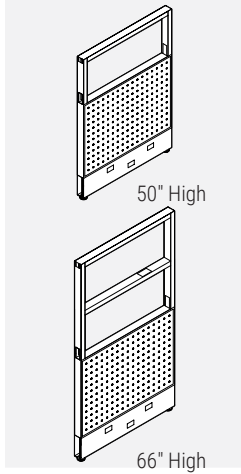

- Allows air to flow freely through the bottom of the panel.
- Double wall perforated metal base up to 34".
- Single 16" opening above 34" for 50" high panels.
- Two individual 16" openings above 34" for 66" high panels.
- Horizontal cable management at 34" height.
- "No Knockouts" option for raceways available at no additional charge. Please choose option for interior and/or exterior raceways.

PRODUCT CODE	PRICE	SIZE/INCHES			WEIGHT VOL	
		H	W	D	LBS	FT <sup>3</sup>
BPX3PF5018	450	50	18	2.61	17	2.106
BPX3PF5024	514	50	24	2.61	18	2.738
BPX3PF5030	574	50	30	2.61	20	3.370
BPX3PF5036	636	50	36	2.61	22	4.002
BPX3PF5042	698	50	42	2.61	23	4.634
BPX3PF5048	759	50	48	2.61	26	5.266
BPX3PF5054	820	50	54	2.61	28	5.898
BPX3PF5060	883	50	60	2.61	31	6.530
BPX3PF6618	528	66	18	2.61	21	2.755
BPX3PF6624	598	66	24	2.61	23	3.581
BPX3PF6630	669	66	30	2.61	25	4.407
BPX3PF6636	741	66	36	2.61	27	5.234
BPX3PF6642	815	66	42	2.61	29	6.060
BPX3PF6648	886	66	48	2.61	32	6.887
BPX3PF6654	957	66	54	2.61	35	7.713
BPX3PF6660	1029	66	60	2.61	37	8.539

**BPX3OP • Over Panel Frame**

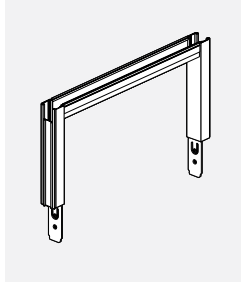

- **Attaches to the top of any Boulevard System 3 panel to create a floor-to-ceiling wall.**
- Any tile can be attached to either side to enclose the frame.
- Two non-slotted uprights at either end slide into vertical extrusions on the base panel.
- Shipped without horizontal and vertical trim; the horizontal trim from the base panel will be used.
- Openings in horizontal channels allow for vertical cable passage from top lay-in channel and behind the cover tiles
- Over Panel Frames 18" and 24" wide are not punched for vertical wire channel.
- Boulevard System 3 Over Panel is not compatible with Boulevard 1 panels.

PRODUCT CODE	PRICE	SIZE/INCHES			WEIGHT VOL	
		H	W	D	LBS	FT <sup>3</sup>
BPX3OP0818	77	8	18	2.61	3	0.383
BPX3OP0824	85	8	24	2.61	4	0.438
BPX3OP0830	93	8	30	2.61	4	0.656
BPX3OP0836	101	8	36	2.61	4	0.712
BPX3OP0842	110	8	42	2.61	5	0.875
BPX3OP0848	117	8	48	2.61	5	0.930
BPX3OP0854	124	8	54	2.61	6	1.040
BPX3OP0860	131	8	60	2.61	6	1.204
BPX3OP0866	191	8	66	2.61	7	1.310
BPX3OP0872	249	8	72	2.61	8	1.420
BPX3OP1618	77	16	18	2.61	4	0.638
BPX3OP1624	85	16	24	2.61	5	0.730
BPX3OP1630	93	16	30	2.61	5	1.094
BPX3OP1636	101	16	36	2.61	5	1.186
BPX3OP1642	110	16	42	2.61	6	1.459
BPX3OP1648	117	16	48	2.61	6	1.550
BPX3OP1654	124	16	54	2.61	7	1.733
BPX3OP1660	131	16	60	2.61	7	2.006
BPX3OP1666	191	16	66	2.61	9	2.165
BPX3OP1672	249	16	72	2.61	10	2.370

**BPX3GMA • Monolithic Acoustical Panel With Embedded Glass**

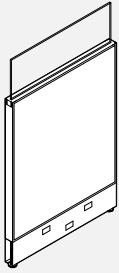

- Provides visual and acoustic privacy.
- Center septum above raceway overlaid on either side with 1 1/8" "Sound absorbent mineral board."
- Acoustic rating of .70 NRC and 25 STC.
- OPT\* = Laminate or Whiteboard
- B3 panel top trim option provided with embedded, frame-less glass pane rising 8" above the top of the panel. For instance, when installed on 42" high B3 panel, overall height will be 50" high.
- There is 1.25" gap between two adjacent glass panes.
- Glass shipped separately, Allen key to set the glass pane plumb is provided with each panel.
- 6 mm tempered glass, frosted or clear.
- Square corners on glass.
- Integrated adjustable brackets and extruded aluminum trim.
- Not retrofittable on-site.
- 16" Glass available as an option, please tag 16" and add the following upcharge per panel size.

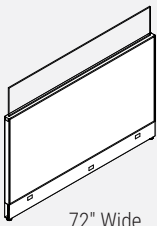

**UPCHARGES FOR 16" GLASS**

PANEL WIDTH	LIST
18	104
24	114
30	124
36	133
42	142
48	152
54	162
60	171
66	180
72	190

PRODUCT CODE	PRICE			SIZE / INCHES			WEIGHT VOL	
	GR1	GR2	OPT*	H	W	D	LBS	FT <sup>3</sup>
BPX3GMA3418	605	627	651	34	18	2.61	14	1.627
BPX3GMA3424	668	691	716	34	24	2.61	17	2.178
BPX3GMA3430	730	756	776	34	30	2.61	20	2.729
BPX3GMA3436	795	840	886	34	36	2.61	23	3.270
BPX3GMA3442	857	901	950	34	42	2.61	25	3.791
BPX3GMA3448	917	961	1009	34	48	2.61	29	4.302
BPX3GMA3454	977	1021	1068	34	54	2.61	32	4.853
BPX3GMA3460	1035	1076	1126	34	60	2.61	35	5.404
BPX3GMA3466	1138	1183	1237	34	66	2.61	40	6.022
BPX3GMA3472	1252	1302	-	34	72	2.61	46	6.640
BPX3GMA4218	632	663	692	42	18	2.61	15	2.072
BPX3GMA4224	696	727	756	42	24	2.61	18	2.757
BPX3GMA4230	765	795	826	42	30	2.61	22	3.442
BPX3GMA4236	829	887	950	42	36	2.61	25	4.117
BPX3GMA4242	896	956	1018	42	42	2.61	28	4.771
BPX3GMA4248	957	1015	1079	42	48	2.61	32	5.416
BPX3GMA4254	1021	1079	1140	42	54	2.61	35	6.101
BPX3GMA4260	1080	1138	1202	42	60	2.61	38	6.785
BPX3GMA4266	1187	1252	1321	42	66	2.61	44	7.558
BPX3GMA4272	1306	1377	-	42	72	2.61	50	8.330
BPX3GMA5018	746	790	840	50	18	2.61	16	2.396
BPX3GMA5024	817	862	910	50	24	2.61	20	3.178
BPX3GMA5030	895	939	986	50	30	2.61	24	3.960
BPX3GMA5036	972	1060	1155	50	36	2.61	28	4.732
BPX3GMA5042	1079	1166	1261	50	42	2.61	32	5.484
BPX3GMA5048	1118	1208	1300	50	48	2.61	35	6.226
BPX3GMA5054	1186	1275	1367	50	54	2.61	37	7.008
BPX3GMA5060	1259	1348	1441	50	60	2.61	40	7.790
BPX3GMA5066	1386	1483	1586	50	66	2.61	48	8.675
BPX3GMA5072	1524	1631	-	50	72	2.61	56	9.560
BPX3GMA5418	810	854	902	54	18	2.61	16	2.704
BPX3GMA5424	885	928	977	54	24	2.61	21	3.678
BPX3GMA5430	949	992	1038	54	30	2.61	26	4.560
BPX3GMA5436	1046	1133	1227	54	36	2.61	30	5.332
BPX3GMA5442	1122	1209	1304	54	42	2.61	34	7.126
BPX3GMA5448	1196	1283	1378	54	48	2.61	38	7.923
BPX3GMA5454	1264	1353	1446	54	54	2.61	41	8.423
BPX3GMA5460	1342	1431	1523	54	60	2.61	47	9.219
BPX3GMA6618	832	902	983	66	18	2.61	17	3.045
BPX3GMA6624	905	979	1057	66	24	2.61	22	4.021
BPX3GMA6630	986	1059	1140	66	30	2.61	27	4.997
BPX3GMA6636	1068	1183	1310	66	36	2.61	32	5.964
BPX3GMA6642	1145	1264	1387	66	42	2.61	35	6.910
BPX3GMA6648	1220	1340	1463	66	48	2.61	39	7.847
BPX3GMA6654	1291	1410	1534	66	54	2.61	42	8.823
BPX3GMA6660	1367	1486	1610	66	60	2.61	45	9.799

**BPX3GMG • Monolithic Glazed Panel With Embedded Glass**

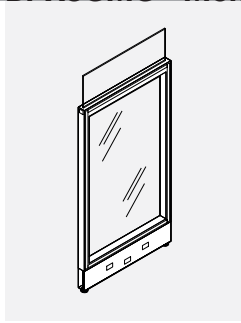

- Full-height glazing provides visual accessibility.
- Glazing is replaceable on site. Tempered clear glass standard.
- B3 panel top trim option provided with embedded, frame-less glass pane rising 8" above the top of the panel. For instance, when installed on 42" high B3 panel, overall height will be 50" high.
- There is 1.25" gap between two adjacent glass panes.
- Glass shipped separately, Allen key to set the glass pane plumb is provided with each panel.
- 6 mm tempered glass, frosted or clear.
- Square corners on glass.
- Integrated adjustable brackets and extruded aluminum trim.
- Not retrofitable on-site.

PRODUCT CODE	PRICE	FRST	SIZE / INCHES			WEIGHT VOL	
			H	W	D	LBS	FT <sup>3</sup>
BPX3GMG5024	1148	1326	50	24	2.61	30	3.178
BPX3GMG5030	1414	1640	50	30	2.61	36	3.960
BPX3GMG5036	1504	1743	50	36	2.61	41	4.732
BPX3GMG5042	1591	1842	50	42	2.61	45	5.484
BPX3GMG5048	1677	1942	50	48	2.61	52	6.226
BPX3GMG5424	1148	1326	54	24	2.61	32	3.678
BPX3GMG5430	1414	1640	54	30	2.61	40	4.360
BPX3GMG5436	1504	1743	54	36	2.61	46	5.317
BPX3GMG5442	1591	1842	54	42	2.61	52	6.010
BPX3GMG5448	1677	1942	54	48	2.61	56	6.890
BPX3GMG6624	1365	1587	66	24	2.61	38	4.021
BPX3GMG6630	1486	1727	66	30	2.61	46	4.997
BPX3GMG6636	1607	1866	66	36	2.61	52	5.964
BPX3GMG6642	1723	2003	66	42	2.61	58	6.910
BPX3GMG6648	1836	2133	66	48	2.61	65	7.847

**BPX3GPT • Pass-Thru Panel With Embedded Glass - Fabric Base**

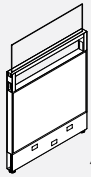

42" High

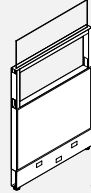

50" High

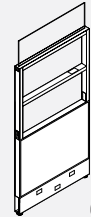

66" High

- Opening allows choice of tile above desk height.
- Solid fabric base up to 34".
- Single 8" opening above 34" for 42" high panels.
- Single 16" opening above 34" for 50" high panels.
- Two individual 16" openings above 34" for 66" high panels.
- Horizontal cable management at 34" height.
- OPT\* = Laminate or Whiteboard.
- B3 panel Top trim option provided with embedded, frame-less glass pane rising 8" above the top of the panel. For instance, when installed on 42" high B3 panel, overall height will be 50" high.
- There is 1.25" gap between two adjacent glass panes.
- Glass shipped separately.
- 6 mm tempered glass, frosted or clear.
- Square corners on glass.
- Integrated adjustable brackets and extruded aluminum trim.
- Not retrofittable on-site.

PRODUCT CODE	PRICE			SIZE / INCHES			WEIGHT VOL	
	GR 1	GR 2	OPT*	H	W	D	LBS	FT <sup>3</sup>
BPX3GPT4218	616	646	678	42	18	2.61	17	1.979
BPX3GPT4224	684	713	746	42	24	2.61	21	2.673
BPX3GPT4230	756	787	817	42	30	2.61	24	3.382
BPX3GPT4236	822	852	885	42	36	2.61	27	4.081
BPX3GPT4242	890	919	954	42	42	2.61	30	4.758
BPX3GPT4248	956	984	1018	42	48	2.61	34	5.426
BPX3GPT4254	1018	1048	1080	42	54	2.61	38	6.135
BPX3GPT4260	1083	1112	1145	42	60	2.61	40	6.852
BPX3GPT4266	1191	1224	1261	42	66	2.61	47	7.556
BPX3GPT4272	1310	1346	-	42	72	2.61	54	8.260
BPX3GPT5018	616	646	678	50	18	2.61	18	2.396
BPX3GPT5024	684	713	746	50	24	2.61	22	3.178
BPX3GPT5030	756	787	817	50	30	2.61	25	3.960
BPX3GPT5036	822	852	885	50	36	2.61	28	4.732
BPX3GPT5042	889	924	954	50	42	2.61	31	5.484
BPX3GPT5048	956	984	1018	50	48	2.61	35	6.226
BPX3GPT5054	1018	1048	1080	50	54	2.61	39	7.008
BPX3GPT5060	1083	1112	1145	50	60	2.61	42	7.790
BPX3GPT5066	1191	1224	1261	50	66	2.61	49	8.675
BPX3GPT5072	1310	1346	-	50	72	2.61	56	9.560
BPX3GPT6618	708	741	771	66	18	2.61	22	3.045
BPX3GPT6624	781	813	842	66	24	2.61	26	4.021
BPX3GPT6630	862	894	924	66	30	2.61	30	4.997
BPX3GPT6636	940	971	1003	66	36	2.61	33	5.964
BPX3GPT6642	1016	1049	1079	66	42	2.61	36	6.910
BPX3GPT6648	1091	1122	1154	66	48	2.61	41	7.847
BPX3GPT6654	1164	1193	1227	66	54	2.61	45	8.823
BPX3GPT6660	1238	1269	1302	66	60	2.61	49	9.799



**BPX3GPV • Pass-Thru Panel With Vertical Wire Channel and Embedded Glass - Fabric Base**

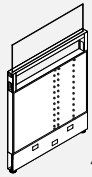

42" High

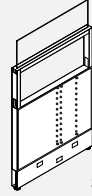

50" High

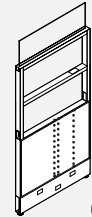

66" High

- Opening allows choice of tile above desk height. Vertical wire channel allows passage of cables from lay-in channel to bottom raceway within panel.
- Solid fabric base up to 34".
- Single 8" opening above 34" for 42" high panels.
- Single 16" opening above 34" for 50" high panels.
- Two individual 16" openings above 34" for 66" high panels.
- Includes integrated vertical wire channel.
- Horizontal cable management at 34" height.
- OPT\* = Laminate or Whiteboard.
- B3 panel Top trim option provided with embedded, frame-less glass pane rising 8" above the top of the panel. For instance, when installed on 42" high B3 panel, overall height will be 50" high.
- There is 1.25" gap between two adjacent glass panes.
- Glass shipped separately, Allen key to set the glass pane plumb is provided with each panel.
- 6 mm tempered glass, frosted or clear.
- Square corners on glass.
- Integrated adjustable brackets and extruded aluminum trim.
- Not retrofittable on-site.

PRODUCT CODE	PRICE			SIZE/INCHES			WEIGHT VOL	
	GR1	GR2	OPT*	H	W	D	LBS	FT <sup>3</sup>
BPX3GPV4230	799	830	862	42	30	2.61	26	3.382
BPX3GPV4236	868	896	930	42	36	2.61	29	4.081
BPX3GPV4242	938	966	1000	42	42	2.61	32	4.758
BPX3GPV4248	1000	1030	1062	42	48	2.61	37	5.426
BPX3GPV4254	1063	1094	1128	42	54	2.61	40	6.135
BPX3GPV4260	1129	1157	1192	42	60	2.61	43	6.852
BPX3GPV4266	1241	1274	1311	42	66	2.61	51	7.556
BPX3GPV4272	1365	1402	-	42	72	2.61	58	8.260
BPX3GPV5030	799	830	862	50	30	2.61	27	3.960
BPX3GPV5036	868	896	930	50	36	2.61	30	4.732
BPX3GPV5042	938	966	1000	50	42	2.61	33	5.484
BPX3GPV5048	1000	1030	1062	50	48	2.61	37	6.226
BPX3GPV5054	1063	1094	1128	50	54	2.61	41	7.008
BPX3GPV5060	1129	1157	1192	50	60	2.61	44	7.790
BPX3GPV5066	1241	1274	1311	50	66	2.61	52	8.675
BPX3GPV5072	1365	1402	-	50	72	2.61	60	9.560
BPX3GPV6630	908	939	970	66	30	2.61	32	4.997
BPX3GPV6636	984	1016	1049	66	36	2.61	35	5.964
BPX3GPV6642	1063	1095	1126	66	42	2.61	38	6.910
BPX3GPV6648	1138	1169	1202	66	48	2.61	43	7.847
BPX3GPV6654	1209	1238	1273	66	54	2.61	47	8.823
BPX3GPV6660	1280	1311	1343	66	60	2.61	51	9.799

**BPX3GPF • Pass-Thru Panel With Embedded Glass - Air Flow Base**

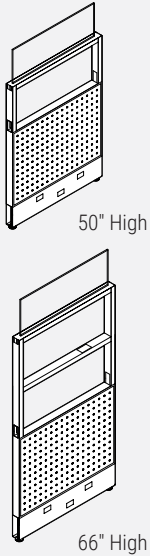

- Allows air to flow freely through the bottom of the panel.
- Double wall perforated metal base up to 34".
- Single 16" opening above 34" for 50" high panels.
- Two individual 16" openings above 34" for 66" high panels.
- Horizontal cable management at 34" height.
- B3 panel Top trim option provided with embedded, frame-less glass pane rising 8" above the top of the panel. For instance, when installed on 42" high B3 panel, overall height will be 50" high.
- There is 1.25" gap between two adjacent glass panes.
- Glass shipped separately, Allen key to set the glass pane plumb is provided with each panel.
- 6 mm tempered glass, frosted or clear.
- Square corners on glass.
- Integrated adjustable brackets and extruded aluminum trim.
- Not retrofiteable on-site.

PRODUCT CODE	PRICE	SIZE / INCHES			WEIGHT VOL	
		H	W	D	LBS	FT <sup>3</sup>
BPX3GPF5018	765	50	18	2.61	20	2.396
BPX3GPF5024	858	50	24	2.61	23	3.178
BPX3GPF5030	955	50	30	2.61	27	3.960
BPX3GPF5036	1048	50	36	2.61	30	4.732
BPX3GPF5042	1144	50	42	2.61	32	5.484
BPX3GPF5048	1234	50	48	2.61	37	6.226
BPX3GPF5054	1322	50	54	2.61	40	7.008
BPX3GPF5060	1414	50	60	2.61	44	7.790
BPX3GPF6618	854	66	18	2.61	24	3.045
BPX3GPF6624	956	66	24	2.61	28	4.021
BPX3GPF6630	1064	66	30	2.61	32	4.997
BPX3GPF6636	1171	66	36	2.61	35	5.964
BPX3GPF6642	1280	66	42	2.61	38	6.910
BPX3GPF6648	1382	66	48	2.61	43	7.847
BPX3GPF6654	1482	66	54	2.61	47	8.823
BPX3GPF6660	1585	66	60	2.61	50	9.799

**BPX3GOP • Over Panel Frame With Embedded Glass**

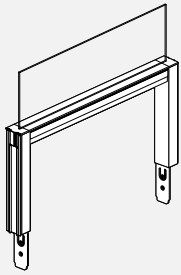

- Attaches to the top of any Boulevard System 3 panel to create a floor-to-ceiling wall.
- Any tile can be attached to either side to enclose the frame.
- Two non-slotted uprights at either end slide into vertical extrusions on the base panel.
- Shipped without horizontal and vertical trim; the horizontal trim from the base panel will be used.
- Boulevard System 3 Over Panel is not compatible with Boulevard 1 panels.
- B3 panel Top trim option provided with embedded, frame-less glass pane rising 8" above the top of the panel. For instance, when installed on 42" high B3 panel, overall height will be 50" high.
- There is 1.25" gap between two adjacent glass panes.
- Glass shipped separately, Allen key to set the glass pane plumb is provided with each panel.
- 5 mm tempered glass, frosted or clear.
- Square corners on glass.
- Integrated adjustable brackets and extruded aluminum trim.
- Not retrofiteable on-site.

PRODUCT CODE	PRICE	SIZE / INCHES			WEIGHT VOL	
		H	W	D	LBS	FT <sup>3</sup>
BPX3GOP0818	329	8	18	2.61	6	0.673
BPX3GOP0824	357	8	24	2.61	9	0.878
BPX3GOP0830	394	8	30	2.61	11	1.246
BPX3GOP0836	426	8	36	2.61	12	1.442
BPX3GOP0842	458	8	42	2.61	14	1.725
BPX3GOP0848	484	8	48	2.61	16	1.890
BPX3GOP0854	511	8	54	2.61	18	2.150
BPX3GOP0860	539	8	60	2.61	19	2.464
BPX3GOP0866	593	8	66	2.61	22	2.722
BPX3GOP0872	652	8	72	2.61	24	2.980
BPX3GOP1618	329	16	18	2.61	7	0.928
BPX3GOP1624	357	16	24	2.61	10	1.170
BPX3GOP1630	394	16	30	2.61	12	1.684
BPX3GOP1636	426	16	36	2.61	13	1.916
BPX3GOP1642	458	16	42	2.61	15	2.309
BPX3GOP1648	484	16	48	2.61	17	2.510
BPX3GOP1654	511	16	54	2.61	19	2.843
BPX3GOP1660	539	16	60	2.61	20	3.266
BPX3GOP1666	593	16	66	2.61	23	3.598
BPX3GOP1672	652	16	72	2.61	26	3.930

**BPX3TMA • Monolithic Acoustical Panel With Embedded Felt Divider**

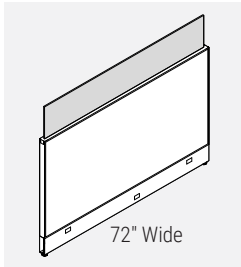
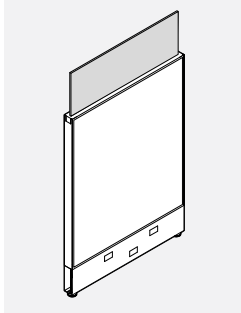

- Provides visual and acoustic privacy
- B3 panel top trim option provided with embedded, frame-less felt panel rising 8" or 16" above the top of the panel. For instance, when installed on 42" high B3 panel, overall height will be 50" high for 8" and 58" high for 16".
- There is 1.25" gap between two adjacent felt panels.
- Felt panel shipped separately.
- 9 mm Felt material is tackable and comes in 18 different colors. Please specify color.
- NOTE: List price shown is for 8" high felt only.

PRODUCT CODE	PRICE			SIZE/INCHES			WEIGHT VOL	
	GR1	GR2	OPT*	H	W	D	LBS	FT <sup>3</sup>
BPX3TMA3418	563	592	622	34	18	2.61	11.9	1.627
BPX3TMA3424	630	657	689	34	24	2.61	14.1	2.178
BPX3TMA3430	696	724	754	34	30	2.61	16.3	2.729
BPX3TMA3436	761	819	879	34	36	2.61	18.5	3.270
BPX3TMA3442	832	889	950	34	42	2.61	19.7	3.791
BPX3TMA3448	897	955	1015	34	48	2.61	22.8	4.302
BPX3TMA3454	978	1033	1094	34	54	2.61	25.0	4.853
BPX3TMA3460	1042	1099	1161	34	60	2.61	27.2	5.404
BPX3TMA3466	1107	1186	1273	34	66	2.61	31.4	6.022
BPX3TMA3472	1170	1248	-	34	72	2.61	36.6	6.640
BPX3TMA4218	600	638	679	42	18	2.61	12.9	2.072
BPX3TMA4224	670	709	750	42	24	2.61	15.1	2.757
BPX3TMA4230	740	778	819	42	30	2.61	18.3	3.442
BPX3TMA4236	809	885	966	42	36	2.61	20.5	4.117
BPX3TMA4242	883	960	1041	42	42	2.61	22.7	4.771
BPX3TMA4248	955	1031	1112	42	48	2.61	25.8	5.416
BPX3TMA4254	1033	1111	1192	42	54	2.61	28.0	6.101
BPX3TMA4260	1101	1178	1259	42	60	2.61	30.2	6.785
BPX3TMA4266	1207	1361	1531	42	66	2.61	35.4	7.558
BPX3TMA4272	1308	1466	-	42	72	2.61	40.6	8.330
BPX3TMA5018	752	809	870	50	18	2.61	13.9	2.396
BPX3TMA5024	835	891	952	50	24	2.61	17.1	3.178
BPX3TMA5030	922	977	1037	50	30	2.61	20.3	3.960
BPX3TMA5036	1000	1115	1238	50	36	2.61	23.5	4.732
BPX3TMA5042	1087	1202	1324	50	42	2.61	26.7	5.484
BPX3TMA5048	1170	1284	1408	50	48	2.61	28.8	6.226
BPX3TMA5054	1262	1375	1497	50	54	2.61	30.0	7.008
BPX3TMA5060	1346	1461	1583	50	60	2.61	32.2	7.790
BPX3TMA5066	1457	1613	1780	50	66	2.61	39.4	8.675
BPX3TMA5072	1564	1721	-	50	72	2.61	46.6	9.560
BPX3TMA5418	782	837	900	54	18	2.61	13.9	2.704
BPX3TMA5424	864	922	982	54	24	2.61	18.1	3.678
BPX3TMA5430	950	1009	1069	54	30	2.61	22.3	4.560
BPX3TMA5436	1033	1148	1272	54	36	2.61	25.5	5.332
BPX3TMA5442	1122	1236	1360	54	42	2.61	28.7	7.126
BPX3TMA5448	1204	1317	1442	54	48	2.61	31.8	7.923
BPX3TMA5454	1297	1410	1534	54	54	2.61	34.0	8.423
BPX3TMA5460	1383	1497	1620	54	60	2.61	39.2	9.219
BPX3TMA6618	868	964	1065	66	18	2.61	14.9	3.045
BPX3TMA6624	959	1053	1156	66	24	2.61	19.1	4.021
BPX3TMA6630	1041	1137	1237	66	30	2.61	23.3	4.997
BPX3TMA6636	1130	1283	1445	66	36	2.61	27.5	5.964
BPX3TMA6642	1223	1375	1538	66	42	2.61	29.7	6.910
BPX3TMA6648	1308	1462	1624	66	48	2.61	32.8	7.847
BPX3TMA6654	1405	1558	1720	66	54	2.61	35.0	8.823
BPX3TMA6660	1495	1647	1810	66	60	2.61	37.2	9.799

**BPX3TMG • Monolithic Glazed Panel With Embedded Felt Divider**

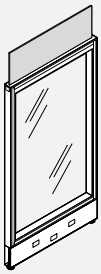

- Full-height glazing provides visual accessibility.
- B3 panel top trim option provided with embedded, frame-less felt panel rising 8" or 16" above the top of the panel. For instance, when installed on 42" high B3 panel, overall height will be 50" high for 8" and 58" high for 16".
- There is 1.25" gap between two adjacent felt panels.
- Felt panel shipped separately.
- 9 mm Felt material is tackable and comes in 18 different colors. Please specify color.
- NOTE: List price shown is for 8" high felt only.

PRODUCT CODE	PRICE	FRST	SIZE/INCHES			WEIGHT VOL	
			H	W	D	LBS	FT <sup>3</sup>
BPX3TMG5024	1288	1529	50	24	2.61	27.1	3.178
BPX3TMG5030	1624	1928	50	30	2.61	32.3	3.960
BPX3TMG5036	1726	2050	50	36	2.61	36.5	4.732
BPX3TMG5042	1830	2174	50	42	2.61	39.7	5.484
BPX3TMG5048	1932	2292	50	48	2.61	45.8	6.226
BPX3TMG5424	1365	1621	54	24	2.61	29.1	3.678
BPX3TMG5430	1651	1961	54	30	2.61	36.3	4.360
BPX3TMG5436	1763	2095	54	36	2.61	41.5	5.317
BPX3TMG5442	1874	2228	54	42	2.61	46.7	6.010
BPX3TMG5448	1986	2359	54	48	2.61	49.8	6.890
BPX3TMG6624	1583	1887	66	24	2.61	35.1	4.021
BPX3TMG6630	1723	2051	66	30	2.61	42.3	4.997
BPX3TMG6636	1872	2227	66	36	2.61	47.5	5.964
BPX3TMG6642	2012	2390	66	42	2.61	52.7	6.910
BPX3TMG6648	2150	2555	66	48	2.61	58.8	7.847

**BPX3TPT • Pass-Thru Panel With Embedded Felt Divider**

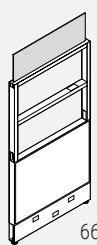
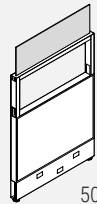
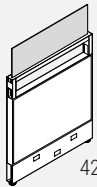

- Opening allows choice of tile above desk height.
- B3 panel top trim option provided with embedded, frame-less felt panel rising 8" or 16" above the top of the panel. For instance, when installed on 42" high B3 panel, overall height will be 50" high for 8" and 58" high for 16".
- There is 1.25" gap between two adjacent felt panels.
- Felt panel shipped separately.
- 9 mm Felt material is tackable and comes in 18 different colors. Please specify color.
- NOTE: List price shown is for 8" high felt only.

PRODUCT CODE	PRICE			SIZE/INCHES			WEIGHT VOL	
	GR 1	GR 2	OPT*	H	W	D	LBS	FT <sup>3</sup>
BPX3TPT4218	577	615	658	42	18	2.61	17	1.979
BPX3TPT4224	653	692	734	42	24	2.61	21	2.673
BPX3TPT4230	727	765	808	42	30	2.61	24	3.382
BPX3TPT4236	798	836	879	42	36	2.61	27	4.081
BPX3TPT4242	873	911	954	42	42	2.61	30	4.758
BPX3TPT4248	949	988	1031	42	48	2.61	34	5.426
BPX3TPT4254	1032	1070	1113	42	54	2.61	38	6.135
BPX3TPT4260	1102	1142	1183	42	60	2.61	40	6.852
BPX3TPT4266	1180	1259	1346	42	66	2.61	47	7.556
BPX3TPT4272	1257	1335	-	42	72	2.61	54	8.260
BPX3TPT5018	577	615	658	50	18	2.61	18	2.396
BPX3TPT5024	653	692	734	50	24	2.61	22	3.178
BPX3TPT5030	727	765	808	50	30	2.61	25	3.960
BPX3TPT5036	798	836	879	50	36	2.61	28	4.732
BPX3TPT5042	873	911	954	50	42	2.61	31	5.484
BPX3TPT5048	949	988	1031	50	48	2.61	35	6.226
BPX3TPT5054	1032	1070	1113	50	54	2.61	39	7.008
BPX3TPT5060	1102	1142	1183	50	60	2.61	42	7.790
BPX3TPT5066	1180	1259	1346	50	66	2.61	49	8.675
BPX3TPT5072	1257	1335	-	50	72	2.61	56	9.560
BPX3TPT6618	669	709	750	66	18	2.61	22	3.045
BPX3TPT6624	757	798	838	66	24	2.61	26	4.021
BPX3TPT6630	848	889	929	66	30	2.61	30	4.997
BPX3TPT6636	933	973	1014	66	36	2.61	33	5.964
BPX3TPT6642	1024	1064	1105	66	42	2.61	36	6.910
BPX3TPT6648	1117	1157	1198	66	48	2.61	41	7.847
BPX3TPT6654	1216	1257	1297	66	54	2.61	45	8.823
BPX3TPT6660	1307	1348	1388	66	60	2.61	49	9.799

**BPX3TPV • Pass-Thru Panel With Vertical Wire Channel and Embedded Felt Divider - Fabric Base**

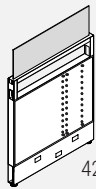

42" High

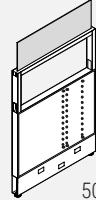

50" High

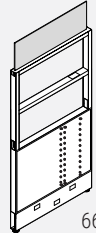

66" High

- Opening allows choice of tile above desk height. Vertical wire channel allows passage of cables from lay-in channel to bottom raceway within panel.
- B3 panel top trim option provided with embedded, frame-less felt panel rising 8" or 16" above the top of the panel. For instance, when installed on 42" high B3 panel, overall height will be 50" high for 8" and 58" high for 16".
- There is 1.25" gap between two adjacent felt panels.
- Felt panel shipped separately.
- 9 mm Felt material is tackable and comes in 18 different colors. Please specify color.
- NOTE: List price shown is for 8" high felt only.

PRODUCT CODE	PRICE			SIZE / INCHES			WEIGHT VOL	
	GR 1	GR 2	OPT*	H	W	D	LBS	FT <sup>3</sup>
BPX3TPV4230	787	825	868	42	30	2.61	22.3	3.382
BPX3TPV4236	859	898	940	42	36	2.61	24.5	4.081
BPX3TPV4242	938	977	1020	42	42	2.61	26.7	4.758
BPX3TPV4248	1011	1049	1092	42	48	2.61	30.8	5.426
BPX3TPV4254	1090	1128	1171	42	54	2.61	33.0	6.135
BPX3TPV4260	1172	1211	1253	42	60	2.61	35.2	6.852
BPX3TPV4266	1235	1313	1400	42	66	2.61	42.4	7.556
BPX3TPV4272	1297	1376	-	42	72	2.61	48.6	8.260
BPX3TPV5030	787	825	868	50	30	2.61	23.3	3.960
BPX3TPV5036	859	898	940	50	36	2.61	25.5	4.732
BPX3TPV5042	938	977	1020	50	42	2.61	27.7	5.484
BPX3TPV5048	1011	1049	1092	50	48	2.61	30.8	6.226
BPX3TPV5054	1090	1128	1171	50	54	2.61	34.0	7.008
BPX3TPV5060	1172	1211	1253	50	60	2.61	36.2	7.790
BPX3TPV5066	1235	1313	1400	50	66	2.61	43.4	8.675
BPX3TPV5072	1297	1376	-	50	72	2.61	50.6	9.560
BPX3TPV6630	935	976	1016	66	30	2.61	28.3	4.997
BPX3TPV6636	1024	1064	1105	66	36	2.61	30.5	5.964
BPX3TPV6642	1108	1149	1189	66	42	2.61	32.7	6.910
BPX3TPV6648	1194	1236	1277	66	48	2.61	36.8	7.847
BPX3TPV6654	1289	1329	1370	66	54	2.61	40.0	8.823
BPX3TPV6660	1377	1418	1458	66	60	2.61	43.2	9.799

**BPX3TPF • Pass-Thru Panel With Embedded Felt Divider - Air Flow Base**

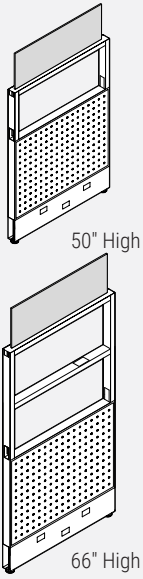

- Allows air to flow freely through the bottom of the panel.
- B3 panel top trim option provided with embedded, frameless felt panel rising 8" or 16" above the top of the panel. For instance, when installed on 42" high B3 panel, overall height will be 50" high for 8" and 58" high for 16".
- There is 1.25" gap between two adjacent felt panels.
- Felt panel shipped separately.
- 9 mm Felt material is tackable and comes in 18 different colors. Please specify color.
- NOTE: List price shown is for 8" high felt only.

PRODUCT CODE	PRICE	SIZE / INCHES			WEIGHT VOL	
		H	W	D	LBS	FT <sup>3</sup>
BPX3TPF5018	783	50	18	2.61	17.9	2.396
BPX3TPF5024	889	50	24	2.61	20.1	3.178
BPX3TPF5030	993	50	30	2.61	23.3	3.960
BPX3TPF5036	1107	50	36	2.61	25.5	4.732
BPX3TPF5042	1219	50	42	2.61	26.7	5.484
BPX3TPF5048	1328	50	48	2.61	30.8	6.226
BPX3TPF5054	1446	50	54	2.61	33.0	7.008
BPX3TPF5060	1553	50	60	2.61	36.2	7.790
BPX3TPF6618	905	66	18	2.61	21.9	3.045
BPX3TPF6624	1022	66	24	2.61	25.1	4.021
BPX3TPF6630	1151	66	30	2.61	28.3	4.997
BPX3TPF6636	1275	66	36	2.61	30.5	5.964
BPX3TPF6642	1404	66	42	2.61	32.7	6.910
BPX3TPF6648	1529	66	48	2.61	36.8	7.847
BPX3TPF6654	1662	66	54	2.61	40.0	8.823
BPX3TPF6660	1788	66	60	2.61	42.2	9.799

**BPX3TOP • Over Panel Frame With Embedded Felt Divider**

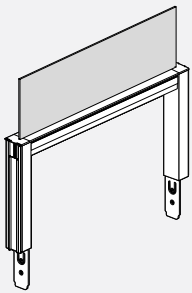

- Attaches to the top of any Boulevard System 3 panel to create a floor-to-ceiling wall
- B3 panel top trim option provided with embedded, frameless felt panel rising 8" or 16" above the top of the panel. For instance, when installed on 42" high B3 panel, overall height will be 50" high for 8" and 58" high for 16".
- There is 1.25" gap between two adjacent felt panels.
- Felt panel shipped separately.
- 9 mm Felt material is tackable and comes in 18 different colors. Please specify color.

PRODUCT CODE	PRICE	SIZE / INCHES			WEIGHT VOL	
		H	W	D	LBS	FT <sup>3</sup>
BPX3TOP0818	190	8	18	2.61	3.9	0.673
BPX3TOP0824	211	8	24	2.61	6.1	0.878
BPX3TOP0830	233	8	30	2.61	7.3	1.246
BPX3TOP0836	258	8	36	2.61	7.5	1.442
BPX3TOP0842	285	8	42	2.61	8.7	1.725
BPX3TOP0848	308	8	48	2.61	9.8	1.890
BPX3TOP0854	340	8	54	2.61	11.0	2.150
BPX3TOP0860	365	8	60	2.61	11.2	2.464
BPX3TOP0866	401	8	66	2.61	13.4	2.722
BPX3TOP0872	433	8	72	2.61	14.6	2.980
BPX3TOP1618	190	16	18	2.61	4.9	0.928
BPX3TOP1624	211	16	24	2.61	7.1	1.170
BPX3TOP1630	233	16	30	2.61	8.3	1.684
BPX3TOP1636	258	16	36	2.61	8.5	1.916
BPX3TOP1642	285	16	42	2.61	9.7	2.309
BPX3TOP1648	308	16	48	2.61	10.8	2.510
BPX3TOP1654	340	16	54	2.61	12.0	2.843
BPX3TOP1660	365	16	60	2.61	12.2	3.266
BPX3TOP1666	401	16	66	2.61	14.4	3.598
BPX3TOP1672	433	16	72	2.61	16.6	3.930

**BP3DS • Solid Door Panel**

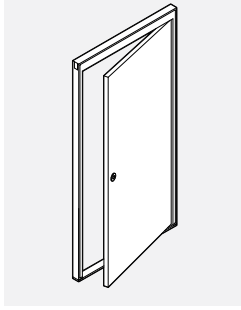

- Aluminum frame with either high pressure laminate door.
- 1 3/8" thick hollow core door.
- Actual door size:
  - 79.9" x 32 1/2" in 82" x 36" frame
  - 79.9" x 38 1/2" in 82" x 42" frame
- 42" wide Door Panel permits wheelchair accessibility.
- No hang-on capabilities.
- 180 degree swing.
- Specify Door Knob (DL01) or Door Lever (DL02).
- Lock standard.
- Handedness can be changed on site.
- Please specify Right hand (R) or Left hand (L) hung.
- Includes a Horizontal Lay-in Channel.

PRODUCT CODE	PRICE HP	SIZE/INCHES			WEIGHT VOL	
		H	W	D	LBS	FT <sup>3</sup>
BP3DS8236R	2078	82	36	2.61	61	6.465
BP3DS8242R	2263	82	42	2.61	68	7.486
BP3DS8236L	2078	82	36	2.61	61	6.465
BP3DS8242L	2263	82	42	2.61	68	7.486

**Door Hanging Directions**



Right Shown



Left Shown

**Door Handle Option**

Door Knob - DL01  
• Lock Standard



Door Lever - DL02 (Default)  
Lock Standard

Lever complies with all accessibility standards



**BP3DH • Half-Glazed Door Panel**

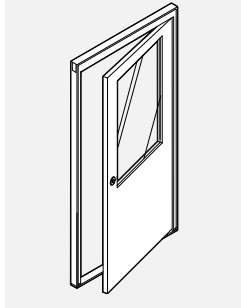

- Aluminum frame with either high pressure laminate door and window.
- 1 3/8" thick hollow core door.
- Actual door size:
  - 79.9" x 32 1/2" in 82" x 36" frame
  - 79.9" x 38 1/2" in 82" x 42" frame
- 42" wide Door Panel permits wheelchair accessibility.
- No hang-on capabilities.
- 180 degree swing.
- Specify Door Knob (DL01) or Door Lever (DL02).
- Lock standard.
- Handedness can be changed on site.
- Please specify Right hand (R) or Left hand (L) hung.
- Includes a Horizontal Lay-in Channel.

PRODUCT CODE	PRICE HP	SIZE/INCHES			WEIGHT VOL	
		H	W	D	LBS	FT <sup>3</sup>
BP3DH8236R	2573	82	36	2.61	53	6.465
BP3DH8242R	2814	82	42	2.61	59	7.486
BP3DH8236L	2573	82	36	2.61	53	6.465
BP3DH8242L	2814	82	42	2.61	59	7.486

**Door Hanging Directions**



Right Shown



Left Shown

**Door Handle Option**

Door Knob - DL01  
• Lock Standard



Door Lever - DL02 (Default)  
Lock Standard

Lever complies with all accessibility standards



**BP3DG • Full-Glazed Door Panel**

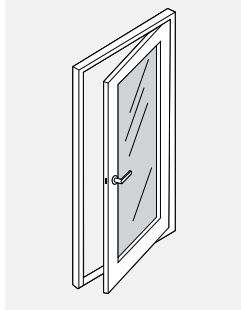

- Aluminum frame with either high pressure laminate door and window.
- 1 3/8" thick hollow core door.
- Actual door size:
  - 79.9" x 32 1/2" in 82" x 36" frame
  - 79.9" x 38 1/2" in 82" x 42" frame
- 42" wide Door Panel permits wheelchair accessibility.
- No hang-on capabilities.
- 180 degree swing.
- Specify Door Knob (DL01) or Door Lever (DL02).
- Lock standard.
- Handedness can be changed on site.
- Please specify Right hand (R) or Left hand (L) hung.
- Includes a Horizontal Lay-in Channel.
- Laminate frame is 5" thick at the sides and 4" at the top and bottom.

PRODUCT CODE	PRICE HP	SIZE/INCHES			WEIGHT VOL	
		H	W	D	LBS	FT <sup>3</sup>
BP3DG8236R	4120	82	36	2.61	53	6.465
BP3DG8242R	4507	82	42	2.61	59	7.486
BP3DG8236L	4120	82	36	2.61	53	6.465
BP3DG8242L	4507	82	42	2.61	59	7.486

**Door Hanging Directions**

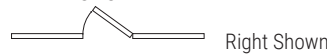

Right Shown



Left Shown

**Door Handle Option**

Door Knob - DL01  
• Lock Standard



Door Lever - DL02 (Default)  
Lock Standard

Lever complies with all accessibility standards



**BPX3NET • Removable Face Tile - Electrical Tile Kit**

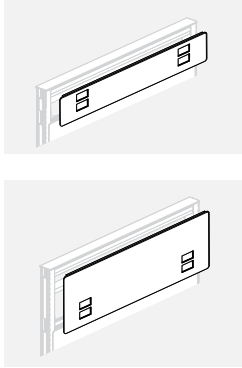

- Attaches to an 8" or 16" opening in a Pass-Thru Panel.
- Fabric covered tile with knock-out for power and data. (Data/Comm blank covers included).
- 24" wide tiles have one duplex and one data/comm opening. 30" and wider tiles have two duplex and two data/comm openings.
- Easily interchangeable on site.
- Provides access to electrical and data at a required location.
- Specify Tile Electrical Kit separately.
- Duplexes and covers must be specified separately.
- For power outlets on both sides of the panel, specify two Electrical Tiles per panel. For power outlets on one side only, specify one Electrical Tile and a Fabric Tile for the opposite side.
- OPT\* = Laminate or Whiteboard.
- For use on panels manufactured after November 1, 2014

PRODUCT CODE	PRICE			SIZE/INCHES			WEIGHT VOL	
	GR1	GR2	OPT*	H	W	D	LBS	FT <sup>3</sup>
BPX3NET0824	118	124	130	8	24	0.125	2.0	0.170
BPX3NET0830	188	201	215	8	30	0.125	2.5	0.200
BPX3NET0836	211	222	237	8	36	0.125	2.5	0.250
BPX3NET0842	218	230	247	8	42	0.125	2.5	0.292
BPX3NET0848	223	236	252	8	48	0.125	3.0	0.333
BPX3NET0854	231	245	259	8	54	0.125	3.0	0.375
BPX3NET0860	237	250	264	8	60	0.125	4.5	0.417
BPX3NET0866	339	392	448	8	66	0.125	4.7	0.475
BPX3NET0872	438	492	-	8	72	0.125	5.0	0.500
BPX3NET1624	118	124	130	16	24	0.125	2.5	3.400
BPX3NET1630	188	201	215	16	30	0.125	3.0	0.416
BPX3NET1636	211	222	237	16	36	0.125	3.0	0.500
BPX3NET1642	218	230	247	16	42	0.125	3.0	0.583
BPX3NET1648	223	236	252	16	48	0.125	4.0	0.666
BPX3NET1654	231	245	259	16	54	0.125	4.0	0.750
BPX3NET1660	237	250	264	16	60	0.125	5.0	0.833
BPX3NET1666	339	392	448	16	66	0.125	5.5	0.911
BPX3NET1672	438	492	-	16	72	0.125	6.0	1.000

**BP3GT • Removable Face Tile - Glazed**

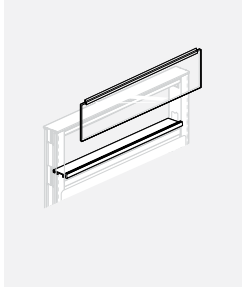

- Attaches to any opening in a Pass-Thru Panel.
- 8" or 16" high glazing provides visual accessibility and light transfer.
- Easily interchangeable on site.
- Specify one Glazed Tile for panel opening of corresponding width.
- Clear tempered glass standard.

PRODUCT CODE	PRICE	FRST	SIZE/INCHES			WEIGHT VOL	
			H	W	D	LBS	FT <sup>3</sup>
BP3GT0818	72	98	8	18	2.61	2.3	0.146
BP3GT0824	96	123	8	24	2.61	3.1	0.165
BP3GT0830	122	149	8	30	2.61	3.9	0.200
BP3GT0836	149	174	8	36	2.61	4.7	0.250
BP3GT0842	172	200	8	42	2.61	5.5	0.292
BP3GT0848	200	225	8	48	2.61	6.3	0.333
BP3GT0854	222	250	8	54	2.61	7.1	0.375
BP3GT0860	250	276	8	60	2.61	7.8	0.417
BP3GT0866	356	383	8	66	2.61	8.6	0.460
BP3GT0872	464	490	8	72	2.61	9.4	0.500
BP3GT1618	72	98	16	18	2.61	4.3	0.292
BP3GT1624	96	123	16	24	2.61	5.8	0.333
BP3GT1630	122	149	16	30	2.61	7.2	0.416
BP3GT1636	149	174	16	36	2.61	8.7	0.500
BP3GT1642	172	200	16	42	2.61	10.2	0.583
BP3GT1648	200	225	16	48	2.61	11.6	0.666
BP3GT1654	222	250	16	54	2.61	13.1	0.750
BP3GT1660	250	276	16	60	2.61	14.6	0.833
BP3GT1666	356	383	16	66	2.61	16.0	0.911
BP3GT1672	464	490	16	72	2.61	17.5	1.000

**BPX3ETCS Removable Face Tile - Chicago Electrical Tile Kit - Single Punch**

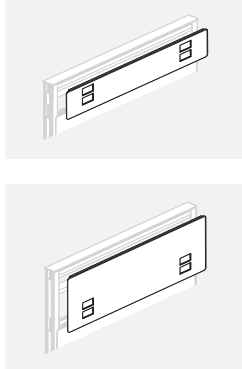

- Attaches to an 8" or 16" opening in Pass-Thru panel.
- Fabric covered tile with single knock-out for power.
- Easily interchangeable on site.
- Provides access to electrical and data at a required location.
- Specify Chicago Electrical Kit separately.
- Duplexes and covers must be specified separately.
- OPT\* = Laminate or Whiteboard.
- For use on Panels manufactured after November 1, 2014.

PRODUCT CODE	PRICE			SIZE/INCHES			WEIGHT VOL	
	GR1	GR2	OPT*	H	W	D	LBS	FT <sup>3</sup>
BPX3ETCS0824	125	133	139	8	24	0.125	2	0.170
BPX3ETCS0830	203	214	230	8	30	0.125	2.5	0.200
BPX3ETCS0836	225	238	253	8	36	0.125	2.5	0.250
BPX3ETCS0842	234	247	263	8	42	0.125	2.5	0.292
BPX3ETCS0848	239	252	268	8	48	0.125	3	0.333
BPX3ETCS0854	248	261	277	8	54	0.125	3	0.375
BPX3ETCS0860	253	266	282	8	60	0.125	4.5	0.417
BPX3ETCS0866	362	419	477	8	66	0.125	4.7	0.475
BPX3ETCS0872	469	525	585	8	72	0.125	5	0.500
BPX3ETCS1624	125	133	139	16	24	0.125	2	0.400
BPX3ETCS1630	203	214	230	16	30	0.125	2.5	0.416
BPX3ETCS1636	225	238	253	16	36	0.125	2.5	0.500
BPX3ETCS1642	234	247	263	16	42	0.125	2.5	0.583
BPX3ETCS1648	239	252	268	16	48	0.125	3	0.666
BPX3ETCS1654	248	261	277	16	54	0.125	3	0.750
BPX3ETCS1660	253	266	282	16	60	0.125	4.5	0.833
BPX3ETCS1666	362	419	477	16	66	0.125	4.7	0.911
BPX3ETCS1672	469	525	585	16	72	0.125	5	1.000



**BPX3ETCS Removable Face Tile - Chicago Electrical Tile Kit - Double Punch**

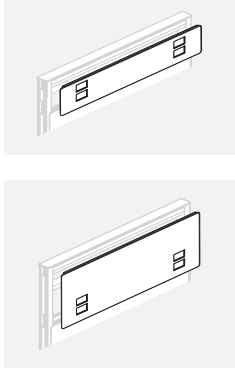

- Attaches to an 8" or 16" opening in Pass-Thru panel.
- Fabric covered tile with double knock-out for power.
- Easily interchangeable on site.
- Provides access to electrical and data at a required location.
- Specify Chicago Electrical Kit separately.
- Duplexes and covers must be specified separately.
- OPT\* = Laminate or Whiteboard.
- For use on Panels manufactured after November 1, 2014.

PRODUCT CODE	PRICE			SIZE/INCHES			WEIGHT VOL	
	GR 1	GR 2	OPT*	H	W	D	LBS	FT <sup>3</sup>
BPX3ETCD0824	136	144	152	8	24	0.125	2	0.170
BPX3ETCD0830	220	234	250	8	30	0.125	2.5	0.200
BPX3ETCD0836	245	259	276	8	36	0.125	2.5	0.250
BPX3ETCD0842	255	268	287	8	42	0.125	2.5	0.292
BPX3ETCD0848	260	275	293	8	48	0.125	3	0.333
BPX3ETCD0854	270	286	302	8	54	0.125	3	0.375
BPX3ETCD0860	276	291	308	8	60	0.125	4.5	0.417
BPX3ETCD0866	394	457	522	8	66	0.125	4.7	0.475
BPX3ETCD0872	511	574	638	8	72	0.125	5	0.500
BPX3ETCD1624	136	144	152	16	24	0.125	2	0.400
BPX3ETCD1630	220	234	250	16	30	0.125	2.5	0.416
BPX3ETCD1636	245	259	276	16	36	0.125	2.5	0.500
BPX3ETCD1642	255	268	287	16	42	0.125	2.5	0.583
BPX3ETCD1648	260	275	293	16	48	0.125	3	0.666
BPX3ETCD1654	270	286	302	16	54	0.125	3	0.750
BPX3ETCD1660	276	291	308	16	60	0.125	4.5	0.833
BPX3ETCD1666	394	457	522	16	66	0.125	4.7	0.911
BPX3ETCD1672	511	574	638	16	72	0.125	5	1.000

**BP3DGT • Removable Face Tile - Double Glazed**

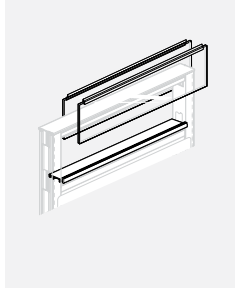

- Attaches to any opening in a Pass-Thru Panel.
- 8" or 16" high glazing provides visual accessibility and light transfer.
- Easily interchangeable on site.
- Specify one Double Glazed Tile for panel opening of corresponding width.
- Clear tempered glass standard.

PRODUCT CODE	PRICE	FRST	SIZE/INCHES			WEIGHT VOL	
			H	W	D	LBS	FT <sup>3</sup>
BP3DGT0818	182	216	8	18	2.61	6.0	0.292
BP3DGT0824	243	288	8	24	2.61	8.2	0.330
BP3DGT0830	307	365	8	30	2.61	10.4	0.400
BP3DGT0836	376	448	8	36	2.61	12.6	0.500
BP3DGT0842	436	523	8	42	2.61	14.7	0.584
BP3DGT0848	501	603	8	48	2.61	16.9	0.666
BP3DGT0854	565	679	8	54	2.61	19.0	0.750
BP3DGT0860	630	755	8	60	2.61	21.3	0.834
BP3DGT0866	693	831	8	66	2.61	23.4	0.920
BP3DGT0872	755	907	8	72	2.61	25.6	1.000
BP3DGT1618	212	254	16	18	2.61	10.0	0.584
BP3DGT1624	285	341	16	24	2.61	13.6	0.666
BP3DGT1630	361	432	16	30	2.61	17.1	0.832
BP3DGT1636	439	528	16	36	2.61	20.6	1.000
BP3DGT1642	512	615	16	42	2.61	24.1	1.166
BP3DGT1648	588	706	16	48	2.61	27.7	1.322
BP3DGT1654	664	797	16	54	2.61	31.2	1.500
BP3DGT1660	740	887	16	60	2.61	34.7	1.666
BP3DGT1666	815	937	16	66	2.61	38.2	1.822
BP3DGT1672	887	1020	16	72	2.61	41.7	2.000

**BP30T • Removable Face Tile - Open Pass-Thru Kit**

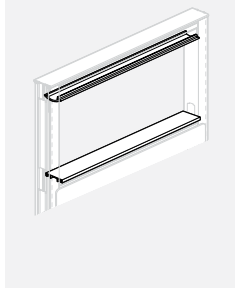

- Attaches to any opening in a Pass-Thru Panel.
- Trims and internal corners included to create an opening.
- Easily interchangeable on site.
- Specify one Pass-Thru Kit for panel opening of corresponding width.
- Kit works for 8" & 16" openings.
- Please specify panel frame color.

PRODUCT CODE	PRICE	SIZE/INCHES			WEIGHT VOL	
		H	W	D	LBS	FT <sup>3</sup>
BP30T1618	10	16	18	2.61	0.4	0.292
BP30T1624	12	16	24	2.61	0.6	0.333
BP30T1630	15	16	30	2.61	0.8	0.416
BP30T1636	25	16	36	2.61	1.0	0.500
BP30T1642	28	16	42	2.61	1.1	0.583
BP30T1648	32	16	48	2.61	1.3	0.666
BP30T1654	34	16	54	2.61	1.5	0.750
BP30T1660	38	16	60	2.61	1.7	0.833
BP30T1666	53	16	66	2.61	1.9	0.911
BP30T1672	70	16	72	2.61	2.0	1.000

**BP3AT • Removable Face Tile - Accessory**

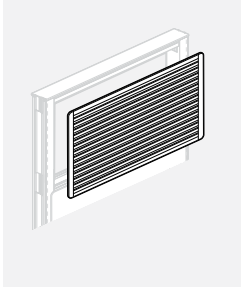

- Attaches to any opening in a Pass-Thru Panel.
- Provides support for accessories.
- Easily interchangeable on site.
- Two tile clips included.
- Specify two tiles per panel opening of corresponding width. Tiles can be combined. For example, Fabric Tile on one side and Accessory Tile on the opposite side of the same panel.
- Accessory Tile cannot be installed opposite an electrical tile.

PRODUCT CODE	PRICE	SIZE / INCHES			WEIGHT VOL	
		H	W	D	LBS	FT <sup>3</sup>
BP3AT0818	97	08	18	0.25	1.7	0.146
BP3AT0824	117	08	24	0.25	2.3	0.167
BP3AT0830	125	08	30	0.25	2.9	0.208
BP3AT0836	151	08	36	0.25	3.5	0.250
BP3AT0842	178	08	42	0.25	4.1	0.292
BP3AT0848	207	08	48	0.25	4.7	0.333
BP3AT0854	226	08	54	0.25	5.3	0.375
BP3AT0860	255	08	60	0.25	5.9	0.417
BP3AT0866	366	08	66	0.25	6.5	0.459
BP3AT0872	476	08	72	0.25	7.0	0.500
BP3AT1618	97	16	18	0.25	3.5	0.292
BP3AT1624	117	16	24	0.25	4.7	0.333
BP3AT1630	125	16	30	0.25	5.7	0.416
BP3AT1636	151	16	36	0.25	7.0	0.500
BP3AT1642	178	16	42	0.25	8.2	0.583
BP3AT1648	207	16	48	0.25	9.4	0.666
BP3AT1654	226	16	54	0.25	10.6	0.750
BP3AT1660	255	16	60	0.25	11.9	0.833
BP3AT1666	366	16	66	0.25	13.0	0.916
BP3AT1672	476	16	72	0.25	14.0	1.000

**BP3FT • Removable Face Tile - Fabric**

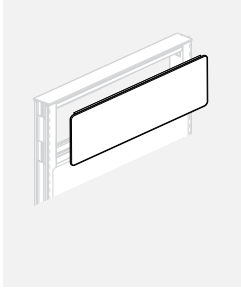

- Attaches to any opening in a Pass-Thru Panel.
- Tile clips included.
- Easily interchangeable on site.
- Specify two tiles per panel opening of corresponding width. Tiles can be combined. For example, Fabric Tile on one side and Accessory Tile on the opposite side of the same panel.
- OPT\* = Laminate or Whiteboard.

PRODUCT CODE	PRICE			SIZE / INCHES			WEIGHT VOL	
	GR1	GR2	OPT*	H	W	D	LBS	FT <sup>3</sup>
BP3FT0818	87	93	101	8	18	0.25	1	0.146
BP3FT0824	93	99	108	8	24	0.25	1	0.165
BP3FT0830	99	113	125	8	30	0.25	2	0.200
BP3FT0836	122	134	150	8	36	0.25	2	0.250
BP3FT0842	130	144	158	8	42	0.25	2	0.292
BP3FT0848	136	150	163	8	48	0.25	3	0.333
BP3FT0854	144	156	169	8	54	0.25	3	0.375
BP3FT0860	150	161	174	8	60	0.25	4	0.417
BP3FT0866	227	281	338	8	66	0.25	4	0.460
BP3FT0872	307	361	-	8	72	0.25	4	0.500
BP3FT1618	87	93	101	16	18	0.25	2	0.292
BP3FT1624	93	99	108	16	24	0.25	2	0.333
BP3FT1630	99	113	125	16	30	0.25	3	0.416
BP3FT1636	122	134	150	16	36	0.25	3	0.500
BP3FT1642	130	144	158	16	42	0.25	3	0.583
BP3FT1648	136	150	163	16	48	0.25	4	0.666
BP3FT1654	144	156	169	16	54	0.25	4	0.750
BP3FT1660	150	161	174	16	60	0.25	5	0.833
BP3FT1666	227	281	338	16	66	0.25	5	0.920
BP3FT1672	307	361	-	16	72	0.25	6	1.000

**BP3OPFA • Fabric Over Panel**

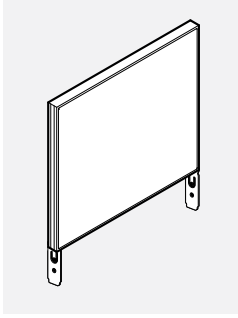

- Attaches to top of a panel to create floor-to-ceiling wall.
- Center septum overlaid on either side with 1 1/8" Sound absorbent mineral board."
- Non-slotted.
- Exact height should be specified when ordering, with allowance of at least 1" of free space between over panel and ceiling to accommodate height variations in ceiling and floor. Can be any height from 4.4" minimum to 15.9" maximum. Please tag exact height required.
- Runs of over panels should be captured at either end with full height posts, wall adapters, taller panels, and/or vertical trims.
- OPT\* = Laminate or Whiteboard.

PRODUCT CODE	PRICE			SIZE/INCHES			WEIGHT VOL	
	GR1	GR2	OPT*	H	W	D	LBS	FT <sup>3</sup>
BP3OPFA18XX	215	227	243	16	18	2.61	8	0.730
BP3OPFA24XX	244	254	269	16	24	2.61	8	0.730
BP3OPFA30XX	280	291	307	16	30	2.61	10	0.912
BP3OPFA36XX	314	328	341	16	36	2.61	12	1.094
BP3OPFA42XX	342	356	371	16	42	2.61	12	1.094
BP3OPFA48XX	379	394	406	16	48	2.61	14	1.277
BP3OPFA54XX	416	426	441	16	54	2.61	14	1.277
BP3OPFA60XX	441	452	469	16	60	2.61	15	1.368

**BP3OPFV • Fabric Over Panel With Vertical Wire Channel**

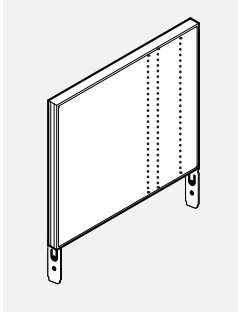

- Attaches to top of a panel to create floor-to-ceiling wall.
- Center septum overlaid on either side with 1" sound absorbent mineral board.
- Non-slotted.
- Exact height should be specified when ordering, with allowance of at least 1" of free space between over panel and ceiling to accommodate height variations in ceiling and floor. Can be any height from 4.4" minimum to 15.9" maximum. Please tag exact height required.
- Runs of over panels should be captured at either end with full height posts, wall adapters, taller panels, and/or vertical trims.
- OPT\* = Laminate or Whiteboard.

PRODUCT CODE	PRICE			SIZE/INCHES			WEIGHT VOL	
	GR1	GR2	OPT*	H	W	D	LBS	FT <sup>3</sup>
BP3OPFV18XX	254	266	280	16	18	2.61	8	0.73
BP3OPFV24XX	281	303	308	16	24	2.61	8	0.73
BP3OPFV30XX	319	330	345	16	30	2.61	10	0.912
BP3OPFV36XX	355	366	382	16	36	2.61	12	1.094
BP3OPFV42XX	382	394	409	16	42	2.61	12	1.094
BP3OPFV48XX	419	431	444	16	48	2.61	14	1.277
BP3OPFV54XX	452	466	479	16	54	2.61	14	1.277
BP3OPFV60XX	480	491	508	16	60	2.61	15	1.368

**BA3PAS • Glass Over Panel With Round Pucks for System 3**

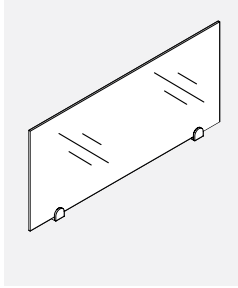

- Glass Over Panel creates division.
- Glass Over Panel with no frame sits on top of a System 3 Panel with clamps that are secured to the top of the panel.
- Tempered glass is 16" high.
- Custom sizes available, contact your Customer Service Representative.
- For application where the over panel is sandwiched between two taller panels, please request a special as the glass will not fit due to trims.

PRODUCT CODE	PRICE		FRST	SIZE/ INCHES			WEIGHT VOL	
	CLR	FRST		H	W	D	LBS	FT <sup>3</sup>
BA3PAS0824	212	234	8	24	1.3	4	0.22	
BA3PAS0830	231	259	8	30	1.3	5	0.30	
BA3PAS0836	249	279	8	36	1.3	6	0.37	
BA3PAS0842	263	299	8	42	1.3	7	0.43	
BA3PAS0848	271	317	8	48	1.3	8	0.48	
BA3PAS1624	212	234	16	24	1.3	8	0.44	
BA3PAS1630	231	259	16	30	1.3	10	0.59	
BA3PAS1636	249	279	16	36	1.3	12	0.73	
BA3PAS1642	263	299	16	42	1.3	14	0.85	
BA3PAS1648	271	317	16	48	1.3	16	0.96	

**BA3PASS • Glass Over Panel With Square Pucks for System 3**

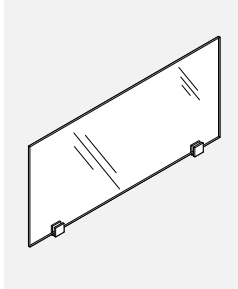

- Glass Over Panel creates division.
- Glass Over Panel with no frame sits on top of a System 3 Panel with clamps that are secured to the top of the panel.
- Tempered glass is 16" high.
- Custom sizes available, contact your Customer Service Representative.
- For application where the over panel is sandwiched between two taller panels, please request a special as the glass will not fit due to trims.

PRODUCT CODE	PRICE		FRST	SIZE/ INCHES			WEIGHT VOL	
	CLR	FRST		H	W	D	LBS	FT <sup>3</sup>
BA3PASS0824	216	238	8	24	1.3	4	0.22	
BA3PASS0830	237	263	8	30	1.3	5	0.30	
BA3PASS0836	253	284	8	36	1.3	6	0.37	
BA3PASS0842	268	304	8	42	1.3	7	0.43	
BA3PASS0848	277	320	8	48	1.3	8	0.48	
BA3PASS1624	216	238	16	24	1.3	8	0.44	
BA3PASS1630	237	263	16	30	1.3	10	0.59	
BA3PASS1636	253	284	16	36	1.3	12	0.73	
BA3PASS1642	268	304	16	42	1.3	14	0.85	
BA3PASS1648	277	320	16	48	1.3	16	0.96	

**BPMB • Raceway Cover Caps**



- To provide clean detail for the punch-outs of a raceway cover when the punch-outs are not in use. Order only when required.
- Made of injection molded ABS.
- B = Black
- G = Grey
- W = White

PRODUCT CODE	PRICE	SIZE/INCHES			WEIGHT VOL	
		H	W	D	LBS	FT <sup>3</sup>
BPMB020104B	10	1.5	3	0.125	0.04	0.02
BPMB020104G	10	1.5	3	0.125	0.04	0.02
BPMB020104W	10	1.5	3	0.125	0.04	0.02

**BH3PS • 90 Degree Post**



- Enables connection for multiple panel runs such as 90°, 3 way and 4 way.
- Includes 2 "Capture Strip" panel connectors, 4 end strips, 2 pairs of raceway end caps, and 1 post cap.
- Posts are designed to accept the following:
  - 75 cables 5.6 mm (0.220") diameter
  - 60 cables 5.6 mm (0.220") diameter with 1 power feed
  - 45 cables 5.6 mm (0.220") diameter with 2 power feeds

PRODUCT CODE	PRICE	SIZE/INCHES			WEIGHT VOL	
		H	W	D	LBS	FT <sup>3</sup>
BH3PS034	69	27	2.61	2.61	4	0.14
BH3PS042	104	35	2.61	2.61	5	0.18
BH3PS050	119	43	2.61	2.61	7	0.22
BH3PS054	131	47	2.61	2.61	7	0.27
BH3PS058	137	51	2.61	2.61	8	0.29
BH3PS066	145	59	2.61	2.61	8	0.31

**BH3PS45 • 45 Degree Post**



- Enables connection for two panels at 45°.
- Includes 2 "Capture Strip" panel connectors and 1 post cap.
- 45 degree post does not accept End Trim.
- No power infeed capabilities.
- Posts are designed to accept the following:
  - 30 cables 5.6 mm (0.220") diameter

PRODUCT CODE	PRICE	SIZE/INCHES			WEIGHT VOL	
		H	W	D	LBS	FT <sup>3</sup>
BH3PS45034	69	27	2.61	2.61	4	0.14
BH3PS45042	104	35	2.61	2.61	5	0.18
BH3PS45050	119	43	2.61	2.61	7	0.22
BH3PS45054	131	47	2.61	2.61	7	0.27
BH3PS45058	140	51	2.61	2.61	8	0.29
BH3PS45066	149	59	2.61	2.61	8	0.31

**BH3PS60 • 60 Degree Post**



- Enables connection for multiple panel runs such as 120° and 3 way.
- Includes 2 "Capture Strip" panel connectors and 1 post cap.
- No power infeed capabilities.
- Posts are designed to accept the following:
  - 35 cables 5.6 mm (0.220") diameter

PRODUCT CODE	PRICE	SIZE/INCHES			WEIGHT VOL	
		H	W	D	LBS	FT <sup>3</sup>
BH3PS60034	69	27	2.61	2.61	4	0.14
BH3PS60042	104	35	2.61	2.61	5	0.18
BH3PS60050	119	43	2.61	2.61	7	0.22
BH3PS60054	131	47	2.61	2.61	7	0.27
BH3PS60058	140	51	2.61	2.61	8	0.29
BH3PS60066	149	59	2.61	2.61	8	0.31

**BH3PE • Post Extension for Over Panels**



- Provides route for ceiling data or electrical cables through the post to the panel.
- Includes 2 "Capture Strip" panel connectors.

PRODUCT CODE	PRICE	SIZE/INCHES			WEIGHT VOL	
		H	W	D	LBS	FT <sup>3</sup>
BH3PE008	32	8	2.61	2.61	1	0.03
BH3PE016	39	16	2.61	2.61	2	0.07
BH3PE032	69	32	2.61	2.61	4	0.14
BH3PE45016	39	16	2.61	2.61	2	0.07
BH3PE45032	69	32	2.61	2.61	4	0.14
BH3PE60016	39	16	2.61	2.61	2	0.07
BH3PE60032	70	32	2.61	2.61	4	0.14

**BH3PA • Off-Module Connector (Panel-to-Panel Adapter)**

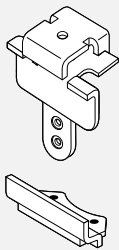

- Connects Boulevard System 3 panel to another perpendicular Boulevard System 3 Monolithic Panel off-module.
- Top and bottom brackets bolt to panel vertical of one panel and engage to top and bottom "fabric" edges of adjacent, perpendicular Monolithic Panel of even height.
- While connecting tile panel to Monolithic Panel is possible, never attempt to secure Off-Module Connectors to a tile panel.
- Once an off-module panel is secure to Monolithic Panel spine with Off-Module Connecting Kit, the raceway on the spine panel cannot be accessed and can only be opened from the opposite side.
- Special top trim required, provide application to your Customer Service Representative.
- This connector is not a load-bearing connection.
- Not to be used on the panel seam, with over panels or laminate and metal faced panels.

PRODUCT CODE	PRICE	SIZE/INCHES			WEIGHT VOL	
		H	W	D	LBS	FT <sup>3</sup>
BH3PA02	77	3.5			0.5	0.035

**RCX3WMP2 • Raceway Cover With Punch-Outs Both Sides**

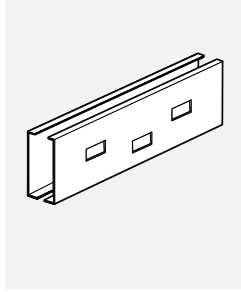

- Metal raceway organizes cables at the base.
- Snaps directly into the base of the panel.
- When opened, cover's side rests on the floor, providing unobstructed access to data/power installation.
- 18" Raceway Covers do not have power and data/communication punch-outs.
- 24" Raceway covers have electrical and one data opening.
- Data opening sizing is as follows: 1.38" x 2.71".
- Comes standard with all System 3 panels.
- "No Knockouts" option for raceways available at no additional charge. Please choose option for interior and/or exterior raceways.

PRODUCT CODE	PRICE	SIZE/INCHES			WEIGHT VOL	
		H	W	D	LBS	FT <sup>3</sup>
RCX3WM24P2	53	5.62	24	2.61	3.3	0.21
RCX3WM30P2	64	5.62	30	2.61	4.1	0.26
RCX3WM36P2	71	5.62	36	2.61	4.9	0.31
RCX3WM42P2	77	5.62	42	2.61	5.7	0.36
RCX3WM48P2	85	5.62	48	2.61	6.6	0.42
RCX3WM54P2	93	5.62	54	2.61	7.4	0.47
RCX3WM60P2	101	5.62	60	2.61	8.3	0.52
RCX3WM66P2	158	5.62	66	2.61	9.1	0.57
RCX3WM72P2	166	5.62	72	2.61	9.8	0.62

**RCX3WMP1 • Raceway Cover With Punch-Outs One Side, None Other Side**

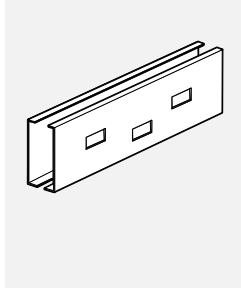

- Metal raceway organizes cables at the base.
- Snaps directly into the base of the panel.
- When opened, cover's side rests on the floor, providing unobstructed access to data/power installation.
- 18" Raceway Covers do not have power and data/communication punch-outs.
- 24" Raceway covers have electrical and one data opening.
- Data opening sizing is as follows: 1.38" x 2.71".
- Comes standard with all System 3 panels.
- "No Knockouts" option for raceways available at no additional charge. Please choose option for interior and/or exterior raceways.

PRODUCT CODE	PRICE	SIZE/INCHES			WEIGHT VOL	
		H	W	D	LBS	FT <sup>3</sup>
RCX3WM24P1	53	5.62	24	2.61	3.3	0.21
RCX3WM30P1	64	5.62	30	2.61	4.1	0.26
RCX3WM36P1	71	5.62	36	2.61	4.9	0.31
RCX3WM42P1	77	5.62	42	2.61	5.7	0.36
RCX3WM48P1	85	5.62	48	2.61	6.6	0.42
RCX3WM54P1	93	5.62	54	2.61	7.4	0.47
RCX3WM60P1	101	5.62	60	2.61	8.3	0.52
RCX3WM66P1	158	5.62	66	2.61	9.1	0.57
RCX3WM72P1	166	5.62	72	2.61	9.8	0.62

**RCX3WMNP • Raceway Cover With No Punch-Outs Both Sides**

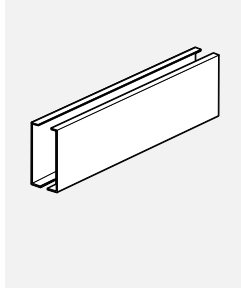

- Metal raceway organizes cables at the base.
- Snaps directly into the base of the panel.
- When opened, cover's side rests on the floor, providing unobstructed access to data/power installation.

PRODUCT CODE	PRICE	SIZE/INCHES			WEIGHT VOL	
		H	W	D	LBS	FT <sup>3</sup>
RCX3WM18NP	45	5.62	18	2.61	2.4	0.16
RCX3WM24NP	53	5.62	24	2.61	3.3	0.21
RCX3WM30NP	64	5.62	30	2.61	4.1	0.26
RCX3WM36NP	71	5.62	36	2.61	4.9	0.31
RCX3WM42NP	77	5.62	42	2.61	5.7	0.36
RCX3WM48NP	85	5.62	48	2.61	6.6	0.42
RCX3WM54NP	93	5.62	54	2.61	7.4	0.47
RCX3WM60NP	101	5.62	60	2.61	8.3	0.52
RCX3WM66NP	158	5.62	66	2.61	9.1	0.57
RCX3WM72NP	166	5.62	72	2.61	9.8	0.62

**RCX3WMP1CH • Chicago Raceway Punch-Out One Side, None Other Side**

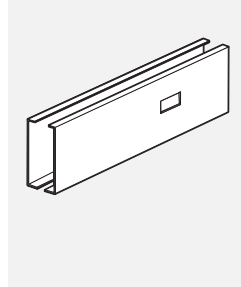

- Metal raceway organizes cables at base.
- To be used with a Chicago Junction Box only
- Snaps directly at the base of the panel.
- When opened, cover's side rests on the floor, providing unobstructed access to data/power installation.

PRODUCT CODE	PRICE	SIZE/ INCHES			WEIGHT VOL	
		H	W	D	LBS	FT <sup>3</sup>
RCX3WM24P1CH	61	5.62	24	2.61	3.3	0.21
RCX3WM30P1CH	70	5.62	30	2.61	4.1	0.26
RCX3WM36P1CH	77	5.62	36	2.61	4.9	0.31
RCX3WM42P1CH	90	5.62	42	2.61	5.7	0.36
RCX3WM48P1CH	97	5.62	48	2.61	6.6	0.42
RCX3WM54P1CH	105	5.62	54	2.61	7.4	0.47
RCX3WM60P1CH	114	5.62	60	2.61	8.3	0.52
RCX3WM66P1CH	120	5.62	66	2.61	9.1	0.57
RCX3WM72P1CH	127	5.62	72	2.61	9.8	0.62

**RCX3WMP2CH • Chicago Raceway Punch-Out Both Side**

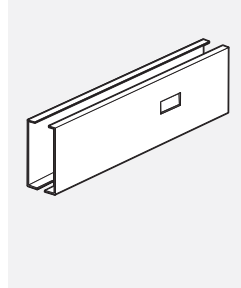

- Metal raceway organizes cables at base.
- To be used with a Chicago Junction Box only
- Snaps directly at the base of the panel.
- When opened, cover's side rests on the floor, providing unobstructed access to data/power installation.

PRODUCT CODE	PRICE	SIZE/ INCHES			WEIGHT VOL	
		H	W	D	LBS	FT <sup>3</sup>
RCX3WM24P2CH	61	5.62	24	2.61	3.3	0.21
RCX3WM30P2CH	70	5.62	30	2.61	4.1	0.26
RCX3WM36P2CH	77	5.62	36	2.61	4.9	0.31
RCX3WM42P2CH	90	5.62	42	2.61	5.7	0.36
RCX3WM48P2CH	97	5.62	48	2.61	6.6	0.42
RCX3WM54P2CH	104	5.62	54	2.61	7.4	0.47
RCX3WM60P2CH	114	5.62	60	2.61	8.3	0.52
RCX3WM66P2CH	120	5.62	66	2.61	9.1	0.57
RCX3WM72P2CH	128	5.62	72	2.61	9.8	0.62

**BG3JB-CH • Chicago Junction Box - Raceway**

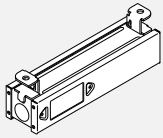

- Provides single power entry from floor raceway.
- Single Ceiling Feed has a 6" whip, liquid tight.
- Raceway connection replaces one Duplex Receptacle Block in a standard kit.

PRODUCT CODE	PRICE	SIZE/INCHES			WEIGHT VOL	
		H	W	D	LBS	FT <sup>3</sup>
BG3JBP1CH	223	2.09	9.78	2.42	1.98	0.03
BG3JBP2CH	230	2.09	9.78	2.42	1.98	0.03

**BH3JB-CH • Chicago Junction Box - Face Mount**

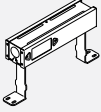

- Provides single power entry from ceiling through a post into raceway.
- Raceway connection replaces one Duplex Receptacle Block in a standard kit.

PRODUCT CODE	PRICE	SIZE/INCHES			WEIGHT VOL	
		H	W	D	LBS	FT <sup>3</sup>
BH3JBP1CH	247	2.09	9.78	2.42	1.98	0.03
BH3JBP2CH	253	2.09	9.78	2.42	1.98	0.03

**B3HWA • Wall Adapter**

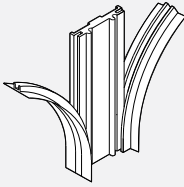

- Starts a run of panels off an existing wall.
- Includes 2 "Capture Strip" panel connectors and 1 pair of raceway end caps.
- Mounting hardware not included.
- Mounting hardware selection should be based on wall or wall stud material.
- Wall Adapter adds 5/16" to a panels run.

PRODUCT CODE	PRICE	SIZE/INCHES			WEIGHT VOL	
		H	W	D	LBS	FT <sup>3</sup>
B3HWA034	48	34	2.61	0.375	2	0.011
B3HWA042	56	42	2.61	0.375	3	0.015
B3HWA050	64	50	2.61	0.375	3	0.018
B3HWA054	72	54	2.61	0.375	3	0.020
B3HWA058	72	58	2.61	0.375	4	0.021
B3HWA066	72	66	2.61	0.375	4	0.021

**BHWASL • Adapter Sleeve**



- Wall Adapter Sleeve is attached to the building to provide flexible support to a panel run.
- As opposed to the BHWA wall adapter, which connects to the panels rigidly to a wall, B1 and B3 Boulevard panels rest inside of the vertical "U" channel, providing up to 3.5" of flexible adjustment.
- For panel runs taller than 66" order two Wall Adapter Sleeves and either have it cut short on the site below ceiling, or cut a rectangular hole in the ceiling tile. Rectangular slots in the Channels correspond to 66", 58", 54", 50" and 42" high B1 and B3 panels.
- Powder coated steel; specify metal finish.
- Note: the Wall Adapter Sleeve provides flexible, non-structural connection, blocks vertical 1" increment clots and cannot, therefore, be used to support overheads and worksurfaces, they must be supported by perpendicular panels, c-legs or gables.
- Note: no fasteners are provided with the Wall Adapter Sleeve. Select the appropriate fasteners according to a structurally sound connection.
- Cannot be used to support a door or panel and cannot be used with laminate, airflow or metal skin panels.

PRODUCT CODE	PRICE	SIZE/INCHES			WEIGHT VOL	
		H	W	D	LBS	FT <sup>3</sup>
BHWASL42	201	34.7	4	2	2.5	0.161
BHWASL50	216	42.7	4	2	3.6	0.148
BHWASL54	223	46.7	4	2	4.2	0.216
BHWASL58	231	52.7	4	2	5.1	0.244
BHWASL66	249	58.7	4	2	6.0	0.272

**BH3CS • Capture Strip Slot Cover**



- An extruded PVC channel to adjoin two panels or a panel to a post. Runs the full length of the panel on both sides providing a positive connection of the "Knuckle-Loc" design.
- Priced per pair.
- Pliable side membranes cover panel slots.
- Included with panel components.
- Only to be ordered separately if required.

PRODUCT CODE	PRICE	SIZE/INCHES			WEIGHT VOL	
		H	W	D	LBS	FT <sup>3</sup>
BH3CS34	15	37			0.24	0.11
BH3CS42	15	42			0.28	0.13
BH3CS50	16	50			0.33	0.15
BH3CS54	16	54			0.31	0.17
BH3CS66	25	66			0.4	0.19

**BH3CE • End Strip Slot Cover**



- End strips with pliable side membrane covers panel slots at end-of-run.
- Priced per pair.
- Included with panel components.
- Only to be ordered separately if required.

PRODUCT CODE	PRICE	SIZE/INCHES			WEIGHT VOL	
		H	W	D	LBS	FT <sup>3</sup>
BH3CE34	12	37			0.12	0.05
BH3CE42	12	42			0.14	0.06
BH3CE50	15	50			0.16	0.07
BH3CE54	15	54			0.31	0.08
BH3CE66	16	66			0.20	0.09

**BA3VTR • Vertical Aluminum End Trim**



- Finishes the vertical edges of panels and posts (90 and 60 degree).
- In the case of the panel, the trim runs from the top of the panel to the bottom of the raceway, enclosing the horizontal channel openings and the raceway opening.
- In the case of the Over Panel, the trim runs from the top of the Over Panel to the bottom of the Over Panel, enclosing the horizontal channel openings.

PRODUCT CODE	PRICE	TYPE	SIZE/INCHES			WEIGHT VOL	
			H	W	D	LBS	FT <sup>3</sup>
BA3VTR34	72	REGULAR PANEL	34	2.61	0.25	1.1	0.03
BA3VTR42	82		42	2.61	0.25	1.4	0.03
BA3VTR50	95		50	2.61	0.25	1.7	0.04
BA3VTR54	112		54	2.61	0.25	1.9	0.04
BA3VTR58	118		58	2.61	0.25	2.1	0.05
BA3VTR66	125		66	2.61	0.25	2.2	0.05
BA3VTE16	38	OVER PANEL	16	2.61	0.25	0.5	0.03
BA3VTE32	72		32	2.61	0.25	1.1	0.06

**BA3VTS • Vertical Aluminum End Trim Standard Step Down**

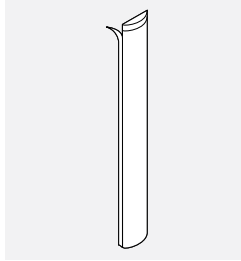

- Finishes the vertical edges of panels and posts (90 and 60 degree).
- Trims run from the top of one panel to the top of lower panel enclosing the horizontal channel opening.

PRODUCT CODE	PRICE	SIZE/INCHES			WEIGHT VOL	
		H	W	D	LBS	FT <sup>3</sup>
BA3VTS04	10	4	2.61	0.25	0.2	0.010
BA3VTS08	26	8	2.61	0.25	0.3	0.015
BA3VTS12	33	12	2.61	0.25	0.4	0.022
BA3VTS16	38	16	2.61	0.25	0.5	0.030
BA3VTS20	45	20	2.61	0.25	0.7	0.039
BA3VTS24	53	24	2.61	0.25	0.9	0.045
BA3VTS32	72	32	2.61	0.25	1.1	0.060

**BV3VTR • Vertical PVC End Trim**

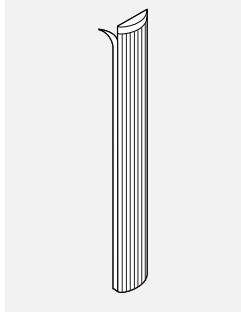

- Finishes the vertical edges of panels and posts (90 and 60 degree).
- In the case of the panel, the trim runs from the top of the panel to the bottom of the raceway, enclosing the horizontal channel openings and the raceway opening.
- In the case of the over panel, the trim runs from the top of the over panel to the bottom of the over panel, enclosing the horizontal channel openings.

PRODUCT CODE	PRICE	TYPE	SIZE/INCHES			WEIGHT VOL	
			H	W	D	LBS	FT <sup>3</sup>
BV3VTR34	48	REGULAR PANEL	34	2.61	0.25	0.6	0.030
BV3VTR42	52		42	2.61	0.25	0.7	0.030
BV3VTR50	64		50	2.61	0.25	0.9	0.040
BV3VTR54	72		54	2.61	0.25	1.0	0.045
BV3VTR58	76		58	2.61	0.25	1.0	0.047
BV3VTR66	81		66	2.61	0.25	1.1	0.050
BV3VTE16	33	OVER PANEL	16	2.61	0.25	0.3	0.030
BV3VTE32	48		32	2.61	0.25	0.6	0.060

**BV3VTS • Vertical PVC End Trim Standard Step Down**

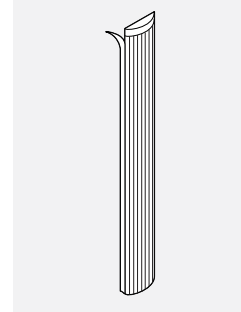

- Finishes the vertical edges of panels and posts (90 and 60 degree).
- Trims run from the top of one panel to the top of lower panel enclosing the horizontal channel opening.

PRODUCT CODE	PRICE	SIZE/INCHES			WEIGHT VOL	
		H	W	D	LBS	FT <sup>3</sup>
BV3VTS04	10	3.75	2.61	0.25	0.1	0.010
BV3VTS08	15	7.75	2.61	0.25	0.1	0.015
BV3VTS12	25	11.75	2.61	0.25	0.2	0.020
BV3VTS16	28	15.75	2.61	0.25	0.3	0.030
BV3VTS20	33	19.75	2.61	0.25	0.3	0.035
BV3VTS24	41	23.75	2.61	0.25	0.4	0.045
BV3VTS32	48	31.75	2.61	0.25	0.6	0.060

**BA3VTRF • Vertical Aluminum Flat End Trim**

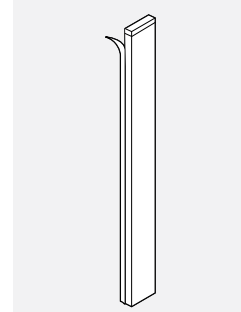

- Finishes the vertical edges of panels and posts (90 and 60 degree).
- In the case of the panel, the trim runs from the top of the panel to the bottom of the raceway, enclosing the horizontal channel openings and the raceway opening.
- In the case of the over panel, the trim runs from the top of the over panel to the bottom of the over panel, enclosing the horizontal channel openings.
- BABVTRF119 cannot ship via courier and must be combined with other product.

PRODUCT CODE	PRICE	TYPE	SIZE/INCHES			WEIGHT VOL	
			H	W	D	LBS	FT <sup>3</sup>
BA3VTRF34	72	REGULAR PANEL	34	2.61	0.125	1.1	0.03
BA3VTRF42	82		42	2.61	0.125	1.4	0.03
BA3VTRF50	95		50	2.61	0.125	1.7	0.04
BA3VTRF54	112		54	2.61	0.125	1.9	0.04
BA3VTRF58	118		58	2.61	0.125	1.9	0.04
BA3VTRF66	125		66	2.61	0.125	2.2	0.05
BA3VTRF119	190		119	2.61	0.125	3.6	0.08
BA3VTEF8	17	OVER PANEL	8	2.61	0.125	0.2	0.01
BA3VTEF16	38		16	2.61	0.125	0.5	0.03
BA3VTEF32	72		32	2.61	0.125	1.1	0.06

**BA3VTSF • Vertical Aluminum Flat End Trim Standard Step Down**

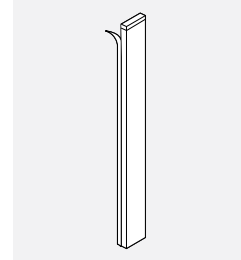

- Finishes the vertical edges of panels and posts (90 and 60 degree).
- Trims run from the top of one panel to the top of lower panel enclosing the horizontal channel opening.

PRODUCT CODE	PRICE	SIZE/INCHES			WEIGHT VOL	
		H	W	D	LBS	FT <sup>3</sup>
BA3VTSF04	13	3.75	2.61	0.125	0.1	0.010
BA3VTSF08	26	7.75	2.61	0.125	0.3	0.015
BA3VTSF12	33	11.75	2.61	0.125	0.4	0.020
BA3VTSF16	38	15.75	2.61	0.125	0.5	0.030
BA3VTSF20	45	19.75	2.61	0.125	0.8	0.035
BA3VTSF24	53	23.75	2.61	0.125	0.9	0.045
BA3VTSF32	72	31.75	2.61	0.125	1.1	0.060

**B3LEP-NC • End-of-Run Gallery Panel in a T configuration, No Connectors for Additional Gallery Panels**

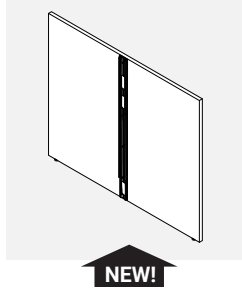

- Provides floor standing support while enclosing the end of a panel run on two sides.
- Attaches to the end of a Boulevard Panel with capture strips to form a T configuration.
- Connection is on the interior face center.
- Includes all attachment hardware and glides.
- Total height is inclusive of panel glides extended to their full height.
- 51" wide gallery panel accommodates two 24" deep surfaces while the 63" wide accommodates two 30" deep surfaces and 75" wide two 36" deep surfaces.
- Please specify LP laminate finish and PVC edge finish.
- If a wood grain laminate is chosen, grain direction run horizontally.
- Edged in PVC on three exposed edges and self edged on bottom.

PRODUCT CODE	PRICE LP	SIZE/INCHES			WEIGHT LBS	VOL FT <sup>3</sup>
		H	W	D		
B3LEP4227NC	606	42	26.5	1	29.49	0.64
B3LEP4251NC	951	42	51	1	55.17	1.24
B3LEP4263NC	1065	42	63	1	68.01	1.53
B3LEP4275NC	1185	42	75	1	80.86	1.82
B3LEP5027NC	707	50	26.5	1	35.25	0.77
B3LEP5051NC	1104	50	51	1	65.92	1.48
B3LEP5063NC	1244	50	63	1	81.27	1.82
B3LEP5075NC	1404	50	75	1	96.62	2.17
B3LEP5427NC	707	54	26.5	1	38.12	0.83
B3LEP5451NC	1137	54	51	1	71.3	1.59
B3LEP5463NC	1281	54	63	1	87.9	1.97
B3LEP5475NC	1448	54	75	1	104.49	2.34

**B3LSEPL-NC • Left End-of-Run Single Gallery Panel in L Configuration, No Connectors for Additional Gallery Panels**

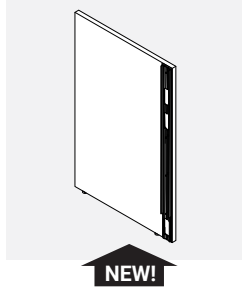

- Provides floor standing support while enclosing the end of a panel run on one side.
- Attaches to the end of a Boulevard Panel with capture strips to form an L configuration.
- Connection is on interior face near it's right end.
- Includes all attachment hardware and glides.
- Total height is inclusive of panel glides extended to their full height.
- 27" wide gallery panel accommodates a 24" deep surface while the 33" wide accommodates a 30" deep surface and 39" wide a 36" deep surface.
- Please specify LP laminate finish and PVC edge finish.
- If a wood grain laminate is chosen, grain direction run horizontally.
- Edged in PVC on three exposed edges and self edged on bottom.

PRODUCT CODE	PRICE LP	SIZE/INCHES			WEIGHT LBS	VOL FT <sup>3</sup>
		H	W	D		
B3LSEPL4215NC	498	42	14.25	1	16.64	0.35
B3LSEPL4227NC	725	42	27	1	29.47	0.66
B3LSEPL4233NC	782	42	33	1	35.89	0.80
B3LSEPL4239NC	822	42	39	1	42.32	0.95
B3LSEPL5015NC	567	50	14.25	1	19.9	0.41
B3LSEPL5027NC	824	50	27	1	35.23	0.78
B3LSEPL5033NC	893	50	33	1	42.9	0.95
B3LSEPL5039NC	956	50	39	1	50.57	1.13
B3LSEPL5415NC	567	54	14.25	1	21.52	0.45
B3LSEPL5427NC	848	54	27	1	38.1	0.84
B3LSEPL5433NC	921	54	33	1	46.4	1.03
B3LSEPL5439NC	986	54	39	1	54.7	1.22

**B3LSEPR-NC • Right End-of-Run Single Gallery Panel in L Configuration, No Connectors for Additional Gallery Panels**

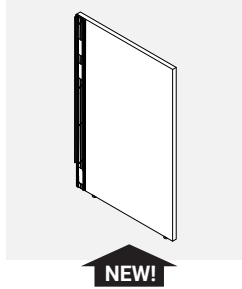

- Provides floor standing support while enclosing the end of a panel run on one side.
- Attaches to the end of a Boulevard Panel with capture strips to form an L configuration.
- Connection is on interior face near it's right end.
- - Includes all attachment hardware and glides.
- Total height is inclusive of panel glides extended to their full height.
- 27" wide gallery panel accommodates a 24" deep surface while the 33" wide accommodates a 30" deep surface and 39" wide a 36" deep surface.
- Please specify LP laminate finish and PVC edge finish.
- If a wood grain laminate is chosen, grain direction run horizontally.
- Edged in PVC on three exposed edges and self edged on bottom.

PRODUCT CODE	PRICE LP	SIZE/INCHES			WEIGHT LBS	VOL FT <sup>3</sup>
		H	W	D		
B3LSEPR4215NC	498	42	14.25	1	16.64	0.35
B3LSEPR4227NC	725	42	27	1	29.47	0.66
B3LSEPR4233NC	782	42	33	1	35.89	0.80
B3LSEPR4239NC	822	42	39	1	42.32	0.95
B3LSEPR5015NC	567	50	14.25	1	19.9	0.41
B3LSEPR5027NC	824	50	27	1	35.23	0.78
B3LSEPR5033NC	893	50	33	1	42.9	0.95
B3LSEPR5039NC	956	50	39	1	50.57	1.13
B3LSEPR5415NC	567	54	14.25	1	21.52	0.45
B3LSEPR5427NC	848	54	27	1	38.1	0.84
B3LSEPR5433NC	921	54	33	1	46.4	1.03
B3LSEPR5439NC	986	54	39	1	54.7	1.22

**B3LMP-NC • Middle-of-Run Single Gallery Panel in X Configuration, No Connectors for Additional Gallery Panels**

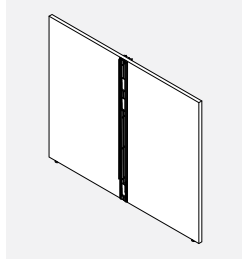

- Provides floor standing support in the middle of a panel run.
- Attaches between panels in a straight Boulevard Panel run with capture strips to form an X configuration.
- Connections are at the center of the interior and exterior faces.
- Includes all attachment hardware and glides.
- Total height is inclusive of panel glides extended to their full height.
- 51" wide gallery panel accommodates two 24" deep surfaces while the 63" wide accommodates two 30" deep surfaces and 75" wide two 36" deep surfaces.
- Please specify LP laminate finish and PVC edge finish.
- If a wood grain laminate is chosen, grain direction run horizontally.
- Edged in PVC on three exposed edges and self edged on bottom.

PRODUCT CODE	PRICE LP	SIZE/INCHES			WEIGHT LBS	VOL FT <sup>3</sup>
		H	W	D		
B3LMP4251NC	1260	42	51	1	55.98	1.24
B3LMP4263NC	1373	42	63	1	68.83	1.53
B3LMP4275NC	1497	42	75	1	81.68	1.85
B3LMP5051NC	1428	50	51	1	66.97	1.48
B3LMP5063NC	1569	50	63	1	82.32	1.82
B3LMP5075NC	1730	50	75	1	97.67	2.17
B3LMP5451NC	1470	54	51	1	72.46	1.59
B3LMP5463NC	1616	54	63	1	89.06	1.97
B3LMP5475NC	1781	54	75	1	105.66	2.34



**B3LSMP-NC • Middle-of-Run Single Gallery Panel in T Configuration, No Connectors for Additional Gallery Panels**

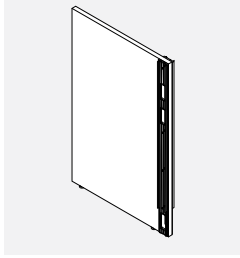

- Provides floor standing support at the middle of a panel run.
- Attaches in the middle of a straight Boulevard Panel run with capture strips to form a T configuration.
- Connections are on the interior and exterior faces of one end.
- Includes all attachment hardware and glides.
- Total height is inclusive of panel glides extended to their full height.
- 27" wide gallery panel accommodates a 24" deep surface while the 33" wide accommodates a 30" deep surface and 39" wide a 36" deep surface.
- Please specify LP laminate finish and PVC edge finish.
- If a wood grain laminate is chosen, grain direction run horizontally.
- Edged in PVC on three exposed edges and self edged on bottom.

PRODUCT CODE	PRICE LP	SIZE /INCHES			WEIGHT LBS	VOL FT <sup>3</sup>
		H	W	D		
B3LSMP4227NC	1037	42	27	1	30.28	0.66
B3LSMP4233NC	1091	42	33	1	36.71	0.80
B3LSMP4239NC	1133	42	39	1	43.13	0.95
B3LSMP5027NC	1148	50	27	1	36.28	0.78
B3LSMP5033NC	1217	50	33	1	43.95	0.95
B3LSMP5039NC	1280	50	39	1	51.63	1.13
B3LSMP5427NC	1182	54	27	1	39.26	0.84
B3LSMP5433NC	1254	54	33	1	47.56	1.03
B3LSMP5439NC	1319	54	39	1	55.86	1.22

**B3LEP • End-of-Run Gallery Panel in a T configuration, With Connectors for Additional Gallery Panels**

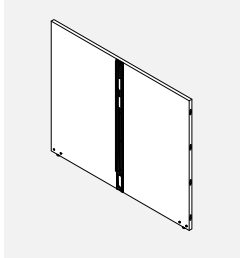

- Provides floor standing support while enclosing the end of a panel run.
- Attaches to the end of a Boulevard panel with capture strips to form a T configuration.
- Connections at both ends as well as on the middle of interior face.
- The end connections are to connect other Gallery Panels.
- The side right is compatible with right hand Gallery Panels (B3LXPRxxxx and B3LXPRxxxxNC, B3L2PRxxxx and B3L3PRxxxx) only.
- The left side is compatible with left hand Gallery Panels (B3LXPLxxxx and B3LXPLxxxxNC, B3L2PLxxxx and B3L3PLxxxx) only.
- The middle interior face connections are for Boulevard panels.
- Includes all attachment hardware and glides.
- Total height is inclusive of panel glides extended to their full height.
- 51" wide gallery panel accommodates two 24" deep surface while the 63" wide accommodates two 30" deep surfaces and 75" wide two 36" deep surfaces.
- Please specify LP laminate finish and PVC edge finish.
- If a wood grain laminate is chosen, grain direction run horizontally.
- Gallery panel is edged in PVC on exposed top edge only and self edged on the three other edges.

PRODUCT CODE	PRICE LP	SIZE /INCHES			WEIGHT LBS	VOL FT <sup>3</sup>
		H	W	D		
B3LEP4251	972	42	51	1	55.25	1.24
B3LEP4263	1085	42	63	1	68.1	1.53
B3LEP4275	1206	42	75	1	80.95	1.82
B3LEP5051	1125	50	51	1	66.01	1.48
B3LEP5063	1265	50	63	1	81.36	1.82
B3LEP5075	1425	50	75	1	96.71	2.17
B3LEP5451	1158	54	51	1	71.38	1.59
B3LEP5463	1302	54	63	1	87.98	1.97
B3LEP5475	1469	54	75	1	104.58	2.34

**B3LSEPL • Left End-of-Run Single Gallery Panel in L Configuration, With Connectors for Additional Gallery Panels**

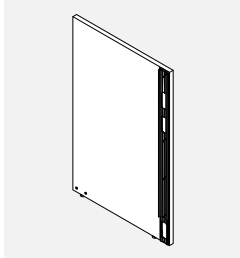

- Provides floor standing support while enclosing the end of a panel run.
- Attaches at the end of a Boulevard panel with capture strips to form an L configuration.
- Connection to the Boulevard panel is on interior face near it's right end.
- Connections for a Gallery Panel are on the left edge.
- Compatible with left hand Gallery Panels (B3LXPLxxxx and B3LXPLxxxxNC, B3L2PLxxxx and B3L3PLxxxx) only.
- Includes all attachment hardware and glides.
- Total height is inclusive of panel glides extended to their full height.
- 27" wide gallery panel accommodates a 24" deep surface while the 33" wide accommodates a 30" deep surface and 39" wide a 36" deep surface.
- Please specify LP laminate finish and PVC edge finish.
- If a wood grain laminate is chosen, grain direction run horizontally.
- Edged in PVC on two exposed edges, self edged on connecting to gallery panel edge and the bottom.

PRODUCT CODE	PRICE LP	SIZE /INCHES			WEIGHT LBS	VOL FT <sup>3</sup>
		H	W	D		
B3LSEPL4227	735	42	27	1	29.51	0.66
B3LSEPL4233	792	42	33	1	35.94	0.80
B3LSEPL4239	831	42	39	1	42.36	0.95
B3LSEPL5027	834	50	27	1	35.27	0.78
B3LSEPL5033	905	50	33	1	42.94	0.95
B3LSEPL5039	968	50	39	1	50.62	1.13
B3LSEPL5427	858	54	27	1	38.14	0.84
B3LSEPL5433	930	54	33	1	46.44	1.03
B3LSEPL5439	995	54	39	1	54.74	1.22

**B3LSEPR • Right End-of-Run Single Gallery Panel in L Configuration, With Connectors for Additional Gallery Panels**

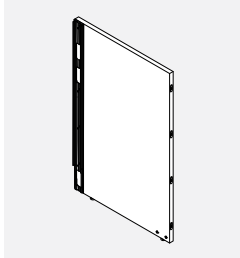

- Provides floor standing support while enclosing the end of a panel run.
- Attaches at the end of a Boulevard panel with capture strips to form an L configuration.
- Connection to the Boulevard panel is on interior face near it's left end.
- Connections for a Gallery Panel are on the right edge.
- Compatible with right hand Gallery Panels (B3LXPRxxxx and B3LXPRxxxxNC, B3L2PRxxxx and B3L3PRxxxx) only.
- Includes all attachment hardware and glides.
- Total height is inclusive of panel glides extended to their full height.
- 27" wide gallery panel accommodates a 24" deep surface while the 33" wide accommodates a 30" deep surface and 39" wide a 36" deep surface.
- Please specify LP laminate finish and PVC edge finish.
- If a wood grain laminate is chosen, grain direction run horizontally.
- Edged in PVC on two exposed edges, self edged on connecting to gallery panel edge and the bottom.

PRODUCT CODE	PRICE LP	SIZE /INCHES			WEIGHT LBS	VOL FT <sup>3</sup>
		H	W	D		
B3LSEPR4227	735	42	27	1	29.51	0.66
B3LSEPR4233	792	42	33	1	35.94	0.80
B3LSEPR4239	831	42	39	1	42.36	0.95
B3LSEPR5027	834	50	27	1	35.27	0.78
B3LSEPR5033	905	50	33	1	42.94	0.95
B3LSEPR5039	968	50	39	1	50.62	1.13
B3LSEPR5427	858	54	27	1	38.14	0.84
B3LSEPR5433	930	54	33	1	46.44	1.03
B3LSEPR5439	995	54	39	1	54.74	1.22

**B3LMP • Middle-of-Run Single Gallery Panel in X Configuration, With Connectors for Additional Gallery Panels**

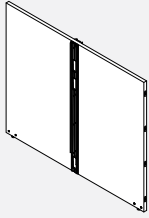

- Provides floor standing support in the middle of a panel run.
- Attached in the middle of a straight Boulevard Panel run with capture strips to form an X configuration.
- Connections at both ends (for Gallery Panels) as well as on the middle of the interior and exterior faces (for Boulevard Panels).
- The right side is compatible with right hand Gallery Panels (B3LXPRxxxx and B3LXPRxxxxNC, B3L2PRxxxx and B3L3PRxxxx) only.
- The left side is compatible with left hand Gallery Panels (B3LXPLxxxx and B3LXPLxxxxNC, B3L2PLxxxx and B3L3PLxxxx) only.
- Includes all attachment hardware and glides.
- Total height is inclusive of panel glides extended to their full height.
- 51" wide gallery panel accommodates two 24" deep surface while the 63" wide accommodates two 30" deep surfaces and 75" wide two 36" deep surfaces.
- Please specify LP laminate finish and PVC edge finish.
- If a wood grain laminate is chosen, grain direction run horizontally.
- Edged in PVC on exposed top edge only and self edged on the three other.

PRODUCT CODE	PRICE	SIZE/INCHES			WEIGHT	VOL
	LP	H	W	D	LBS	FT <sup>3</sup>
B3LMP4251	1281	42	51	1	56.07	1.24
B3LMP4263	1395	42	63	1	68.91	1.53
B3LMP4275	1517	42	75	1	81.76	1.82
B3LMP5051	1449	50	51	1	67.06	1.48
B3LMP5063	1587	50	63	1	82.41	1.82
B3LMP5075	1749	50	75	1	97.76	2.17
B3LMP5451	1491	54	51	1	72.55	1.59
B3LMP5463	1635	54	63	1	89.15	1.97
B3LMP5475	1802	54	75	1	105.74	2.34

**B3LSMP • Middle-of-Run Single Gallery Panel in T Configuration, With Connectors for Additional Gallery Panels**



- Provides floor standing support at the middle of a panel run.
- Attached in the middle of a straight Boulevard Panel run with capture strips to form a T configuration.
- Connections are on the exposed edge (for Gallery Panel) and near the opposite end on both interior and exterior faces (for Boulevard Panels).
- Compatible with left hand gallery panels (B3LXPLxxxx and B3LXPLxxxxNC, B3L2PLxxxx and B3L3PLxxxx) only.
- Includes all attachment hardware and glides.
- Total height is inclusive of panel glides extended to their full height.
- 27" wide gallery panel accommodates a 24" deep surface while the 33" wide accommodates a 30" deep surface and 39" wide a 36" deep surface.
- Please specify LP laminate finish and PVC edge finish.
- If a wood grain laminate is chosen, grain direction run horizontally.
- Edged in PVC on two exposed edges, self edged on connecting to gallery panel edge and the bottom.

PRODUCT CODE	PRICE	SIZE/INCHES			WEIGHT	VOL
	LP	H	W	D	LBS	FT <sup>3</sup>
B3LSMP4227	1044	42	27	1	30.33	0.66
B3LSMP4233	1103	42	33	1	36.75	0.80
B3LSMP4239	1142	42	39	1	43.17	0.95
B3LSMP5027	1158	50	27	1	36.32	0.78
B3LSMP5033	1227	50	33	1	43.99	0.95
B3LSMP5039	1290	50	39	1	51.67	1.13
B3LSMP5427	1193	54	27	1	39.31	0.84
B3LSMP5433	1265	54	33	1	47.61	1.03
B3LSMP5439	1329	54	39	1	55.91	1.22

**B3LXPL • Left Gallery Panel Extension, With Connectors for Additional Gallery Panels**

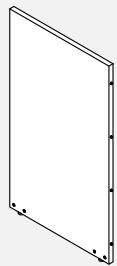

**NEW!**

- Provides floor standing support while extending the Gallery Panels run.
- Attaches to the left edge of a Gallery Panel by the pin connectors to allow for additional Gallery Panels to be added on the left side.
- Pin connectors on the right edge and modular connectors on the left edge of the interior face.
- The right side is compatible with Gallery Panels (B3LEPxxx, B3LSEPL, B3LMPxxx, B3LSMP and B3LXPLxxx) only.
- The left side is compatible with left hand Gallery Panels (B3LXPLxxxx and B3LXPLxxxxNC, B3L2PLxxxx and B3L3PLxxxx) only.
- Includes all attachment hardware and glides.
- Total height is inclusive of panel glides extended to their full height.
- Please specify LP laminate finish and PVC edge finish.
- If a wood grain laminate is chosen, grain direction run horizontally.
- Edged in PVC on exposed top edge only and self edges on the three other.
- Edged in PVC on two exposed edges, self edged on connecting to gallery panel edge and the bottom.

PRODUCT CODE	PRICE	SIZE/INCHES			WEIGHT	VOL
	LP	H	W	D	LBS	FT <sup>3</sup>
B3LXPL4224	378	42	24	1	25.83	0.58
B3LXPL4230	435	42	30	1	32.26	0.73
B3LXPL4236	492	42	36	1	38.68	0.88
B3LXPL4242	548	42	42	1	45.11	1.02
B3LXPL4248	605	42	48	1	51.53	1.17
B3LXPL5024	450	50	24	1	30.83	0.69
B3LXPL5030	521	50	30	1	38.51	0.87
B3LXPL5036	591	50	36	1	46.18	1.04
B3LXPL5042	660	50	42	1	53.86	1.22
B3LXPL5048	731	50	48	1	61.53	1.39
B3LXPL5424	465	54	24	1	33.34	0.75
B3LXPL5430	537	54	30	1	41.64	0.94
B3LXPL5436	608	54	36	1	49.94	1.13
B3LXPL5442	678	54	42	1	58.24	1.31
B3LXPL5448	755	54	48	1	66.54	1.50

**B3LXPR • Right Gallery Panel Extension, With Connectors for Additional Gallery Panels**

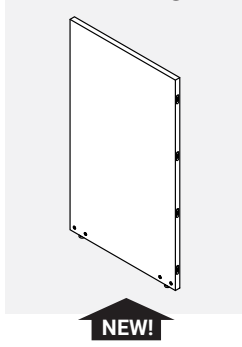

- Provides floor standing support while extending the Gallery Panels run.
- Attaches to the right edge of a Gallery Panel by the pin connectors to allow for additional Gallery Panels to be added on the right side.
- Pin connectors on the right edge and modular connectors on the left edge of the interior face.
- The right side is compatible with right hand Gallery Panels (B3LXPRxxxx and B3LXPRxxxxNC, B3L2PRxxxx and B3L3PRxxxx) only.
- The left side is compatible with Gallery Panels (B3LEPxxx, B3LSEPRxxx, B3LMPxxx and B3LXPRxxx ) only.
- Includes all attachment hardware and glides.
- Total height is inclusive of panel glides extended to their full height.
- Please specify LP laminate finish and PVC edge finish.
- If a wood grain laminate is chosen, grain direction run horizontally.
- Edged in PVC on exposed top edge only and self edges on the three other.

PRODUCT CODE	PRICE LP	SIZE /INCHES			WEIGHT LBS	VOL FT <sup>3</sup>
		H	W	D		
B3LXPR4224	378	42	24	1	25.83	0.58
B3LXPR4230	435	42	30	1	32.26	0.73
B3LXPR4236	492	42	36	1	38.68	0.88
B3LXPR4242	548	42	42	1	45.11	1.02
B3LXPR4248	605	42	48	1	51.53	1.17
B3LXPR5024	450	50	24	1	30.83	0.69
B3LXPR5030	521	50	30	1	38.51	0.87
B3LXPR5036	591	50	36	1	46.18	1.04
B3LXPR5042	660	50	42	1	53.86	1.22
B3LXPR5048	731	50	48	1	61.53	1.39
B3LXPR5424	465	54	24	1	33.34	0.75
B3LXPR5430	537	54	30	1	41.64	0.94
B3LXPR5436	608	54	36	1	49.94	1.13
B3LXPR5442	678	54	42	1	58.24	1.31
B3LXPR5448	755	54	48	1	66.54	1.50

**B3LXPL-NC • Left Gallery Panel Extension, No Connectors for Additional Gallery Panels**

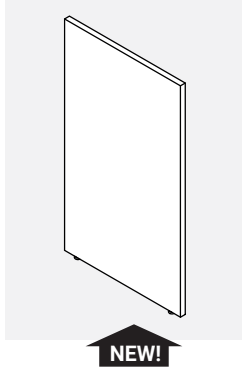

- Provides floor standing support while enclosing the end of a Gallery Panel left run.
- Attached to the left edge of a Gallery Panel by the pin connectors to finish the run.
- Pin connectors are on the right edge of the interior face.
- Compatible with gallery panels (B3LEPxxxx, B3LSEPLxxxx, B3LMPxxxx, B3LSMPxxxx and B3LXPLxxxx) only.
- Includes all attachment hardware and glides.
- Total height is inclusive of panel glides extended to their full height.
- Please specify LP laminate finish and PVC edge finish.
- If a wood grain laminate is chosen, grain direction run horizontally.
- Edged in PVC on two exposed edges, self edged on connecting to gallery panel edge and the bottom.

PRODUCT CODE	PRICE LP	SIZE /INCHES			WEIGHT LBS	VOL FT <sup>3</sup>
		H	W	D		
B3LXPL4212NC	207	42	12	1	12.95	0.29
B3LXPL4224NC	368	42	24	1	25.8	0.58
B3LXPL4230NC	425	42	30	1	32.22	0.73
B3LXPL4236NC	480	42	36	1	38.65	0.88
B3LXPL4242NC	539	42	42	1	45.07	1.02
B3LXPL4248NC	594	42	48	1	51.5	1.17
B3LXPL5012NC	258	50	12	1	15.45	0.35
B3LXPL5024NC	441	50	24	1	30.8	0.69
B3LXPL5030NC	510	50	30	1	38.47	0.87
B3LXPL5036NC	579	50	36	1	46.15	1.04
B3LXPL5042NC	653	50	42	1	53.82	1.22
B3LXPL5048NC	722	50	48	1	61.5	1.39
B3LXPL5412NC	258	54	12	1	16.7	0.38
B3LXPL5424NC	455	54	24	1	33.3	0.75
B3LXPL5430NC	527	54	30	1	41.6	0.94
B3LXPL5436NC	597	54	36	1	49.9	1.13
B3LXPL5442NC	671	54	42	1	58.2	1.31
B3LXPL5448NC	741	54	48	1	66.5	1.50

**B3LXPR-NC • Right Gallery Panel Extension, No Connectors for Additional Gallery Panels**

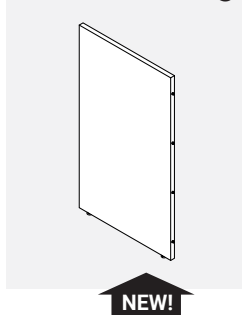

- Provides floor standing support while enclosing the end of a Gallery Panel right run.
- Attached to the right edge of a Gallery Panel by the pin connectors to finish the run.
- Pin connectors are on the left edge of the interior face.
- Compatible with gallery panels (B3LEPxxxx, B3LSEPRxxxx, B3LMPxxxx and B3LXPRxxxx) only.
- Includes all attachment hardware and glides.
- Total height is inclusive of panel glides extended to their full height.
- Please specify LP laminate finish and PVC edge finish.
- If a wood grain laminate is chosen, grain direction run horizontally.
- Edged in PVC on two exposed edges, self edged on connecting to gallery panel edge and the bottom.

PRODUCT CODE	PRICE LP	SIZE /INCHES			WEIGHT LBS	VOL FT <sup>3</sup>
		H	W	D		
B3LXPR4212NC	207	42	12	1	12.95	0.29
B3LXPR4224NC	368	42	24	1	25.8	0.58
B3LXPR4230NC	425	42	30	1	32.22	0.73
B3LXPR4236NC	480	42	36	1	38.65	0.88
B3LXPR4242NC	539	42	42	1	45.07	1.02
B3LXPR4248NC	594	42	48	1	51.5	1.17
B3LXPR5012NC	258	50	12	1	15.45	0.35
B3LXPR5024NC	441	50	24	1	30.8	0.69
B3LXPR5030NC	510	50	30	1	38.47	0.87
B3LXPR5036NC	579	50	36	1	46.15	1.04
B3LXPR5042NC	653	50	42	1	53.82	1.22
B3LXPR5048NC	722	50	48	1	61.5	1.39
B3LXPR5412NC	258	54	12	1	16.7	0.38
B3LXPR5424NC	455	54	24	1	33.3	0.75
B3LXPR5430NC	527	54	30	1	41.6	0.94
B3LXPR5436NC	597	54	36	1	49.9	1.13
B3LXPR5442NC	671	54	42	1	58.2	1.31
B3LXPR5448NC	741	54	48	1	66.5	1.50

**B3L2PR • Right Gallery Panel End-of-Run Return**

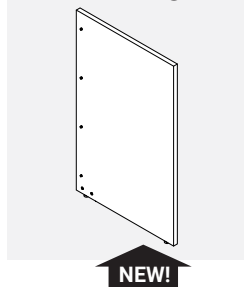

- Provides floor standing support while enclosing the end of a gallery panel run.
- Attaches at the Gallery Panel right edge with connectors to form an L configuration.
- Connections to Gallery Panel are on the interior face near it's left end.
- Compatible with Gallery Panels (B3LEPxxxx, B3LSEPRxxxx, B3LMPxxxx and B3LXPRxxxx) only.
- Includes all attachment hardware and glides.
- Total height is inclusive of panel glides extended to their full height.
- 25" wide gallery panel accommodates a 24" deep surface while the 31" wide accommodates a 30" deep surface and 37" wide a 36" deep surface.
- Please specify LP laminate finish and PVC edge finish.
- If a wood grain laminate is chosen, grain direction run horizontally.
- Edged in PVC on three exposed edges and self edged on the bottom edge.

PRODUCT CODE	PRICE LP	SIZE /INCHES			WEIGHT LBS	VOL FT <sup>3</sup>
		H	W	D		
B3L2PR4213	224	42	13	1	14.02	0.32
B3L2PR4225	425	42	25	1	26.87	0.61
B3L2PR4231	480	42	31	1	33.29	0.75
B3L2PR4237	521	42	37	1	39.72	0.90
B3L2PR5013	279	50	13	1	16.73	0.38
B3L2PR5025	510	50	25	1	32.08	0.72
B3L2PR5031	579	50	31	1	39.75	0.90
B3L2PR5037	642	50	37	1	47.43	1.07
B3L2PR5413	279	54	13	1	18.08	0.41
B3L2PR5425	527	54	25	1	34.68	0.78
B3L2PR5431	597	54	31	1	42.98	0.97
B3L2PR5437	662	54	37	1	51.28	1.16

**B3L2PL • Left Gallery Panel End-of-Run Return**

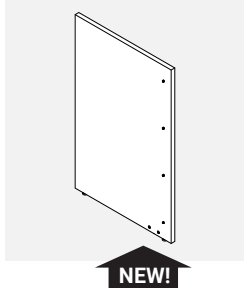

- Provides floor standing support while enclosing the end of a gallery panel run.
- Attaches at the Gallery Panel left edge with connectors to form an L configuration.
- Connections to Gallery Panel are on the interior face near it's right end.
- Compatible with Gallery Panels (B3LEPxxxx, B3LSEPLxxxx, B3LMPxxxx, B3LSMPxxxx and B3LXPLxxxx) only.
- Includes all attachment hardware and glides.
- Total height is inclusive of panel glides extended to their full height.
- 25" wide gallery panel accommodates a 24" deep surface while the 31" wide accommodates a 30" deep surface and 37" wide a 36" deep surface.
- Please specify LP laminate finish and PVC edge finish.
- If a wood grain laminate is chosen, grain direction run horizontally.
- Edged in PVC on three exposed edges and self edged on the bottom edge.

PRODUCT CODE	PRICE LP	SIZE /INCHES			WEIGHT LBS	VOL FT <sup>3</sup>
		H	W	D		
B3L2PL4213	224	42	13	1	14.02	0.32
B3L2PL4225	425	42	25	1	26.87	0.61
B3L2PL4231	480	42	31	1	33.29	0.75
B3L2PL4237	521	42	37	1	39.72	0.90
B3L2PL5013	279	50	13	1	16.73	0.38
B3L2PL5025	510	50	25	1	32.08	0.72
B3L2PL5031	579	50	31	1	39.75	0.90
B3L2PL5037	642	50	37	1	47.43	1.07
B3L2PL5413	279	54	13	1	18.08	0.41
B3L2PL5425	527	54	25	1	34.68	0.78
B3L2PL5431	597	54	31	1	42.98	0.97
B3L2PL5437	662	54	37	1	51.28	1.16

**B3L3PL • Left Gallery Panel End-of-Run 3-Way Return**

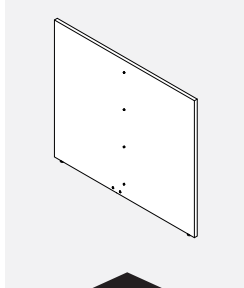

- Provides floor standing support while enclosing the end of a gallery panel run.
- Attaches to the Gallery Panel left edge with connectors to form an T configuration.
- Connections to Gallery Panel are on the interior face in the middle.
- Compatible with Gallery Panels (B3LEPxxxx, B3LSEPLxxxx, B3LMPxxxx, B3LSMPxxxx and B3LXPLxxxx) only.
- Includes all attachment hardware and glides.
- Total height is inclusive of panel glides extended to their full height.
- 49" wide gallery panel accommodates two 24" deep surfaces while the 61" wide accommodates two 30" deep surface and 73" wide two 36" deep surface.
- Please specify LP laminate finish and PVC edge finish.
- If a wood grain laminate is chosen, grain direction run horizontally.
- Edged in PVC on three exposed edges and self edged on the bottom edge.

PRODUCT CODE	PRICE LP	SIZE /INCHES			WEIGHT LBS	VOL FT <sup>3</sup>
		H	W	D		
B3L3PL4225	333	42	25	1	26.87	0.61
B3L3PL4249	576	42	49	1	52.57	1.19
B3L3PL4261	764	42	61	1	65.41	1.48
B3L3PL4273	887	42	73	1	78.26	1.77
B3L3PL5025	417	50	25	1	32.08	0.72
B3L3PL5049	791	50	49	1	62.77	1.42
B3L3PL5061	930	50	61	1	78.12	1.77
B3L3PL5073	1091	50	73	1	93.47	2.11
B3L3PL5425	417	54	25	1	34.68	0.78
B3L3PL5449	815	54	49	1	67.88	1.53
B3L3PL5461	959	54	61	1	84.48	1.91
B3L3PL5473	1125	54	73	1	101.08	2.28

**B3L3PR • Right Gallery Panel End-of-Run 3-Way Return**

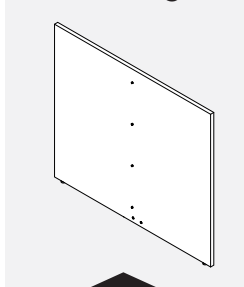

- Provides floor standing support while enclosing the end of a gallery panel run.
- Attaches to the Gallery Panel right edge with connectors to form an T configuration.
- Connections to Gallery Panel are on the interior face in the middle.
- Compatible with gallery panels (B3LEPxxxx, B3LSEPRxxxx, B3LMPxxxx and B3LXPRxxxx) only.
- Includes all attachment hardware and glides.
- Total height is inclusive of panel glides extended to their full height.
- 49" wide gallery panel accommodates two 24" deep surfaces while the 61" wide accommodates two 30" deep surface and 73" wide two 36" deep surface.
- Please specify LP laminate finish and PVC edge finish.
- If a wood grain laminate is chosen, grain direction run horizontally.
- Edged in PVC on three exposed edges and self edged on the bottom edge.

PRODUCT CODE	PRICE LP	SIZE /INCHES			WEIGHT LBS	VOL FT <sup>3</sup>
		H	W	D		
B3L3PR4225	333	42	25	1	26.87	0.61
B3L3PR4249	576	42	49	1	52.57	1.19
B3L3PR4261	764	42	61	1	65.41	1.48
B3L3PR4273	887	42	73	1	78.26	1.77
B3L3PR5025	417	50	25	1	32.08	0.72
B3L3PR5049	791	50	49	1	62.77	1.42
B3L3PR5061	930	50	61	1	78.12	1.77
B3L3PR5073	1091	50	73	1	93.47	2.11
B3L3PR5425	417	54	25	1	34.68	0.78
B3L3PR5449	815	54	49	1	67.88	1.53
B3L3PR5461	959	54	61	1	84.48	1.91
B3L3PR5473	1125	54	73	1	101.08	2.28

**B3HLPBB01 • Gallery Panel Bottom Inline Bracket**

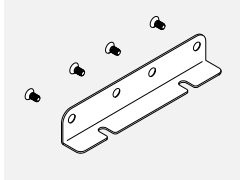

- Gallery Panel Bottom Inline Bracket connects two Gallery Panels at the bottom with screws.
- Available in standard paint colors.

PRODUCT CODE	PRICE	SIZE /INCHES			WEIGHT LBS	VOL FT <sup>3</sup>
		H	W	D		
B3HLPBB01	51	7	1.5	8	1	0.5

**B3HLPCB01 • Gallery Panel Corner Bracket**

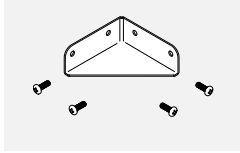

- Gallery Panel Corner Bottom bracket connects two Gallery Panels at 90 degrees.
- Available in standard paint colors.

PRODUCT CODE	PRICE	SIZE /INCHES			WEIGHT LBS	VOL FT <sup>3</sup>
		H	W	D		
B3HLPCB01	50	7	1.5	4	4	0.5

**B3PMP-GI-W • Privacy Glass for 1" Laminate Panels**

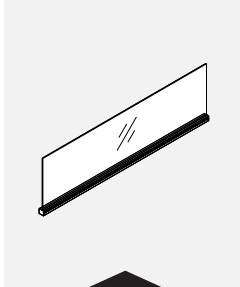

**NEW!**

- Privacy glass integrated with aluminum top trim.
- Attaches on top of gallery panels to add privacy or divide space.
- Includes aluminum trim with channel, end caps and glass tile.
- Top rail may also be used to hang accessories.
- Glass and attachment hardware ship separately.
- Please specify standard paint finish for the channel.
- Standard in clear (CLR) or frosted (FRST).

PRODUCT CODE	PRICE		SIZE /INCHES			WEIGHT LBS	VOL FT <sup>3</sup>
	CLR	FRST	H	W	D		
B3PMP24GI8W	290	356	8	24	1	4.84	0.11
B3PMP30GI8W	315	361	8	30	1	6.06	0.14
B3PMP36GI8W	335	368	8	36	1	7.28	0.17
B3PMP42GI8W	350	405	8	42	1	8.5	0.19
B3PMP48GI8W	369	440	8	48	1	9.72	0.22
B3PMP24GI16W	290	356	16	24	1	8.92	0.22
B3PMP30GI16W	315	361	16	30	1	11.17	0.28
B3PMP36GI16W	335	368	16	36	1	13.43	0.33
B3PMP42GI16W	350	405	16	42	1	15.68	0.39
B3PMP48GI16W	369	440	16	48	1	17.92	0.44

**B3PFD-W • Felt Divider for 1" Laminate Panels**

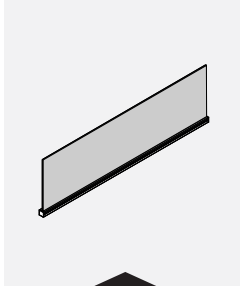

**NEW!**

- Privacy felt integrated with aluminum top trim.
- Attaches on top of gallery panels to add privacy or divide space.
- Includes aluminum trim with channel, end caps and felt tile.
- Top rail may also be used to hang accessories.
- Felt and attachment hardware ship separately.
- Please specify standard paint finish for the channel.
- Please specify standard felt finish.

PRODUCT CODE	PRICE	SIZE /INCHES			WEIGHT LBS	VOL FT <sup>3</sup>
		H	W	D		
B3PFD0824W	116	8	24	1	1.32	0.11
B3PFD0830W	135	8	30	1	1.65	0.14
B3PFD0836W	160	8	36	1	1.99	0.17
B3PFD0842W	180	8	42	1	2.32	0.19
B3PFD0848W	264	8	48	1	2.65	0.22
B3PFD0854W	289	8	54	1	2.98	0.25
B3PFD0860W	310	8	60	1	3.32	0.28
B3PFD0866W	327	8	66	1	3.65	0.31
B3PFD0872W	369	8	72	1	3.98	0.33
B3PFD1624W	132	16	24	1	1.83	0.22
B3PFD1630W	152	16	30	1	2.3	0.28
B3PFD1636W	170	16	36	1	2.76	0.33
B3PFD1642W	195	16	42	1	3.22	0.39
B3PFD1648W	290	16	48	1	3.68	0.44
B3PFD1654W	316	16	54	1	4.14	0.50
B3PFD1660W	338	16	60	1	4.61	0.56
B3PFD1666W	356	16	66	1	5.07	0.61
B3PFD1672W	405	16	72	1	5.53	0.67

**ELECTRICAL**

Affordability and widespread availability of wireless networking is gradually diminishing the need for extensive cable capacity housing. However, as our desk top equipment still requires electricity, providing access to power from within a work station is an integral part of any work place design.

The Teknion family of power components has been assembled to address a variety of common requirements as well as to satisfy specific customer needs and budgets.

Teknion can now offer the option of 3 duplex per panel, please contact your Customer Service Representative.

**Direct Access**

When office equipment plugs directly into a wall or raised floor power source, cable troughs, as well as the Boulevard panel internal cavity serve the purpose of organizing cables.

**Extensions**

Keeping minimal installation costs in mind, the next natural step is the employment of fused and surge protected power bars, worksurface-clamped receptacles or floor standing power towers.

**Four circuit power systems**

In the absence of a raised floor, or when office equipment is to be installed further away from wall outlets, the Boulevard panel the building power supply - office equipment gap by distributing power at either floor or desk height level, or both.

While Boulevard panels are capable of surrounding a given work station with power and data outlets at multiple levels, it is important to remember that the most economical way of providing four-circuit power distribution is if the harness, junction box and receptacle system remained within the central spine structure. The cost savings here come from a number and lengths of individual connecting power harnesses.

Should there be a need to branch power from Boulevard or central spine onto adjacent, perpendicular work surfaces, the employment of fused and surge protected power bars will assist in keeping the cost under control.

However, the very same, 4-circuit system is capable of delivering a considerable amount of power as there can be up to six, 8 wire-4 circuit systems accommodated within System 3 pass-thru panel. For instance: three systems at the floor level and two systems at the desk height.

Various ceiling or floor level power entry feeds are available. See the following pages for individual component description and technical specifications.

**TECHNICAL INFORMATION**

**Wire Schematic**

4-2-2 Wiring Schematic

8-Wire Shared Neutral

"3+1" -3 Utility circuits, 1 dedicated circuit.

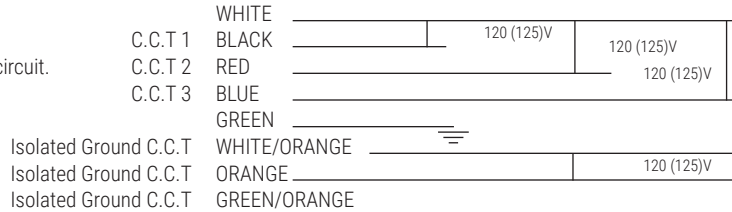

**8 Wires**

- 4 Lines (12 ga.)
- 2 Neutrals (10 ga.)
- 2 Grounds (12 ga.)

**4 Circuits**

- 3 Utility Circuits
- 1 Dedicated Circuits

**Receptacles**

Duplex – Up to 6 duplex receptacles per circuit (Up to 48 infeed)

**Specifications**

System rated for connection to a grounded 120/240 V, single phase\*, 20A, 60Hz or 120/208 V, 3 phase, 20A, 60Hz branch circuit for U.S. and 15A if product is marked with a C-UL Mark. Outlets rated 15A max.

\* When connected to Single Phase. Only Circuit 1,3 & A are available.

**UL Recognized CSA Certified**

**Warning:** It is recommended that installation of the electrical harness be made under the supervision of a licensed electrician in accordance with applicable codes and regulations.

**Special Note:** Always determine that harness is electrically connected to only one power supply.

**STEP-BY-STEP SPECIFICATION - 8 WIRE ELECTRICAL FOR BOULEVARD 1 AND RACEWAY PANELS**

**STEP 1:** Determine the location of the source power entry entering the panel through a post.

- a) From the floor:
  - i) Choose from a selection of single or double Base Feeds (BE81BF721, BE81BF722, BE81BF1441, BE81BF1442) to bring the power from the floor to the raceway channel.
  - ii) Select a post adjacent to the panel (or panels if using a Double Base Feed) to which the end of the Base Feed will be attached. This panel requires a Power Distribution Housing and must be located next to the post through which the Base Feed is entering.

**Note: If it is not practical to have a Power Distribution Housing in a panel adjacent to the selected Base Feed Post, use a BE8CPxxHJ Housing-to-Jumper Pass-Thru Cable to transition through the adjacent non-powered panel(s) that are between the Base Feed Post and the first powered panel. The length of the cable will equal the combined width of the non-powered panel(s).**

- b) From the Ceiling:
  - i) Choose from a selection of single or double Ceiling Feeds (BE81CF1201, BE81CF12a0-2, BE81CF1441, BE81CF1442) to bring the power from the ceiling to the raceway.
  - ii) Select a post adjacent to the panel (or panels if using a Double Ceiling Feed) to which the Ceiling Feed will be attached. This panel requires a Power Distribution Housing and must be located next to the post through which the Ceiling Feed is entering.

**STEP 2:** Determine which panels are to be powered.

- a) Use a BE81D Concealed Desk Height Power Distribution Housing or a BE8U2D Face-Mount Desk Height Power Distribution Housing that corresponds with the width of each panel selected to be powered.

**Note: Specify Face-Mount Raceway Covers for panels that contain BE8U2D Face-Mount Desk Height Power Distribution Housings.**

**STEP 3:** Connect power to the panels.

- a) Use a BE8JC16 Jumper between two adjacent powered panels.
- b) Use a BE8JC20 Jumper between two powered panels separated by a post.
- c) **Use a BE8JM19 Shielded Mesh Jumper between two powered panels separated by a post.**
- d) Use a BE8CPxxHJ Housing-to-Jumper Pass-Thru Cable to electrically connect a BE8JM19 Shielded Mesh Jumper and a powered panel when the two are separated by one or more non-powered panels in a straight line application only.
  - i) The length of the BE8CPxxHJ Housing-to-Jumper Pass-Thru Cable will equal the combined width of the non-powered panel(s).
- e) Use a BE8CPxxHH Housing-to-Housing Pass-Thru Cable to electrically connect two powered panel separated by one or more non-powered panels in a straight line application only.
  - i) The length of the Pass-Thru Cable corresponds with the width(s) of the non-powered panels that separate two powered panels plus 16" (the termination blocks of the Power Distribution Housing are 8" in from the edge of the powered panel), plus 4" for each post.
- f) Connect two jumpers or cables together by using the I-Connector BE8C11. This functions as a female-female adapter and it allows the male ends of jumpers and pass-thru cables to connect together.

**STEP 4:** Designate which circuit each duplex is to tap into.

- a) Each powered panel has four (4) potential locations for duplex receptacles - 2 per side. (Exception: 24" wide panel has only two (2) potential locations - 1 per side, 18" wide panel has no locations for receptacles).
- b) At each location there is a choice of four (4) circuit options. Select the circuit option for each location.

**Circuit Selections : Circuits 1, 2, and 3 are utility circuits, all sharing a ground and a neutral. Circuit A is a dedicated circuit with its own ground and neutral.**

**SPECIFICATION APPLICATIONS**

**Boulevard 1 Jumper Applications**

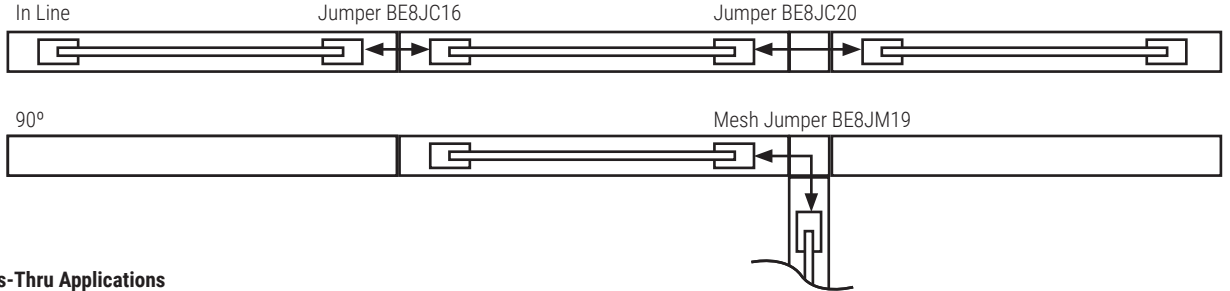

**Boulevard 1 Pass-Thru Applications**

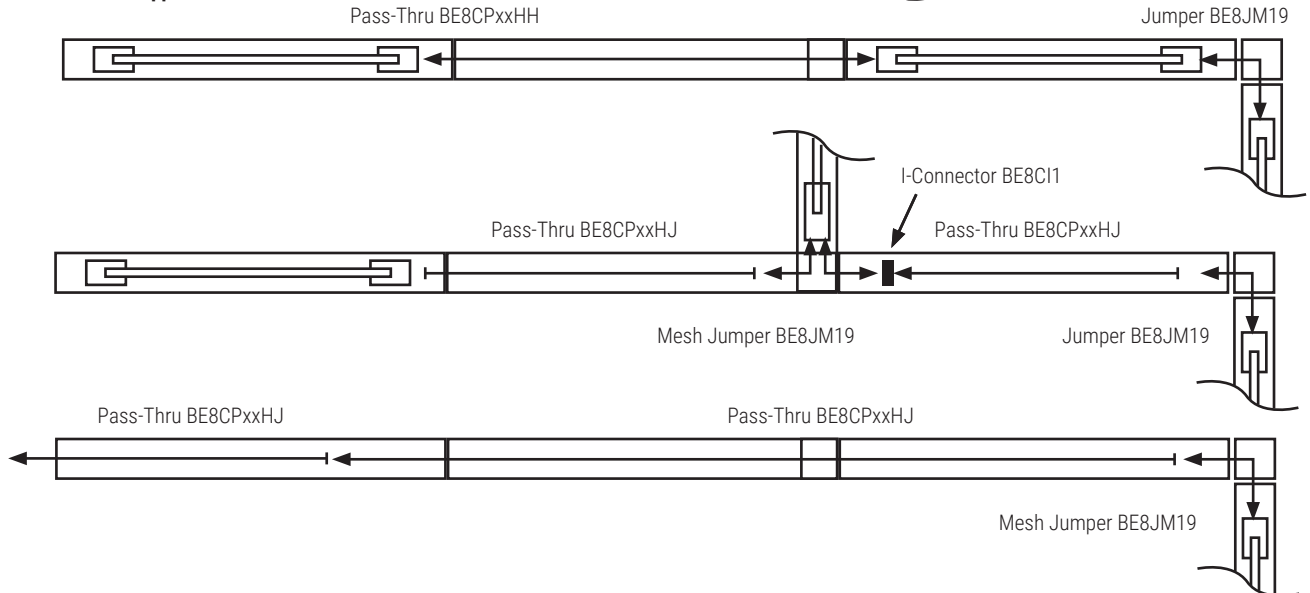

**STEP-BY-STEP SPECIFICATION - 8 WIRE ELECTRICAL FOR BOULEVARD SYSTEM 3 BASE RACEWAY**

**STEP 1:** Determine the location of the source power entry entering the panel.

- a. At the base of a panel:
  - i. Use a BE8BFxx Base Feed.
  - ii. Select the panel to which the Base Feed will be attached. This panel requires a BE83D Power Distribution Housing.
  - iii. Select the side of the panel and the receptacle outlet to which the Base Feed is to be attached.
- b. From the ceiling:
  - i. Use a BE8CFxx-1 or -2 (single or double).
  - ii. Select the post through which to feed the Ceiling Feed.
  - iii. One panel adjacent to the selected post requires a BE83D Power Distribution Housing. Attach the Ceiling Feed to the nearest end of the Power Distribution Housing.

**Note: If it is not practical to have a Power Distribution Housing in a panel adjacent to the selected Ceiling Feed Post, use a BE8CPxxHJ Housing-to-Jumper Pass-Thru Cable to transition through the adjacent non-powered panel(s) that are between the Ceiling Feed Post and the first powered panel. The length of the cable will equal the combined width of the non-powered panel(s).**

- c. At the base of an adjoining panel:
  - i. Use a BE83BFR72 Raceway Entry Base Feed
  - ii. Select a non-powered panel adjacent to the panel with a Power Distribution Housing.
  - iii. Choose a duplex opening on either side of the panel to insert and attach the Raceway Entry Base Feed at that point.
  - iv. The Raceway Entry Base Feed will attach to the nearest end of the Power Distribution Housing (similar to the Ceiling Feed attachment).

**STEP 2:** Determine which panels are to be powered.

- a. Use a BE83D Power Distribution Housing that corresponds with the width of the selected panel.

**STEP 3:** Connect power to the panels.

- a. Use a BE8JC16 Jumper between two adjacent powered panels.
- b. Use a BE8JC20 Jumper between two powered panels separated by a post.
- c. Use a BE8CPxxHH Housing-to-Housing Pass-Thru Cable to connect two powered panels separated by one or more non-powered panels. i. The length of the Pass-Thru Cable corresponds with the width(s) of the non-powered panels that separate two powered panels plus 16" (the termination blocks of the Power Distribution Housing are 8" in from the edge of the powered panel plus 4" for each post).

**STEP 4:** Designate which circuit each duplex is to tap into.

- a. Each powered panel has four (4) potential locations for duplex receptacles - 2 per side. (Exception: 24" wide panel has only two (2) potential locations - 1 per side, 18" wide panel has no locations for receptacles).
- b. At each location there is a choice of four (4) circuit options. Select the circuit option for each location.

**Circuit Selections : Circuits 1, 2, and 3 are utility circuits, all sharing a ground and a neutral. Circuit A is a dedicated circuit with its own ground and neutral.**

**SPECIFICATION APPLICATIONS**

**Boulevard System 3 Jumper Applications**

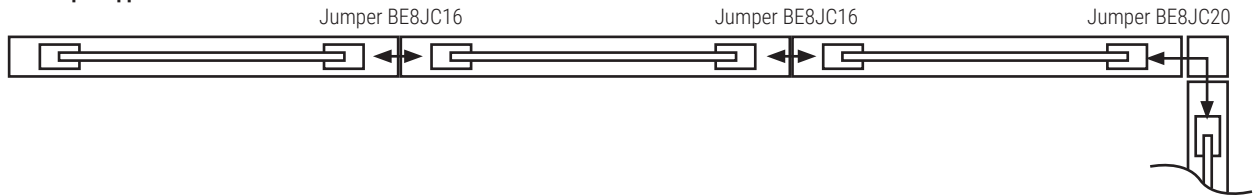

**Boulevard System 3 Jumper Applications**

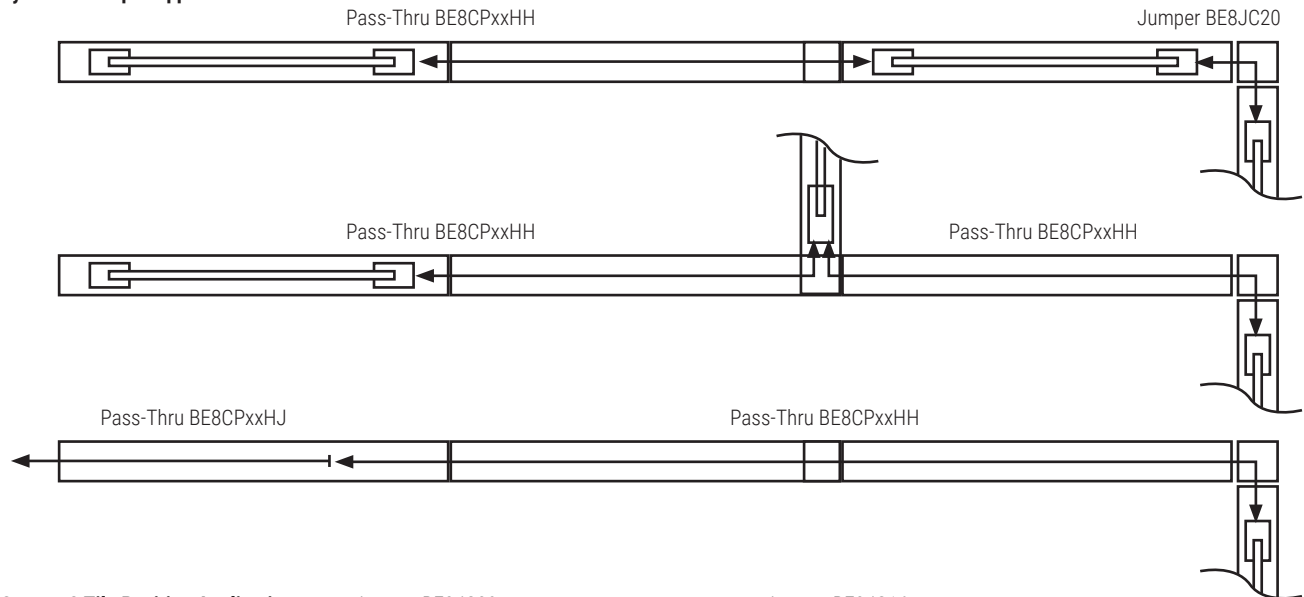

**Boulevard System 3 Tile Position Application**

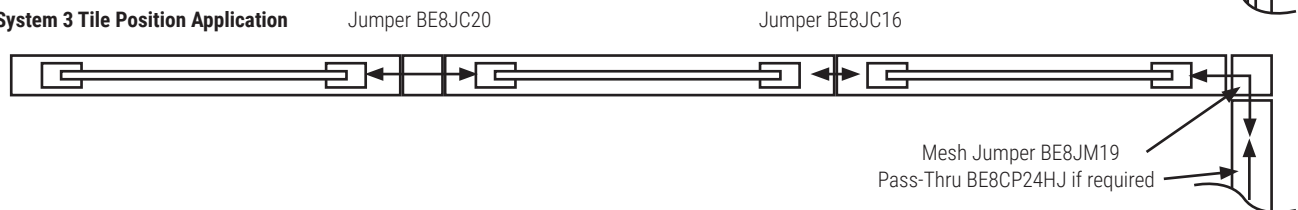



**BE8CI-1 • "I" Connector**

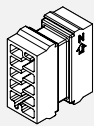

- Connects two Pass-Thru Cables.
- Inline coupler used to connect two BE8CPxxHH Pass-Thru Cables.

PRODUCT CODE	PRICE	SIZE / INCHES			WEIGHT VOL	
		H	W	D	LBS	FT <sup>3</sup>
BE8CI1	70	1.5	1.5	4.625	0.06	0.03

**BE8D • Duplex Receptacles**

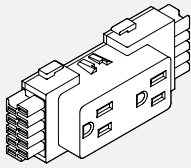

- Snaps into Power Distribution Housing.
- Up to 6 duplex receptacles per circuit.
- BE8D1 = Circuit #1 (utility circuit)
- BE8D2 = Circuit #2 (utility circuit)
- BE8D3 = Circuit #3 (utility circuit)
- BE8DA - Circuit #A (dedicated circuit)

PRODUCT CODE	PRICE	SIZE / INCHES			WEIGHT VOL	
		H	W	D	LBS	FT <sup>3</sup>
BE8D1	32	2	4.625	1.25	0.10	0.01
BE8D2	32	2	4.625	1.25	0.10	0.01
BE8D3	32	2	4.625	1.25	0.10	0.01
BE8DA	32	2	4.625	1.25	0.10	0.01

**BE8D • USB Receptacles**

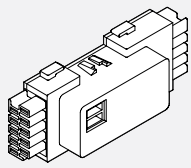

- Snaps into Power Distribution Housing.
- USB charging module provides convenient charging power access through dual ports on face of receptacles.
- Two USB ports.
- 2 amp output, considered as circuit #1.

PRODUCT CODE	PRICE	SIZE / INCHES			WEIGHT VOL	
		H	W	D	LBS	FT <sup>3</sup>
BE8DU1-B	269	2	4.625	1.25	0.10	0.01
BE8DU1-W	269	2	4.625	1.25	0.10	0.01

**BE83BF • Reversible Base Feed (Boulevard System 3 Only)**

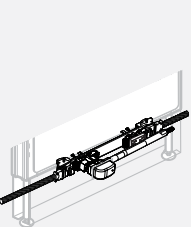

- Provides single power entry from floor circuit to raceway.
- Takes the place of a duplex receptacle by connecting to the base raceway channel of a Boulevard System 3 panel.
- BE83BF72 includes 72" long liquid-tight conduit, BE83BF144 includes 144" long liquid-tight conduit.
- Must be hard wired to power source by a licensed electrician.

PRODUCT CODE	PRICE	SIZE / INCHES			WEIGHT VOL	
		H	L	D	LBS	FT <sup>3</sup>
BE83BF72	314	3	72	3	3.82	2
BE83BF144	422	3	144	3	6.98	2

**BE83BFR72 • Raceway Entry Base Feed (Boulevard System 3 Only)**

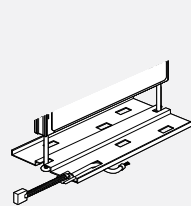

- Brings power to an adjacent panel by entering a non-powered raceway of a Boulevard System 3 panel through a duplex opening.
- Includes 72" long liquid-tight conduit.
- Must be hard wired to power source by a licensed electrician.

PRODUCT CODE	PRICE	SIZE / INCHES			WEIGHT VOL	
		H	L	D	LBS	FT <sup>3</sup>
BE83BFR72	446	3	88	3	4.82	2

**BE8CF-1 • Ceiling Feed - Single**

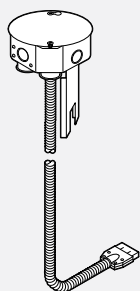

- Provides single power entry from ceiling, through post and into raceway channel.
- Power entry cable penetrates 8" into a panel and plugs into either a Power Distribution Housing or BE8CPxxHJ Pass-Thru Harness.
- Specify Post Extension separately.
- Must be hard wired to power source by a licensed electrician.

PRODUCT CODE	PRICE	SIZE / INCHES			WEIGHT VOL	
		H	L	D	LBS	FT <sup>3</sup>
BE8CF1201	308	6	120	6	5.24	2
BE8CF1441	349	6	144	6	5.96	2

**BE8CF-2 • Ceiling Feed - Double**

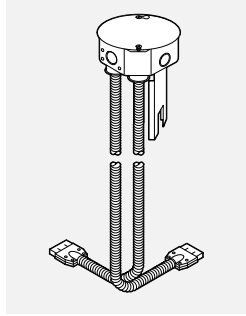

- Provides dual power entry from ceiling, through post and into raceway channel.
- Power entry cable penetrates 8" into a panel and plugs into either a Power Distribution Housing or a BE8CPxxHJ Pass-Thru Harness.
- Use 1) In middle of run to distribute power in two directions.  
2) At beginning of run where second Ceiling Feed harness is connected to BE8CPxxHJ and distributes power underneath Power Distribution Housing to pick-up second circuit grouping in long panel run.
- Specify Post Extension separately.
- Must be hard wired to power source by a licensed electrician.

PRODUCT CODE	PRICE	SIZE/INCHES			WEIGHT VOL	
		H	L	D	LBS	FT <sup>3</sup>
BE8CF1202	632	6	120	3	5.24	2
BE8CF1442	712	6	144	3	5.96	2

**BE81BF-1 • Base Feed - Single (Boulevard 1 Only)**

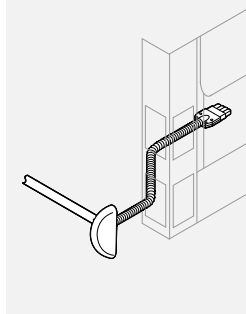

- Provides single power entry from floor, through post and into Boulevard 1 raceway channel.
- Power entry cable penetrates 8" into a panel and plugs into either a Power Distribution Housing or a BE8CPxxHJ Pass-Thru Harness.
- Power entry dome available in black only, but "Capture Strip" connector will match the post color as standard.
- 2 1/2" clearance in depth and 5 1/2" away from any obstructions required from power entry point.
- Comes with 32" harness attached. Liquid-tight whip 72" and 144".
- Must be hard wired to power source by a licensed electrician.

PRODUCT CODE	PRICE	SIZE/INCHES			WEIGHT VOL	
		H	L	D	LBS	FT <sup>3</sup>
BE81BF721	357	6	107	3	3.82	2
BE81BF1441	475	6	179	3	5.96	2

**BE81BF-1FL • Base Feed - Single (Boulevard 1 Only)**

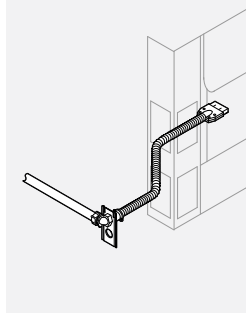

- Provides single power entry from floor, through post and into Boulevard 1 raceway channel.
- Power entry cable penetrates 8" into a panel and plugs into either a Power Distribution Housing or a BE8CPxxHJ Pass-Thru Harness.
- Power entry plate available in black only, but "Capture Strip" connector will match the post color as standard.
- 2 1/2" clearance in depth and 5 1/2" away from any obstructions required from power entry point.
- Comes with 32" harness attached. Liquid-tight whip 72" and 144".
- Must be hard wired to power source by a licensed electrician.

PRODUCT CODE	PRICE	SIZE/INCHES			WEIGHT VOL	
		H	L	D	LBS	FT <sup>3</sup>
BE81BF721FL	357	6	107	3	3.82	2
BE81BF1441FL	475	6	179	3	3.82	2

**BE81BF-2 • Base Feed - Double (Boulevard 1 Only)**

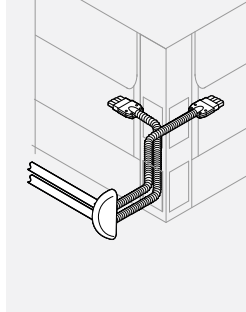

- Provides dual power entry from floor, through post and into Boulevard 1 raceway channel.
- Power entry cable penetrates 8" into a panel and plugs into either a Power Distribution Housing or a BE8CPxxHJ Pass-Thru Harness.
- Use 1) In middle-of-run to distribute power in two directions.  
2) At beginning of run where second Base Feed Harness is connected to BE8CPxxHJ and distributes power underneath Power Distribution Housing to pick-up second circuit grouping in long panel run.
- Liquid-tight whip 72" and 144".
- Power entry box available in black only, but "Capture Strip" connector will match the post color as standard.
- 2 1/2" clearance in depth and 5 1/2" away from any obstructions required from power entry point.
- Comes with 32" harness attached.
- Must be hard wired to power source by a licensed electrician.

PRODUCT CODE	PRICE	SIZE/INCHES			WEIGHT VOL	
		H	L	D	LBS	FT <sup>3</sup>
BE81BF722	756	6	107	3	6.98	2
BE81BF1442	1004	6	179	3	6.98	2

**BE81BF601 • Base Feed - Single (Boulevard 1 Only)**

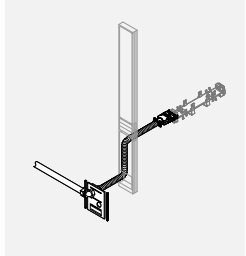

- Provides single power entry from floor, through 6" panel and into Boulevard 1 raceway panel.
- Power entry cable penetrates 8" into a panel and plugs into either a Power Distribution Housing or a BE8CPxxHJ Pass-Thru Harness.
- For 6" Power/Cable Access Panel only.
- Comes with 32" harness attached.
- Liquid-tight whip 72".
- Must be hard wired to power source by a licensed electrician.

PRODUCT CODE	PRICE	SIZE/INCHES			WEIGHT VOL	
		H	L	D	LBS	FT <sup>3</sup>
BE81BF601	385	6	107	3	4.90	0.062

**BE81BF602 • Base Feed - Double (Boulevard 1 Only)**

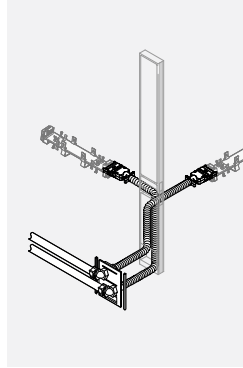

- Provides dual power entry from floor, through 6" panel and into Boulevard 1 raceway panel.
- Power entry cable penetrates 8" into a panel and plugs into either a Power Distribution Housing or a BE8CPxxHJ Pass-Thru Harness.
- Use 1. In middle-of-run to distribute power in two directions.
  2. At beginning of run where second Base Feed Harness is connected to BE8CPxxHJ and distributes power underneath Power Distribution Housing to pick-up second circuit grouping in long panel run.
- For 6" Power/Cable Access Panel only.
- Comes with 2" x 32" harness attached.
- Liquid-tight whip 72".
- Must be hard wired to power source by a licensed electrician.

PRODUCT CODE	PRICE	SIZE/INCHES			WEIGHT VOL	
		H	L	D	LBS	FT <sup>3</sup>
BE81BF602	775	6	107	3	5.30	0.071

**BE8JC • Jumper Cable**

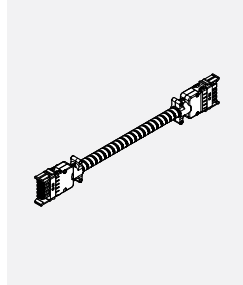

- Electrically connects two Power Distribution Housings.
- The BE8JC16 electrically connects two powered panels positioned side by side.
- The BE8JC20 electrically connects two powered panels separated by a post.
- Wires are concealed in a flexible metal conduit.
- Cannot go through a Boulevard 1 post in a corner application. (Please use the Jumper Cable Mesh)

PRODUCT CODE	PRICE	SIZE/INCHES			WEIGHT VOL	
		H	L	D	LBS	FT <sup>3</sup>
BE8JC16	130	2	16.75	0.5	0.66	1.17
BE8JC20	136	2	20.75	0.5	0.78	1.17

**BE8JM19 • Jumper Cable Mesh**

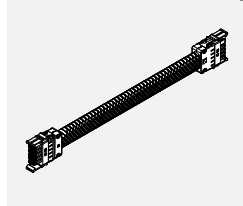

- Electrically connects two Power Distribution Housings in Boulevard 1 panels that are separated by a post in a corner application.
- BE8JM19 - Wires are covered with a durable nylon mesh.
- BE8JMS19 - Wires are concealed in a flexible metal shroud and covered with a durable nylon mesh.
- Used in System 3 Panels at tile position passing through post at corner application.

PRODUCT CODE	PRICE	SIZE/INCHES			WEIGHT VOL	
		H	L	D	LBS	FT <sup>3</sup>
BE8JM19	108	2	19	0.5	0.75	1.17
BE8JMS19	140	2	19	0.5	0.75	1.17

**BE83BT • Base-to-Tile Cable**

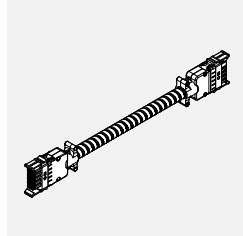

- Electrically connects a Base Raceway Power Distribution Housing to a Face-Mount Tile Power Distribution Housing within a System 3 PV panel.
- Wires are concealed in a flexible metal conduit.
- BE83BT82 to be used on panels manufactured before November 1st, 2014 and BE83BT40 after.

PRODUCT CODE	PRICE	SIZE/INCHES			WEIGHT VOL	
		H	L	D	LBS	FT <sup>3</sup>
BE83BT82	199	2	82.5	0.5	3.05	1.38
BE83BT40	179	2	40.5	0.5	1.44	1.17

**BE8CP-HH • Housing-to-Housing Pass-Thru Cable**

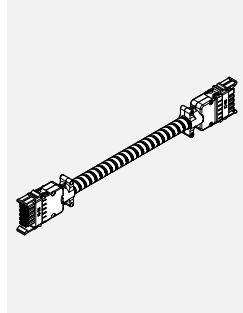

- Electrically connects two Power Distribution Housings in panels separated by one or more non-powered panels.
- Wires are concealed in a flexible metal conduit.
- NOTE : In Boulevard 1 and or System 3 tile position applications, the Housing-to-Housing Pass-Thru Cables can only be used in a straight run.

PRODUCT CODE	PRICE	SIZE/INCHES			WEIGHT VOL	
		H	L	D	LBS	FT <sup>3</sup>
BE8CP40HH	163	2	40.5	0.5	1.44	1.17
BE8CP46HH	171	2	46.5	0.5	1.71	1.17
BE8CP52HH	178	2	52.5	0.5	1.95	1.17
BE8CP58HH	187	2	58.5	0.5	2.21	1.17
BE8CP64HH	194	2	64.5	0.5	2.37	1.17
BE8CP70HH	201	2	70.5	0.5	2.6	1.17
BE8CP76HH	209	2	76.5	0.5	2.81	1.17
BE8CP82HH	215	2	82.5	0.5	3.03	1.17
BE8CP88HH	222	2	88.5	0.5	3.05	1.17
BE8CP94HH	230	2	94.5	0.5	3.30	1.17
BE8CP100HH	237	2	100.5	0.5	3.47	1.17
BE8CP106HH	247	2	106.5	0.5	3.87	1.17
BE8CP118HH	260	2	118.5	0.5	4.08	1.17
BE8CP130HH	275	2	130.5	0.5	4.73	1.17
BE8CP142HH	290	2	142.5	0.5	4.99	1.17

**BE8CP-HJ • Housing-to-Jumper Pass-Thru Cable**

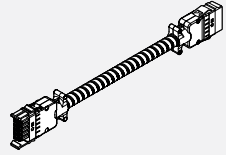

- Electrically connects a Power Distribution Housing to a Housing connection of a harness.
- Wires are concealed in a flexible metal conduit.
- NOTE : In both Boulevard 1 and System 3 Tile Position applications, the Housing-to-Jumper Pass-Thru Cables can only be used in a straight run.

PRODUCT CODE	PRICE	SIZE/INCHES			WEIGHT VOL	
		H	L	D	LBS	FT <sup>3</sup>
BE8CP24HJ	125	2	24	0.5	0.9	1.17
BE8CP30HJ	134	2	30	0.5	1.3	1.17
BE8CP36HJ	140	2	36	0.5	1.44	1.17
BE8CP42HJ	146	2	42	0.5	1.71	1.17
BE8CP48HJ	153	2	48	0.5	1.95	1.17
BE8CP54HJ	158	2	54	0.5	2.21	1.17
BE8CP60HJ	163	2	60	0.5	2.37	1.17
BE8CP72HJ	174	2	72	0.5	2.81	1.17
BE8CP84HJ	190	2	84	0.5	3.05	1.17
BE8CP96HJ	203	2	96	0.5	3.3	1.17
BE8CP108HJ	215	2	108	0.5	3.87	1.17
BE8CP120HJ	228	2	120	0.5	4.08	1.17
BE8CP144HJ	242	2	144	0.5	4.59	1.17

**BE81D • Power Distribution Housing Kit - Concealed Desk Height (Boulevard 1 Only)**

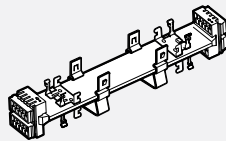

- Provides two duplex receptacles per panel for all panel widths above 24" wide.
- Power Distribution Housing is specified per panel size. eg. BE81D36 is for use with a 36" panel.

PRODUCT CODE	PRICE	SIZE/INCHES			WEIGHT VOL	
		H	L	D	LBS	FT <sup>3</sup>
BE81D24	134	2	9.25	2.61	0.83	1.17
BE81D30	166	2	15.25	2.61	1.28	1.17
BE81D36	174	2	21.25	2.61	1.62	1.65
BE81D42	188	2	27.25	2.61	2.00	2.00
BE81D48	198	2	33.25	2.61	2.32	2.54
BE81D54	207	2	39.25	2.61	2.66	3.20
BE81D60	212	2	45.25	2.61	3.04	3.20
BE81D66	368	2	51.25	2.61	3.49	3.25
BE81D72	368	2	57.2	2.61	3.76	3.30

**BE8U2D • Power Distribution Housing Kit - Face-Mount Desk Height (Boulevard 1 Only)**

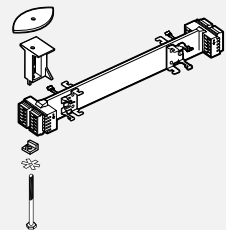

- Provides two duplex receptacles per panel side for all panel widths above 24" wide.
- Power Distribution Housing is specified per panel size. eg. BE8U2D36 is for use with a 36" panel.
- 24" wide panel allows for only one (1) duplex receptacle per panel side.

PRODUCT CODE	PRICE	SIZE/INCHES			WEIGHT VOL	
		H	L	D	LBS	FT <sup>3</sup>
BE8U2D24	166	2	9.25	2.61	0.83	1.17
BE8U2D30	191	2	15.25	2.61	1.28	1.17
BE8U2D36	201	2	21.25	2.61	1.62	1.65
BE8U2D42	212	2	27.25	2.61	2.00	2.00
BE8U2D48	221	2	33.25	2.61	2.32	2.54
BE8U2D54	231	2	39.25	2.61	2.66	3.20
BE8U2D60	237	2	45.25	2.61	3.04	3.20
BE8U2D66	368	2	51.25	2.61	3.49	3.25
BE8U2D72	368	2	57.25	2.61	3.76	3.30

**BE83D • Power Distribution Housing Kit - Base Raceway (Boulevard System 3 Only)**

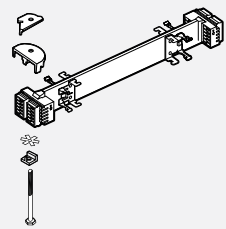

- Provides two duplex receptacles per panel side for all panel widths above 24" wide.
- Power Distribution Housing is specified per panel size. eg. BE83D36 is for use with a 36" panel.
- 24" wide panel allows for only one (1) duplex receptacle per panel side.

PRODUCT CODE	PRICE	SIZE/INCHES			WEIGHT VOL	
		H	L	D	LBS	FT <sup>3</sup>
BE83D24	166	2	9.25	2.61	0.83	1.17
BE83D30	191	2	15.25	2.61	1.28	1.17
BE83D36	201	2	21.25	2.61	1.62	1.65
BE83D42	212	2	27.25	2.61	2.00	2.00
BE83D48	221	2	33.25	2.61	2.32	2.54
BE83D54	228	2	39.25	2.61	2.66	3.20
BE83D60	237	2	45.25	2.61	3.04	3.20
BE83D66	368	2	51.25	2.61	3.49	3.25
BE83D72	368	2	57.25	2.61	3.76	3.30

**BE8U3FM • Power Distribution Housing Kit - Face-Mount Tile (Boulevard System 3 Only)**

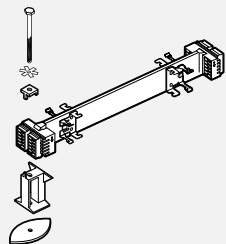

- Provides two duplex receptacles for all tile widths above 24". 24" wide tile allows for one (1) duplex receptacle.
- Housing and mounting hardware included.
- Specify duplexes, cables and tiles separately.
- BE83BT40 Base-to-Tile Cable is used to connect the tile mounted housing to the Power Distribution Housing tile in the base of the same "PV" panel.
- 24" wide tiles have one duplex and one data/comm opening. 30" and wider tiles have two data/comm openings.
- Note: Not compatible with panels built prior November 1st, 2014.

PRODUCT CODE	PRICE	SIZE/INCHES			WEIGHT VOL	
		H	L	D	LBS	FT <sup>3</sup>
BE8U3FM24	166	2	9.25	2.61	0.83	1.17
BE8U3FM30	191	2	15.25	2.61	1.28	1.17
BE8U3FM36	201	2	21.25	2.61	1.62	1.65
BE8U3FM42	212	2	27.25	2.61	2.00	2.00
BE8U3FM48	221	2	33.25	2.61	2.32	2.54
BE8U3FM54	228	2	39.25	2.61	2.66	3.20
BE8U3FM60	237	2	45.25	2.61	3.04	3.20
BE8U3FM66	368	2	51.25	2.61	3.49	3.25
BE8U3FM72	368	2	57.25	2.61	3.76	3.30

**BE81D-CM • Center Mount Power Distribution Housing Quad Kit - Concealed Desk Height (B1 Only)**

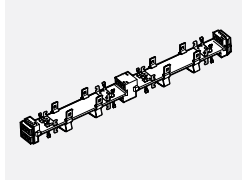

- Provides four duplex receptacles per panel for widths 36" and above.
- Center Mount Distribution Housing is specified per panel size. ie. BE81D36CM is for 36" panel.
- Not available for panels less than 36" wide.

PRODUCT CODE	PRICE	SIZE/INCHES			WEIGHT VOL	
		H	L	D	LBS	FT <sup>3</sup>
BE81D36CM	299	2	21.99	2.61	3.24	1.65
BE81D42CM	352	2	27.99	2.61	4.00	2.00
BE81D48CM	368	2	33.99	2.61	4.64	2.54
BE81D54CM	384	2	39.99	2.61	5.32	3.20
BE81D60CM	403	2	45.99	2.61	6.04	3.20
BE81D66CM	551	2	51.99	2.61	6.98	3.25
BE81D72CM	571	2	57.99	2.61	7.52	3.30

**BEPE • Post Extension**

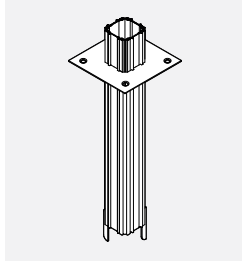

- Lightweight aluminum pole to be used to bring power and/or data/communication cables from ceiling to a panel through a post.
- Attaches to ceiling and post.
- Includes connectors, ceiling trim plate and screws.
- Post extension will accept:
  - 75 cables 5.6 mm (0.220") dia. data cables
  - 60 cables 5.6 mm (0.220") dia. data cables with 1 power feed
  - 45 cables 5.6 mm (0.220") dia. data cables with 2 power feeds.
- Ceiling bezel is white only.

PRODUCT CODE	PRICE	SIZE/INCHES			WEIGHT VOL	
		L	D	LBS	FT <sup>3</sup>	
BEPE49	95	49	2.61	5.00	0.258	
BEPE81	144	81	2.61	9.00	0.424	

**BHPOST • Lay-In Post Extension**

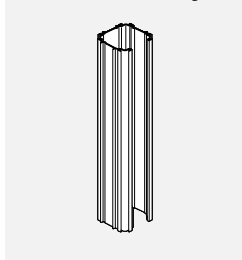

- Three sided lightweight aluminum pole to be used to bring power and/or data/communication cables from ceiling to a panel. True lay-in application use
- Attaches to ceiling and post.
- Includes connectors and ceiling bezel plate and screws.
- Requires vertical end trim to enclose when used in 2 way and 3 way panel run application.
- Trim encloses lay-in cable post extension, sold separately.

PRODUCT CODE	PRICE	TYPE	SIZE/INCHES			WEIGHT VOL	
			H	L	D	LBS	FT <sup>3</sup>
BHPOST66	209	BASE	66	2.61	2.61	8	0.346
BHPOSTE30	71	EXTENSION	30	2.61	2.61	5	0.195
BHPOSTE78	179	EXTENSION	78	2.61	2.61	9	0.430

**BE2PE • Off-Module Post Extension**

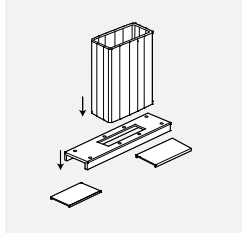

- An alternative to the existing Ceiling Post, allows for an off-module Ceiling Feed location.
- Attaches to the top of horizontal trim.
- Panel ceiling post consists of two aluminum extrusions for a true lay-in application.
- Includes brackets, hardware and ceiling trim plate and screws.
- Harness length will vary in length depending on post location along the panel.
- Can only be used with Boulevard System 3 "PV" and "MV" Panels.
- Requires on site cutting of top trim for placement along panel.

PRODUCT CODE	PRICE	SIZE/INCHES			WEIGHT VOL	
		H	L	D	LBS	FT <sup>3</sup>
BE2PE49	214	49	7.61	3.00	5	0.258
BE2PE81	318	81	7.61	3.00	9	0.424

**DEK • Jumper Harness**

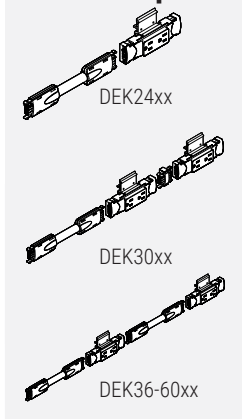

- Kit includes all components to add power to Diet Panels.
- Typical kit includes: 2 Duplex Receptacle Blocks (either circuit #1 or circuit #2), the Jumper Harness between the Duplex Receptacle Blocks, the Jumper Harness to the next panel, the pre-punched Raceway Cover, the aluminum Raceway Junction Cover, 2 PVC Duplex Receptacle Block Spacers and the hardware to attach the components.
- The length of the Jumper Harness between two Duplex Receptacle Blocks is based on the panel width.
- Jumper Harness going into the next panel and the aluminum Raceway Junction Covers are standard size.
- Raceway Cover and Raceway Junction Cover are Charcoal (CHR) only.
- Each kit is identified as circuit #1 (ie. DEK240"1") or circuit #2 (ie. DEK240"2").
- 24" wide panels have a single Duplex Receptacle Block only.
- 30" wide panels have 2 Duplex Receptacle Blocks, however they must be facing the same direction.
- 24" and 30" wide panels are not pre-punched for data.
- 36" to 60" wide panels are pre-punched for Duplex Receptacle Blocks on either side and for data just off-center on both sides.

PRODUCT CODE	PRICE	SIZE/INCHES			WEIGHT VOL	
		H	W	D	LBS	FT <sup>3</sup>
DEK2401	266	4	18	1.3	4.90	0.07
DEK3001	389	4	24	1.3	5.25	0.08
DEK3601	408	4	30	1.3	5.70	0.10
DEK4201	422	4	36	1.3	6.00	0.13
DEK4801	441	4	42	1.3	6.40	0.15
DEK5401	463	4	48	1.3	7.10	0.16
DEK6001	481	4	54	1.3	7.60	0.19
DEK2402	266	4	18	1.3	4.90	0.07
DEK3002	389	4	24	1.3	5.25	0.08
DEK3602	408	4	30	1.3	5.70	0.10
DEK4202	422	4	36	1.3	6.00	0.13
DEK4802	441	4	42	1.3	6.40	0.15
DEK5402	463	4	48	1.3	7.10	0.16
DEK6002	481	4	54	1.3	7.60	0.19

**DEJH • Diet Pass-Thru Kit**

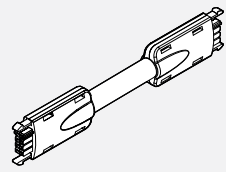

- Kit allows electrical to pass through a Diet Panel.
- Kit includes: female-female jumper harness, Raceway Cover and Raceway Junction Cover.
- Pass-Thru harness connects to a Duplex Receptacle Block within one powered panel; passes through a non-powered panel, and the opposite end connects to another Receptacle Block within the second powered panel.
- Raceway Cover and Raceway Junction Cover are Charcoal (CHR) only.

PRODUCT CODE	PRICE	SIZE/INCHES			WEIGHT VOL	
		H	L	D	LBS	FT <sup>3</sup>
DEJH24	182	2	42	1	1.81	0.025
DEJH30	207	2	48	1	2.07	0.028
DEJH36	226	2	54	1	2.12	0.032
DEJH42	245	2	60	1	2.60	0.035
DEJH48	263	2	66	1	2.86	0.038
DEJH54	284	2	72	1	3.13	0.041
DEJH60	301	2	78	1	3.39	0.044

**DEBF • Diet Base Feed**

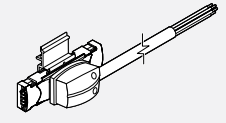

- Provides single power entry from floor into raceway.
- Single Ceiling Feed has a 6' whip, liquid tight.
- Raceway connection replaces one Duplex Receptacle Block in a standard kit.

PRODUCT CODE	PRICE	SIZE/INCHES			WEIGHT VOL	
		H	L	D	LBS	FT <sup>3</sup>
DEBF01	228	2	72	2	5.6	0.06

**DECF • Diet Ceiling Feed**

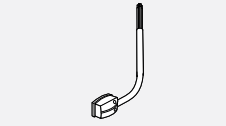

- Provides single power entry from ceiling through a post into raceway.
- Raceway connection replaces one Duplex Receptacle Block in a standard kit.

PRODUCT CODE	PRICE	SIZE/INCHES			WEIGHT VOL	
		H	L	D	LBS	FT <sup>3</sup>
DECF01	371	2	144	2	5.6	0.06

**DEPE • Diet Post Extension**



- Lightweight aluminum pole manages power and data cables between ceiling and floor level raceway.
- Aluminum extrusion with PVC extruded cover secures to the outside of the panel and passes through the worksurface scoop.
- Includes all hardware and bezel.
- Intended for use on Diet panels with fabric bottoms.

PRODUCT CODE	PRICE	SIZE/INCHES			WEIGHT VOL	
		H	W	D	LBS	FT <sup>3</sup>
DEPE116	255	116	4.5	1	7	0.82

**DERJC • Raceway Junction Cover**

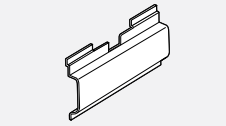

- Provides an external cover for cables passing between adjacent, in-line panels and off-module "X" panel configurations. Also, capable of bridging two in-line panels in a "T" configuration (outside).
- Aluminum, powder coated finish.

PRODUCT CODE	PRICE	SIZE/INCHES			WEIGHT VOL	
		H	W	D	LBS	FT <sup>3</sup>
DERJC	25	4.3	10	1	0.5	0.1

**WORKSURFACES**

Teknion offers a wide variety of worksurfaces and user friendly worksurface shapes to support a variety of tasks, applications and personal preferences.

High and Low pressure worksurfaces are 3 mm edge banded.  
Wood veneer surfaces or solid wood edges available.

1 1/16" particle board.

45 lb. density

100% recycled from post consumer industrial material

"Scoops" for cable management.

All worksurfaces have threaded inserts for metal-to-metal connection of support hardware.

**TECHNICAL INFORMATION****Worksurfaces**

All worksurfaces have threaded inserts for metal-to-metal connection of support hardware.

Back edge features scoop detail.

Worksurfaces 48" or less have one scoop while those that are 54" or more have a double scoop feature with a 1/2" wire passage trough between the scoops.

LP and HP worksurfaces are 3 mm edge banded.

LP worksurfaces are 1" thick particle board with laminate finish.

HP worksurfaces are 1 1/16" thick particle board with laminate finish.

T worksurfaces are 1 1/16" thick particle board with laminate finish and wood trim.

W worksurfaces are 1 3/16" thick particle board with wood veneer finish. Edge is solid wood edge banded.

One universal cantilever supports two abutting worksurfaces.

20" deep worksurfaces available at same price as 24" deep worksurfaces.

Support hardware must be ordered separately.

Edge banded worksurfaces without scoops available, substitute "NFL" for "SCP" at the end of the code.

**Transaction Worksurfaces**

To install transaction worksurfaces to a 42" high panel, use BHBT02 bracket.

To install transaction worksurfaces to a 37" high panel, use BHBT37 bracket.

**BWS • Straight Rectangular Worksurface With Scoop**

- Straight rectangular worksurfaces are non-handed and can be interchanged on site.
- Please choose from DWT - Designer White, SIL - Silver or BLK - Black for scoop covers.

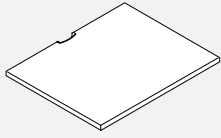

Worksurfaces 54" or Less

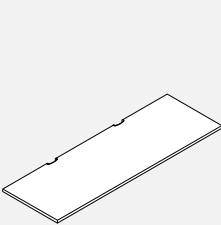

Worksurfaces 60" or Longer

PRODUCT CODE	PRICE LP*	GROUP			SIZE / INCHES				WEIGHT VOL	
		HP*	T*	W*	H	W	D	LBS	FT <sup>3</sup>	
BWS1818P	119	151	218	331	1	18	18	9	0.29	
BWS1824P	130	163	244	409	1	24	18	12	0.39	
BWS1830P	139	173	258	498	1	30	18	15	0.49	
BWS1836P	157	196	288	587	1	36	18	18	0.59	
BWS1842P	209	258	361	706	1	42	18	21	0.68	
BWS1848P	247	308	414	741	1	48	18	24	0.78	
BWS1854P	287	361	475	754	1	54	18	27	0.88	
BWS1860P	318	395	518	778	1	60	18	30	1.00	
BWS1866P	339	423	552	802	1	66	18	32	1.10	
BWS1872P	357	446	588	826	1	72	18	35	1.20	
BWS1878P	377	471	621	898	1	78	18	38	1.30	
BWS1884P	409	511	676	937	1	84	18	41	1.40	
BWS2418P	123	155	244	382	1	18	24	12	0.40	
BWS2424P	134	166	258	473	1	24	24	16	0.52	
BWS2430P	141	176	277	579	1	30	24	20	0.65	
BWS2436P	161	201	312	676	1	36	24	23	0.78	
BWS2442P	210	261	378	810	1	42	24	28	0.90	
BWS2448P	252	314	437	898	1	48	24	31	1.03	
BWS2454P	295	368	503	923	1	54	24	35	1.20	
BWS2460P	333	414	554	946	1	60	24	39	1.30	
BWS2466P	345	433	581	986	1	66	24	43	1.41	
BWS2472P	362	452	605	1021	1	72	24	47	1.54	
BWS2478P	384	480	652	1124	1	78	24	51	1.70	
BWS2484P	414	518	697	1213	1	84	24	55	1.80	
BWS3018P	144	178	280	475	1	18	30	15	0.50	
BWS3024P	155	194	302	594	1	24	30	20	0.70	
BWS3030P	168	211	330	702	1	30	30	25	0.97	
BWS3036P	198	248	372	831	1	36	30	30	1.06	
BWS3042P	280	350	477	870	1	42	30	34	1.12	
BWS3048P	295	368	509	939	1	48	30	39	1.30	
BWS3054P	323	405	552	975	1	54	30	44	1.44	
BWS3060P	345	433	587	1014	1	60	30	49	1.60	
BWS3066P	361	448	612	1092	1	66	30	54	1.80	
BWS3072P	381	476	648	1176	1	72	30	59	2.00	
BWS3078P	404	504	686	1297	1	78	30	64	2.10	
BWS3084P	446	557	751	1398	1	84	30	69	2.24	
BWS3672P	724	949	1480	2373	1	72	36	71	2.30	

LP = Thermally Fused Laminate, HP = High Pressure Laminate, T= High Pressure Laminate with Wood Trim, W= Wood Veneer



**BWSP • Straight Rectangular Worksurface to Span a Post With Scoop**

- Straight rectangular worksurfaces are non-handed and can be interchanged on site.
- Worksurface will span the width of a post eliminating a gap between standard sizes.
- Please choose from DWT - Designer White, SIL - Silver or BLK - Black for scoop covers.

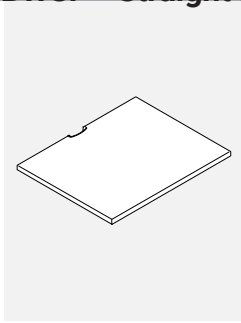

Worksurfaces 57" or Less

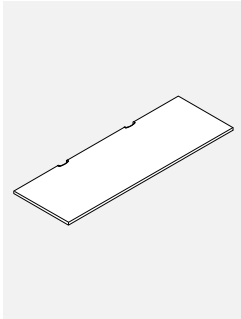

Worksurfaces 63" or Longer

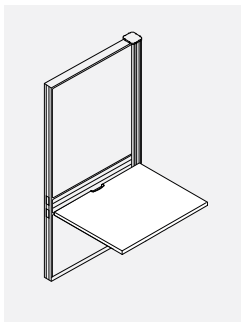

Application of Worksurface

PRODUCT CODE	PRICE LP*	GROUP			SIZE / INCHES			WEIGHT VOL	
		HP*	T*	W*	H	W	D	LBS	FT <sup>3</sup>
BWSP1821P	130	163	242	408	1	21	18	10	0.34
BWSP1827P	139	172	258	497	1	27	18	13	0.44
BWSP1833P	157	196	287	583	1	33	18	16	0.53
BWSP1839P	207	258	360	702	1	39	18	19	0.63
BWSP1845P	245	304	411	736	1	45	18	22	0.72
BWSP1851P	286	360	474	751	1	51	18	25	0.82
BWSP1857P	318	395	518	778	1	57	18	28	0.92
BWSP1863P	338	421	549	795	1	63	18	31	1.01
BWSP1869P	356	444	584	822	1	69	18	34	1.11
BWSP1875P	385	469	619	895	1	75	18	37	1.21
BWSP1881P	406	509	670	930	1	81	18	40	1.30
BWSP1887P	438	547	761	1038	1	87	18	43	1.40
BWSP2421P	134	166	258	473	1	21	24	14	0.45
BWSP2427P	141	176	277	579	1	27	24	17	0.60
BWSP2433P	161	201	312	676	1	33	24	21	0.70
BWSP2439P	210	261	378	810	1	39	24	25	0.83
BWSP2445P	252	314	437	898	1	45	24	29	1.00
BWSP2451P	295	368	503	923	1	51	24	33	1.10
BWSP2457P	333	414	554	946	1	57	24	37	1.22
BWSP2463P	345	433	581	986	1	63	24	41	1.34
BWSP2469P	362	452	605	1021	1	69	24	45	1.47
BWSP2475P	384	480	652	1124	1	75	24	49	1.60
BWSP2481P	414	518	697	1213	1	81	24	53	1.73
BWSP2487P	522	654	786	1295	1	87	24	57	1.90
BWSP3021P	155	194	302	594	1	21	30	17	0.56
BWSP3027P	168	211	330	702	1	27	30	22	0.72
BWSP3033P	198	248	372	831	1	33	30	27	0.88
BWSP3039P	280	350	477	870	1	39	30	32	1.04
BWSP3045P	295	368	509	939	1	45	30	37	1.20
BWSP3051P	323	405	552	975	1	51	30	41	1.40
BWSP3057P	345	433	587	1014	1	57	30	46	1.51
BWSP3063P	361	448	612	1092	1	63	30	51	1.67
BWSP3069P	381	476	648	1176	1	69	30	56	1.83
BWSP3075P	404	504	686	1297	1	75	30	61	2.00
BWSP3081P	446	557	751	1398	1	81	30	66	2.20
BWSP3087P	598	748	946	1501	1	87	30	70	2.30
BWSP3675P	741	972	1480	2373	1	75	36	73	2.40

LP = Thermally Fused Laminate, HP = High Pressure Laminate, T= High Pressure Laminate with Wood Trim, W= Wood Veneer

**BWS • Straight Rectangular Worksurface**

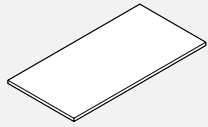

- Straight rectangular worksurfaces are non-handed and can be interchanged on site.
- Worksurface features no scoop or flex lip.

PRODUCT CODE	PRICE LP*	GROUP			SIZE/INCHES			WEIGHT VOL	
		HP*	T*	W*	H	W	D	LBS	FT <sup>3</sup>
BWS1818NFL	119	151	218	331	1	18	18	9	0.28
BWS1824NFL	130	163	244	409	1	24	18	12	0.40
BWS1830NFL	139	173	258	498	1	30	18	15	0.50
BWS1836NFL	157	196	288	587	1	36	18	18	0.59
BWS1842NFL	209	258	361	706	1	42	18	21	0.68
BWS1848NFL	247	308	414	741	1	48	18	24	0.78
BWS1854NFL	287	361	475	754	1	54	18	27	0.88
BWS1860NFL	318	395	518	778	1	60	18	29	0.97
BWS1866NFL	339	423	552	802	1	66	18	32	1.10
BWS1872NFL	357	446	588	826	1	72	18	35	1.20
BWS1878NFL	377	471	621	898	1	78	18	38	1.30
BWS1884NFL	409	511	676	937	1	84	18	41	1.40
BWS2418NFL	123	155	244	382	1	18	24	12	0.40
BWS2424NFL	134	166	258	473	1	24	24	16	0.52
BWS2430NFL	141	176	277	579	1	30	24	20	0.65
BWS2436NFL	161	201	312	676	1	36	24	24	0.78
BWS2442NFL	210	261	378	810	1	42	24	28	0.90
BWS2448NFL	252	314	437	898	1	48	24	31	1.03
BWS2454NFL	295	368	503	923	1	54	24	35	1.20
BWS2460NFL	333	414	554	946	1	60	24	39	1.30
BWS2466NFL	345	433	581	986	1	66	24	43	1.41
BWS2472NFL	362	452	605	1021	1	72	24	47	1.54
BWS2478NFL	384	480	652	1124	1	78	24	51	1.70
BWS2484NFL	414	518	697	1213	1	84	24	55	1.80
BWS3018NFL	144	178	280	475	1	18	30	15	0.50
BWS3024NFL	155	194	302	594	1	24	30	20	0.65
BWS3030NFL	168	211	330	702	1	30	30	25	0.81
BWS3036NFL	198	248	372	831	1	36	30	29	1.00
BWS3042NFL	280	350	477	870	1	42	30	34	1.13
BWS3048NFL	295	368	509	939	1	48	30	39	1.30
BWS3054NFL	323	405	552	975	1	54	30	44	1.44
BWS3060NFL	345	433	587	1014	1	60	30	49	1.60
BWS3066NFL	361	448	612	1092	1	66	30	54	1.76
BWS3072NFL	381	476	648	1176	1	72	30	59	1.91
BWS3078NFL	404	504	686	1297	1	78	30	64	2.10
BWS3084NFL	446	557	751	1398	1	84	30	69	2.24
BWS3672NFL	724	944	1118	1443	1	72	36	71	2.30

**BWSC • Curvelinair Front Edge Worksurface**

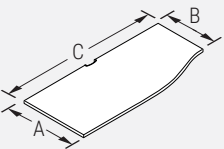

- Curvelinair front edge worksurface.
- Allows efficient use of a small footprint.
- The curve on the 30" and 36" wide worksurfaces have been modified to allow a pedestal to fit.
- Please choose from DWT - Designer White, SIL- Silver or BLK - Black for scoop covers.
- Surfaces 60" wide will have two scoops, all other have one scoop.

**NOTE: BWSC**

24	18	30
A	B	C
WIDTH	WIDTH	LENGTH

PRODUCT CODE	PRICE LP*	GROUP			SIZE/INCHES			WEIGHT VOL	
		HP*	T*	W*	H	W	D	LBS	FT <sup>3</sup>
BWSC182430P	179	222	355	711	1	30	24	18	0.65
BWSC182436P	215	271	404	898	1	36	24	22	0.78
BWSC182442P	252	314	458	898	1	42	24	26	0.90
BWSC182448P	287	361	508	970	1	48	24	30	1.03
BWSC182454P	323	405	561	1035	1	54	24	34	1.20
BWSC182460P	361	448	617	1081	1	60	24	38	1.30
BWSC241830P	179	222	355	711	1	30	24	18	0.65
BWSC241836P	215	271	404	789	1	36	24	22	0.78
BWSC241842P	252	314	458	898	1	42	24	26	0.90
BWSC241848P	287	361	508	970	1	48	24	30	1.03
BWSC241854P	323	405	561	1035	1	54	24	34	1.2
BWSC241860P	361	448	617	1081	1	60	24	38	1.3
BWSC243030P	188	236	367	802	1	30	30	23	0.81
BWSC243036P	215	271	408	868	1	36	30	28	1
BWSC243042P	311	385	540	1010	1	42	30	33	1.13
BWSC243048P	323	405	572	1081	1	48	30	38	1.3
BWSC243054P	361	447	626	1181	1	54	30	42	1.44
BWSC243060P	393	495	681	1227	1	60	30	47	1.6
BWSC302430P	188	236	367	802	1	30	30	23	0.81
BWSC302436P	215	271	408	868	1	36	30	28	1
BWSC302442P	311	385	540	1010	1	42	30	33	1.13
BWSC302448P	323	405	572	1081	1	48	30	38	1.3
BWSC302454P	361	447	626	1181	1	54	30	42	1.44
BWSC302460P	393	491	681	1226	1	60	30	47	1.6

LP = Thermally Fused Laminate, HP = High Pressure Laminate, T= High Pressure Laminate with Wood Trim, W= Wood Veneer

**BWCC • Curved-Corner Worksurface**

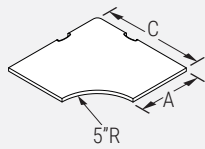

- Allows efficient use of corner space for computer or printer applications.
- BWCC3624 has a front radius of 12". It is not usable for keyboard support.
- Please choose from DWT - Designer White, SIL - Silver or BLK - Black for scoop covers.

**NOTE: BWCC**

36	18
C	A
WIDTH	DEPTH

PRODUCT CODE	PRICE LP*	GROUP HP*	T*	W*	SIZE/INCHES			WEIGHT VOL	
BWCC3618P	352	439	622	1198	1	36	36	29	1.20
BWCC3624P	387	484	792	1335	1	36	36	32	1.20
BWCC4224P	525	657	856	1407	1	42	42	41	1.60
BWCC4230P	538	671	853	1448	1	42	42	45	1.60
BWCC4824P	612	765	1019	1885	1	48	48	50	2.00
BWCC4830P	612	765	1019	1885	1	48	48	56	2.00

CODE	RADIUS "R"
BWCC3618P	18"
BWCC3624P	12"
BWCC4224P	18"
BWCC4230P	12"
BWCC4824P	24"
BWCC4830P	18"

NOTE: 12" radius not recommended for keyboards

**BWCF • Five-Sided Corner Worksurface**

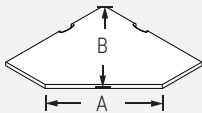

- Creates efficient use of corner space for computer or printer applications.
- Please choose from DWT - Designer White, SIL - Silver or BLK - Black for scoop covers.

PRODUCT CODE	PRICE LP*	GROUP HP*	T*	W*	SIZE/INCHES			WEIGHT VOL	
BWCF3012P	218	272	405	1045	1	30	30	28	1.00
BWCF3612P	303	378	487	1069	1	36	36	30	1.03
BWCF3618P	303	378	487	1069	1	36	36	31	1.20
BWCF3624P	318	395	504	1069	1	36	36	33	1.20
BWCF3630P	333	414	522	1069	1	36	36	35	1.20
BWCF4218P	433	540	664	1273	1	42	42	40	1.60
BWCF4224P	446	557	684	1273	1	42	42	45	1.60
BWCF4230P	462	576	702	1273	1	42	42	47	1.60
BWCF4818P	490	612	775	1474	1	48	48	40	1.60
BWCF4824P	506	628	790	1474	1	48	48	45	1.60
BWCF4830P	534	664	829	1474	1	48	48	47	1.60

CODE	PANEL SIZES	ADJOINED WORKSURFACE DEPTH	A	B
BWCF3012P	30	12	25.5	29.8
BWCF3612P	36	12	34.0	34.0
BWCF3618P	36	18	25.5	37.9
BWCF3624P	36	24	17.0	42.1
BWCF3630P	36	30	8.5	46.4
BWCF4218P	42	18	33.9	42.1
BWCF4224P	42	24	25.5	46.4
BWCF4230P	42	30	17.0	50.6
BWCF4818P	48	18	42.4	46.4
BWCF4824P	48	24	33.9	50.6
BWCF4830P	48	30	25.5	54.8

**BWCL • "L" Corner Worksurface**

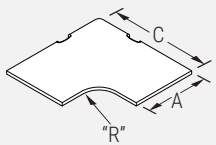

- Creates efficient use of corner space for computer or printer applications.
- Please choose from DWT - Designer White, SIL - Silver or BLK - Black for scoop covers.

**NOTE: BWCL**

5" radius not recommended for keyboards.

36	18
C	A
WIDTH	DEPTH

PRODUCT CODE	PRICE LP*	GROUP HP*	T*	W*	SIZE/INCHES			WEIGHT VOL	
BWCL3018P	218	270	372	1191	1	30	30	20	0.80
BWCL3024P	215	271	367	1191	1	30	30	23	0.80
BWCL3618P	318	395	508	1198	1	36	36	27	1.20
BWCL3624P	333	414	525	1198	1	36	36	31	1.20
BWCL3630P	345	433	544	1198	1	36	36	34	1.20
BWCL4218P	462	576	702	1407	1	42	42	32	1.60
BWCL4224P	476	594	719	1407	1	42	42	39	1.60
BWCL4230P	490	612	739	1407	1	42	42	44	1.60
BWCL4818P	504	628	790	1608	1	48	48	38	2.00
BWCL4824P	518	647	810	1608	1	48	48	47	2.00
BWCL4830P	531	664	829	1608	1	48	48	54	2.00

LP = Thermally Fused Laminate, HP = High Pressure Laminate, T= High Pressure Laminate with Wood Trim, W= Wood Veneer

**BWAC45 • Curved-Corner Worksurface for 45 Degree Angle**

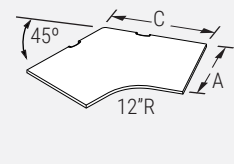

- Five-sided corner unit for 45 degree Corner Posts.
- Creates efficient use of space for computer or printer application.
- Please choose from DWT - Designer White, SIL - Silver or BLK - Black for scoop covers.

**NOTE: BWAC**

45°	24	18
	C	A
45° POST	WIDTH	DEPTH

PRODUCT CODE	PRICE LP*	GROUP HP*	T*	W*	SIZE/INCHES			WEIGHT VOL	
					H	W	D	LBS	FT <sup>3</sup>
BWAC452418P	352	439	628	1133	1	24	18	38	1.14
BWAC452424P	367	460	775	1398	1	24	24	42	1.29
BWAC452430P	382	476	992	1797	1	24	30	48	1.45
BWAC453018P	452	566	1356	1812	1	30	18	53	1.61
BWAC453024P	513	641	1618	2157	1	30	24	60	1.80
BWAC453030P	567	711	2067	2753	1	30	30	66	2.01
BWAC453618P	636	793	1578	2096	1	36	18	66	2.01
BWAC453624P	706	884	1942	2586	1	36	24	71	2.16
BWAC453630P	778	970	2444	3254	1	36	30	76	2.30

**BWAC60 • Curved-Corner Worksurface for 60 Degree Angle**

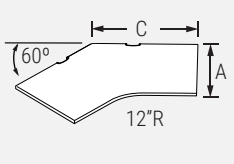

- Five-sided corner unit for 60 degree Corner Posts.
- Creates efficient use of space for computer or printer application.
- Please choose from DWT - Designer White, SIL - Silver or BLK - Black for scoop covers.

**NOTE: BWAC**

60°	24	18
	C	A
60° POST	WIDTH	DEPTH

PRODUCT CODE	PRICE LP*	GROUP HP*	T*	W*	SIZE/INCHES			WEIGHT VOL	
					H	W	D	LBS	FT <sup>3</sup>
BWAC602418P	303	378	504	905	1	24	18	33	0.99
BWAC602424P	318	395	628	1133	1	24	24	36	1.09
BWAC602430P	333	414	684	1227	1	24	30	39	1.19
BWAC603018P	411	516	1143	1520	1	30	18	48	1.46
BWAC603024P	447	561	1344	1793	1	30	24	52	1.58
BWAC603030P	481	601	1462	1947	1	30	30	56	1.71
BWAC603618P	588	734	1334	1767	1	36	18	66	2.01
BWAC603624P	632	789	1572	2096	1	36	24	71	2.16
BWAC603630P	678	843	1716	2285	1	36	30	76	2.31

**BWCE • Extended Curved-Corner Worksurface**

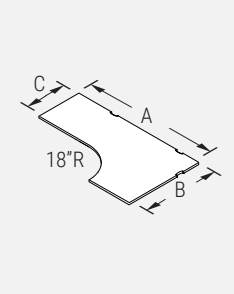

- Extended curved-corner unit with a radius user edge.
- Creates efficient use of a corner unit.
- Please choose from DWT - Designer White, SIL - Silver or BLK - Black for scoop covers.

**NOTE: BWCE**

60	42	24
A	B	C
WIDTH	WIDTH	LENGTH

PRODUCT CODE	PRICE LP*	GROUP HP*	T*	W*	SIZE/INCHES			WEIGHT VOL	
					H	W	D	LBS	FT <sup>3</sup>
BWCE426024P	628	788	1198	1970	1	60	42	57	2.2
BWCE426624P	693	867	1286	2056	1	66	42	62	2.5
BWCE427224P	767	1010	1414	2312	1	72	42	66	2.7
BWCE427824P	819	1025	1500	2486	1	78	42	71	2.9
BWCE428424P	883	1103	1626	2655	1	84	42	75	3.1
BWCE486024P	719	900	1500	2486	1	60	48	66	2.5
BWCE486624P	790	992	1587	2569	1	66	48	71	2.8
BWCE487224P	863	1079	1626	2655	1	72	48	76	3.1
BWCE487824P	937	1171	1755	2913	1	78	48	83	3.3
BWCE488424P	1008	1259	1885	3082	1	84	48	93	3.6
BWCE486030P	790	992	1626	2655	1	60	48	68	2.5
BWCE486630P	863	1079	1712	2784	1	66	48	74	2.8
BWCE487230P	937	1171	1755	2870	1	72	48	80	3.1
BWCE487830P	1008	1259	1885	3040	1	78	48	85	3.3
BWCE488430P	1062	1331	1970	3169	1	84	48	96	3.6
BWCE604224P	628	788	1198	1970	1	42	60	57	2.2
BWCE604824P	693	900	1500	2486	1	48	60	66	2.6
BWCE604830P	767	992	1626	2655	1	48	60	68	2.6
BWCE664224P	819	867	1286	2056	1	42	66	62	2.5
BWCE664824P	883	992	1587	2569	1	48	66	71	2.8
BWCE664830P	719	1079	1712	2784	1	48	66	74	2.8
BWCE724224P	790	1010	1414	2312	1	42	72	66	2.7
BWCE724824P	863	1079	1626	2655	1	48	72	76	3.1
BWCE724830P	937	1171	1755	2870	1	48	72	80	3.1
BWCE784224P	1008	1025	1500	2486	1	42	78	71	2.9
BWCE784824P	790	1171	1755	2913	1	48	78	83	3.3
BWCE784830P	863	1259	1885	3040	1	48	78	85	3.3
BWCE844224P	937	1103	1626	2655	1	42	84	75	3.1
BWCE844824P	1008	1259	1885	3082	1	48	84	93	3.6
BWCE844830P	1062	1331	1970	3169	1	48	84	96	3.6

LP = Thermally Fused Laminate, HP = High Pressure Laminate, T= High Pressure Laminate with Wood Trim, W= Wood Veneer

**BWCEC • Extended Curvilinear Corner Worksurface**

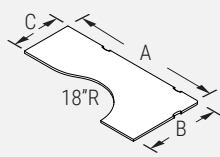

- Extended curved-corner unit with a radius user edge.
- Creates efficient use of a corner unit.
- Please choose from DWT - Designer White, SIL - Silver or BLK - Black for scoop covers.

NOTE: BWSC

66	42	24
A	B	C
WIDTH	WIDTH	LENGTH

PRODUCT CODE	PRICE LP*	GROUP HP*	T*	W*	SIZE/INCHES			WEIGHT VOL	
					A	B	C	LBS	FT <sup>3</sup>
BWCEC366024P	572	714	1024	1704	36	60	24	59	0.05
BWCEC366624P	600	750	1129	1873	36	66	24	65	0.60
BWCEC367224P	655	819	1227	2046	36	72	24	71	0.07
BWCEC367824P	709	889	1334	2217	36	78	24	77	0.07
BWCEC368424P	790	989	1432	2386	36	84	24	83	0.08
BWCEC426624P	691	862	1277	2046	42	66	24	76	0.07
BWCEC427224P	763	955	1405	2303	42	72	24	83	0.08
BWCEC427824P	816	1019	1491	2476	42	78	24	90	0.08
BWCEC428424P	876	1099	1620	2645	42	84	24	96	0.09
BWCEC487230P	932	1164	1747	2857	48	72	30	94	0.09
BWCEC487830P	1004	1256	1873	3028	48	78	30	102	0.09
BWCEC488424P	876	1099	1620	2645	48	84	24	110	0.10
BWCEC488430P	1057	1321	1963	3154	48	84	30	110	0.10
BWCEC603624P	572	714	1024	1704	60	36	24	59	0.05
BWCEC663624P	600	750	1129	1873	66	36	24	65	0.60
BWCEC664224P	691	862	1277	2046	66	42	24	76	0.07
BWCEC723624P	655	819	1227	2046	72	36	24	71	0.07
BWCEC724224P	763	955	1405	2303	72	42	24	83	0.08
BWCEC724830P	932	1164	1747	2857	72	48	30	94	0.09
BWCEC783624P	709	889	1334	2217	78	36	24	77	0.07
BWCEC784224P	816	1019	1491	2476	78	42	24	89	0.08
BWCEC784830P	1004	1256	1873	3028	78	48	30	102	0.09
BWCEC843624P	790	989	1432	2386	84	36	24	83	0.08
BWCEC844224P	790	989	1432	2386	84	42	24	96	0.09
BWCEC844824P	876	1099	1620	2645	84	48	24	110	0.10
BWCEC844830P	1057	1321	1963	3154	84	48	30	110	0.10

**BWSL • Curvilinear Arc Worksurface**

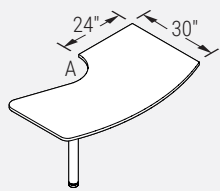

- Arc shaped worksurface provides an extended conferencing area.
- 1 BHML03 Monoleg included.
- Not recommended for use with modesty panel due to knee swing interference.
- For chrome finish on leg, please add \$107 list upcharge.

RIGHT HAND SHOWN  
MONOLEG MOUNTED ON  
THE RIGHT USER SIDE.

PRODUCT CODE	PRICE LP*	GROUP HP*	T*	W*	SIZE/INCHES			WEIGHT VOL	
					H	W	D	LBS	FT <sup>3</sup>
BWSL3060L	754	943	1099	1934	29	60	30	48	1.69
BWSL3066L	790	992	1223	2159	29	66	30	53	1.85
BWSL3072L	824	1035	1348	2427	29	72	30	58	2.01
BWSL3060R	754	943	1099	1934	29	60	30	48	1.69
BWSL3066R	790	992	1223	2159	29	66	30	53	1.85
BWSL3072R	824	1035	1348	2427	29	72	30	58	2.01

A = 27" for 60", 66" worksurfaces  
A = 26.5" for 72" worksurfaces

**BWSL • Curveliniar Arc Worksurface**

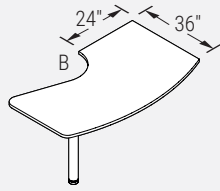

- Arc shaped worksurface provides an extended conferencing area.
- 1 BHML03 Monoleg included.
- For chrome finish on leg, please add \$107 list upcharge.

RIGHT HAND SHOWN  
MONOLEG MOUNTED ON  
THE RIGHT USER SIDE.

PRODUCT CODE	PRICE LP*	GROUP HP*	T*	W*	SIZE/INCHES			WEIGHT VOL	
					H	W	D	LBS	FT <sup>3</sup>
BWSL3660L	859	1079	1259	2203	29	60	36	57	2.07
BWSL3666L	916	1171	1403	2476	29	66	36	64	2.26
BWSL3672L	1003	1259	1549	2741	29	72	36	71	2.45
BWSL3660R	859	1079	1259	2203	29	60	36	57	2.07
BWSL3666R	916	1171	1403	2476	29	66	36	64	2.26
BWSL3672R	1003	1259	1549	2741	29	72	36	71	2.45

B = 33" for 60", 66" worksurfaces  
B = 32.5" for 72" worksurfaces

LP = Thermally Fused Laminate, HP = High Pressure Laminate, T= High Pressure Laminate with Wood Trim, W= Wood Veneer

**BWD • “D” Worksurface**

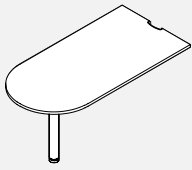

- Rounded worksurface for conferencing.
- Supported by Monoleg at one end and panel at the opposite end.
- 1 BHML03 Monoleg included.
- Modesty panel available, see BWMP (not included).
- For chrome finish on leg, please add \$107 list upcharge.

PRODUCT CODE	PRICE LP*	GROUP HP*	T*	W*	SIZE/INCHES			WEIGHT VOL	
					H	W	D	LBS	FT <sup>3</sup>
BWD2442P	492	619	815	925	1	42	24	27	0.97
BWD2448P	518	647	824	943	1	48	24	31	1.11
BWD2454P	534	664	856	1162	1	54	24	35	1.24
BWD2460P	544	680	876	1391	1	60	24	39	1.36
BWD2466P	557	702	902	1439	1	66	24	43	1.52
BWD2472P	583	728	941	1577	1	72	24	47	1.66
BWD3048P	518	652	858	1500	1	48	30	38	1.38
BWD3054P	546	685	900	1522	1	54	30	43	1.56
BWD3060P	584	729	941	1545	1	60	30	48	1.69
BWD3066P	612	765	986	1630	1	66	30	53	1.82
BWD3072P	646	806	1052	1720	1	72	30	58	2.01
BWD3078P	682	858	1092	2056	1	78	30	63	2.25
BWD3084P	745	935	1198	2229	1	84	30	68	2.42

**BWP • “P” Worksurface**

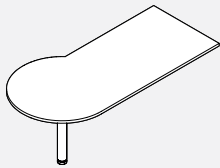

LEFT HAND SHOWN

- Rounded worksurface provides an extended conferencing area.
- 36" diameter end.
- Supported by monoleg at one end and panel at the opposite end.
- 1 BHML03 Monoleg included.
- Modesty panel available, see BWMP (not included).
- For chrome finish on leg, please add \$107 list upcharge.

PRODUCT CODE	PRICE LP*	GROUP HP*	T*	W*	SIZE/INCHES			WEIGHT VOL	
					H	W	D	LBS	FT <sup>3</sup>
BWPL3054	741	924	1155	1836	1	54	36	51	1.87
BWPL3060	775	968	1196	2132	1	60	36	58	2.03
BWPL3066	840	1054	1297	2427	1	66	36	65	2.24
BWPL3072	875	1102	1365	2727	1	72	36	70	2.41
BWPL3084	1133	1223	1515	3251	1	84	36	81	2.79
BWPR3054	741	924	1155	1836	1	54	36	51	1.87
BWPR3060	775	968	1196	2132	1	60	36	58	2.03
BWPR3066	840	1054	1297	2427	1	66	36	65	2.24
BWPR3072	875	1102	1365	2727	1	72	36	70	2.41
BWPR3084	973	1223	1515	3251	1	84	36	81	2.79

**BWMP • “D” and “P” Worksurface Modesty Panel**

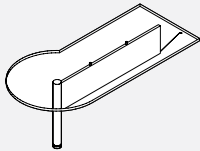

- Made of cold rolled steel, fastens to the worksurface and Monoleg for additional privacy.

PRODUCT CODE	PRICE	SIZE/INCHES			WEIGHT VOL	
		H	W	D	LBS	FT <sup>3</sup>
BWMP1248	120	1	32	12	12	0.4
BWMP1254	145	1	38	12	15	0.47
BWMP1260	168	1	44	12	17	0.53
BWMP1266	195	1	50	12	20	0.61
BWMP1272	217	1	56	12	22	0.66
BWMP1278	234	1	62	12	25	0.71
BWMP1284	250	1	68	12	27	0.79

**BWR • Radius Worksurface**

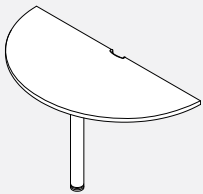

- Rounded worksurface for conferencing provides a radius corner.
- 18" and 24" come with 1 BHML03 Monoleg and 30" comes with 2.
- Radius cut out on the straight edge allows space for aluminum trims.
- For chrome finish on leg, please add \$107 list upcharge for each leg.

PRODUCT CODE	PRICE LP*	GROUP HP*	T*	W*	SIZE/INCHES			WEIGHT VOL	
					H	W	D	LBS	FT <sup>3</sup>
BWR18P	431	540	670	1033	1	38.5	18	27	1.70
BWR24P	498	625	794	1258	1	50.5	24	41	2.20
BWR30P	903	1129	1339	1836	1	62.5	30	59	2.70

**BWRTD • Teardrop Worksurface**

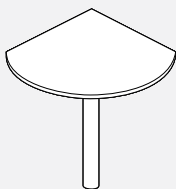

- Rounded worksurface for conferencing provides a radius corner from a worksurface to worksurface.
- 1 BHML03 Monoleg included.
- For chrome finish on leg, please add \$107 list upcharge.

PRODUCT CODE	PRICE LP*	GROUP HP*	T*	W*	SIZE/INCHES			WEIGHT VOL	
					H	W	D	LBS	FT <sup>3</sup>
BWRTD18	260	284	355	446	1	18	18	24	1.60
BWRTD24	328	367	496	660	1	24	24	33	1.90
BWRTD30	417	479	685	945	1	30	30	43	2.20

LP = Thermally Fused Laminate, HP = High Pressure Laminate, T= High Pressure Laminate with Wood Trim, W= Wood Veneer

**BWRP • Corner Radius Worksurface With Cutout**

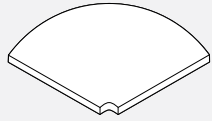

- Corner Radius Worksurface with Cut-Out allows worksurface to be used around a post.
- Cut out fits snug to the post, if trim is attached to the post, the worksurface or PVC trim may need to be cut on site to fit.

PRODUCT CODE	PRICE LP*	GROUP			SIZE/INCHES			WEIGHT VOL	
		HP*	T*	W*	H	W	D	LBS	FT <sup>3</sup>
BWRP1818	153	188	475	639	1	21	21	12	0.40
BWRP2424	218	275	489	665	1	27	27	19	0.64
BWRP3030	270	339	608	840	1	33	33	29	1.00

**BWT • Transaction Worksurface**

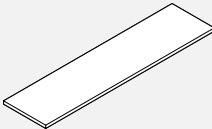

- Attaches to the top of a 37" or 42" high panel to form a transaction worksurface.
- To attach a Boulevard 1 37" high panel please specify BHBT37, all other heights specify BHBT02.
- To attach a Boulevard 1 panel with flat trim, please specify BHBT37FT or BHBT02FT.

PRODUCT CODE	PRICE LP*	GROUP			SIZE/INCHES			WEIGHT VOL	
		HP*	T*	W*	H	W	D	LBS	FT <sup>3</sup>
BWT1512	64	72	141	214	1	12	15	5	0.22
BWT1518	75	95	179	242	1	18	15	7	0.30
BWT1524	95	115	215	323	1	24	15	10	0.38
BWT1530	112	136	252	382	1	30	15	12	0.46
BWT1536	126	158	287	419	1	36	15	14	0.54
BWT1542	146	179	328	480	1	42	15	17	0.62
BWT1548	161	203	365	522	1	48	15	19	0.70
BWT1554	178	221	401	545	1	54	15	22	0.78
BWT1560	198	247	436	571	1	60	15	24	0.86
BWT1566	212	266	475	626	1	66	15	28	0.94
BWT1572	230	287	511	786	1	72	15	29	1.02
BWT1578	249	311	550	870	1	78	15	31	1.10
BWT1584	266	331	594	965	1	84	15	34	1.18

**BWTC • Transaction Corner Worksurface**

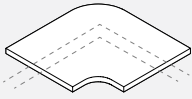

- Attaches to the top of a 37" or 42" high panel to form a corner transaction worksurface.
- Covers 12" of a panel.
- To attach a 37" high panel please specify BHBT37, all other heights specify BHBT02.
- To attach a Boulevard 1 panel with flat trim, please specify BHBT37FT or BHBT02FT.

PRODUCT CODE	PRICE LP*	GROUP			SIZE/INCHES			WEIGHT VOL	
		HP*	T*	W*	H	W	D	LBS	FT <sup>3</sup>
BWTC90	144	176	285	637	1	20.7	20.7	11	0.49
BWTC45	173	215	334	660	1	21.5	21.5	12	0.53
BWTC60	172	215	334	660	1	22.5	22.5	14	0.60

**BWTT • Transaction "T" Worksurface**

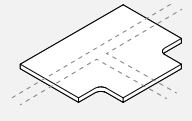

- Attaches to the top of a 37" or 42" high panel to form a "T" corner transaction worksurface
- Covers 12" of a panel.
- To attach a 37" high panel please specify BHBT37, all other heights specify BHBT02.

PRODUCT CODE	PRICE LP*	GROUP			SIZE/INCHES			WEIGHT VOL	
		HP*	T*	W*	H	W	D	LBS	FT <sup>3</sup>
BWTT2721	151	188	312	660	1	21.5	26.5	15	0.6

**BWTAC • Transaction Worksurface for 45 Degree Corner Worksurface**

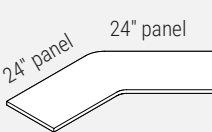

- Attaches to the top of 37" or 42" high panel to form a 45 degree corner transaction worksurface.
- To attach a 37" high panel please specify BHBT37, all other heights specify BHBT02.

PRODUCT CODE	PRICE LP*	GROUP			SIZE/INCHES			WEIGHT VOL	
		HP*	T*	W*	H	W	D	LBS	FT <sup>3</sup>
BWTAC452415	628	788	822	1155	1	47	15	39	1.38

**BWTAC • Transaction Worksurface for 60 Degree Corner Worksurface**



- Attaches to the top of 42" high panel to form a 60 degree corner transaction worksurface.
- To attach a 37" high panel please specify BHBT37, all other heights specify BHBT02.

PRODUCT CODE	PRICE LP*	GROUP			SIZE/INCHES			WEIGHT VOL	
		HP*	T*	W*	H	W	D	LBS	FT <sup>3</sup>
BWTAC602415	680	854	900	1188	1	44	15	38	1.32

LP = Thermally Fused Laminate, HP = High Pressure Laminate, T= High Pressure Laminate with Wood Trim, W= Wood Veneer

**BWTD • Transaction “D” Worksurface**

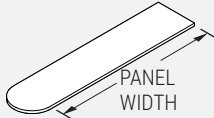

- Attaches to the top of a 37" or 42" high panel to form a transaction worksurface with a radiused end.
- Surface overhangs the panel by 7 1/2" on one side.
- To attach a 37" high panel please specify BHBT37, all other heights specify BHBT02.

PRODUCT CODE	PRICE LP*	GROUP			SIZE/INCHES			WEIGHT VOL	
		HP*	T*	W*	H	W	D	LBS	FT <sup>3</sup>
BWTD1530	144	176	328	534	1	37.5	15	17	0.65
BWTD1536	155	190	345	566	1	43.5	15	19	0.69
BWTD1542	172	212	378	608	1	49.5	15	22	0.74
BWTD1548	188	236	414	665	1	55.5	15	25	0.77
BWTD1554	204	254	448	691	1	61.5	15	27	0.85
BWTD1560	226	281	492	714	1	67.5	15	30	0.94
BWTD1566	242	302	529	817	1	73.5	15	33	1.02
BWTD1572	266	328	567	913	1	79.5	15	35	1.10

**BWTD • Transaction Double “D” Worksurface**

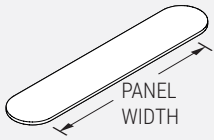

- Attaches to the top of a 37" or 42" high panel to form a transaction worksurface with 2 radius ends.
- Surface overhangs the panel by 7 1/2" on each end.
- To attach a 37" high panel please specify BHBT37, all other heights specify BHBT02.

PRODUCT CODE	PRICE LP*	GROUP			SIZE/INCHES			WEIGHT VOL	
		HP*	T*	W*	H	W	D	LBS	FT <sup>3</sup>
BWTD1548	211	266	490	817	1	63	15	28	1.00
BWTD1554	228	287	536	860	1	69	15	31	1.01
BWTD1560	248	311	565	884	1	75	15	33	1.04
BWTD1566	266	334	604	1013	1	81	15	35	1.13
BWTD1572	287	361	642	1135	1	87	15	38	1.21

**BWTE • Elliptical Transaction Worksurface**

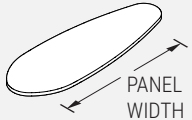

- Attaches to the top of a 37" or 42" high panel to form a transaction worksurface.
- To attach a 37" high panel please specify BHBT37, all other heights specify BHBT02.
- Depth different than standard tops.

PRODUCT CODE	PRICE LP*	GROUP			SIZE/INCHES			WEIGHT VOL	
		HP*	T*	W*	H	W	D	LBS	FT <sup>3</sup>
BWTE36	302	378	971	1398	1	52	18	22	0.78
BWTE42	345	433	1079	1512	1	58	19	24	0.81

**BWTP • Oval Transaction Worksurface**

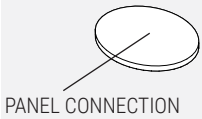

- Attaches to the top of a 37" or 42" high panel to form a transaction worksurface.
- To attach a 37" high panel please specify BHBT37, all other heights specify BHBT02.
- Must be specified at post condition or panel joint.

PRODUCT CODE	PRICE LP*	GROUP			SIZE/INCHES			WEIGHT VOL	
		HP*	T*	W*	H	W	D	LBS	FT <sup>3</sup>
BWTP1518	216	271	439	693	1	15	18	10	0.35

**BWCD • Round Table**



- Freestanding round meeting table with 4-prong tubular base.

PRODUCT CODE	PRICE LP*	GROUP			SIZE/INCHES			WEIGHT VOL	
		HP*	T*	W*	H	W	D	LBS	FT <sup>3</sup>
BWCD30	448	495	829	1078	29	30 dia	30 dia	35	10.0
BWCD36	463	572	992	1235	29	36 dia	36 dia	42	10.0
BWCD42	574	718	1223	1661	29	42 dia	42 dia	52	11.0

**BWSQ • Square Table**

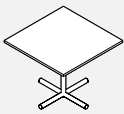

- Freestanding square meeting table with 4-prong tubular base.

PRODUCT CODE	PRICE LP*	GROUP			SIZE/INCHES			WEIGHT VOL	
		HP*	T*	W*	H	W	D	LBS	FT <sup>3</sup>
BWSQ24	450	473	702	986	29	24	24	34	10.0
BWSQ30	448	495	829	1078	29	30	30	38	10.0
BWSQ36	459	572	1005	1235	29	36	36	46	11.0
BWSQ42	659	718	1223	1661	29	42	42	57	11.0

LP = Thermally Fused Laminate, HP = High Pressure Laminate, T= High Pressure Laminate with Wood Trim, W= Wood Veneer



**BHCL • "C" Leg**

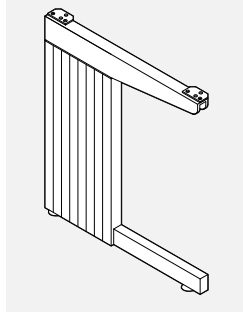

- Attaches to panel support worksurface or to provide freestanding table support.
- Steel structure, PVC cover.
- Universal non-handed.
- For a single rectangular freestanding worksurface application, specify two "C" legs and one modesty panel of corresponding width.
- May be used as a shared leg between two adjoining worksurfaces. Specify one "C" leg, one modesty panel of corresponding width, plus one modesty panel extension bracket.
- For corner worksurfaces, specify two "C" legs, one corner leg and two modesty panels 6" shorter than rear sides of the corner worksurface.
- Can be used as a floor support in a panel-attached application (similar to a cantilever).
- Includes worksurface mounting brackets with screws, bracket retainer clip and panel bracket.
- Accommodates 15" knee space.

PRODUCT CODE	PRICE	SIZE/INCHES			WEIGHT VOL	
		H	W	D	LBS	FT <sup>3</sup>
BHCL2618	211	25	1	18	7	0.27
BHCL2624	218	25	1	24	8	0.36
BHCL2918	227	28	1	18	8	0.30
BHCL2924	238	28	1	24	9	0.40

**BKC • Corner Leg**

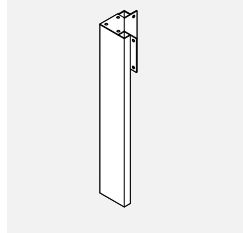

- Five-sided worksurface support.
- Steel construction.
- Non handed.
- Includes bolts for modesty panel attachment.
- For corner worksurfaces, specify two "C" legs, one corner leg and two modesty panels 6" shorter than rear sides of the corner worksurface.

PRODUCT CODE	PRICE	SIZE/INCHES			WEIGHT VOL	
		H	W	D	LBS	FT <sup>3</sup>
BKC26	126	25	7	7	3.0	0.02
BKC29	145	28	7	7	3.2	0.02

**BKMP • Modesty Panel**

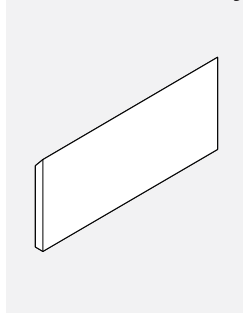

- For rectangular worksurfaces, specify modesty panel of corresponding width. For corner worksurfaces, specify two modesty panels 6" shorter than rear side of corner worksurface.
- Attaches between two "C" legs, or between one "C" leg and a corner leg, or a shared "C" leg and "C" leg at the end of a run.
- Includes brackets and screws to attach modesty panel to worksurface.

PRODUCT CODE	PRICE	SIZE/INCHES			WEIGHT VOL	
		H	W	D	LBS	FT <sup>3</sup>
BKMP1224	145	11	24	0.25	2.75	0.17
BKMP1230	153	11	30	0.25	2.75	0.21
BKMP1236	163	11	36	0.25	3.00	0.25
BKMP1242	172	11	42	0.25	4.00	0.29
BKMP1248	179	11	48	0.25	4.50	0.33
BKMP1254	188	11	54	0.25	5.00	0.38
BKMP1260	199	11	60	0.25	5.50	0.42

**BHMEB • Modesty Panel Extension Bracket**

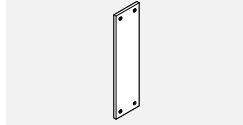

- Modesty panel extension bracket made of cold rolled steel.
- Attaches the modesty panel of an adjoining worksurface to a shared "C" leg.
- Includes all attachment hardware.

PRODUCT CODE	PRICE	SIZE/INCHES			WEIGHT VOL	
		H	W	D	LBS	FT <sup>3</sup>
BHMEB01	23	10	1.5	0.125	0.5	0.01

**BHFG • Full Gable - Self Edged**

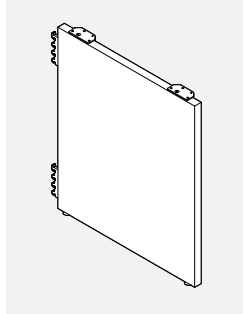

- Provides floor standing support while enclosing an end of a run of worksurfaces.
- Includes attachment hardware, bracket retainer clip and leveling glides.
- Non-handed.
- May be used as a shared gable between two adjoining worksurfaces.

PRODUCT CODE	PRICE LP*	GROUP HP*	SIZE/INCHES			WEIGHT VOL	
			H	W	D	LBS	FT <sup>3</sup>
BHFG2608	130	163	25	1	8	7	0.14
BHFG2612	166	209	25	1	12	13	0.21
BHFG2618	203	253	25	1	18	13	0.27
BHFG2624	222	280	25	1	24	19	0.36
BHFG2630	301	374	25	1	30	23	0.45
BHFG2636	378	473	25	1	36	24	0.57
BHFG2908	130	163	28	1	8	7	0.16
BHFG2912	166	209	28	1	12	14	0.30
BHFG2918	203	253	28	1	18	14	0.30
BHFG2924	222	280	28	1	24	17	0.40
BHFG2930	301	374	28	1	30	21	0.50
BHFG2936	378	473	28	1	36	26	0.65

LP = Thermally Fused Laminate, HP = High Pressure Laminate, T= High Pressure Laminate with Wood Trim, W= Wood Veneer

**BHFGP • Full Gable - 3 mm PVC Edged**

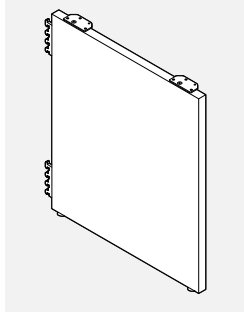

- Provides floor standing support while enclosing an end of a run of worksurfaces.
- Includes attachment hardware, bracket retainer clip and leveling glides.
- Provides consistent edging matching the worksurface trim.
- Handed once installed.
- May be used as a shared gable between two adjoining worksurfaces.

PRODUCT CODE	PRICE LP*	GROUP HP*	SIZE/INCHES			WEIGHT VOL	
			H	W	D	LBS	FT <sup>3</sup>
BHFGP2608	130	163	25	1	8	7	0.14
BHFGP2612	166	209	25	1	12	13	0.21
BHFGP2618	203	253	25	1	18	13	0.27
BHFGP2624	222	280	25	1	24	19	0.36
BHFGP2630	301	374	25	1	30	23	0.45
BHFGP2636	378	473	25	1	36	24	0.57
BHFGP2908	130	163	28	1	8	7	0.16
BHFGP2912	166	209	28	1	12	14	0.30
BHFGP2918	203	253	28	1	18	14	0.30
BHFGP2924	222	280	28	1	24	17	0.40
BHFGP2930	301	374	28	1	30	21	0.50
BHFGP2936	378	473	28	1	36	26	0.65

**BHPG • "P" Shaped Full Gable - 3 mm PVC Edged**

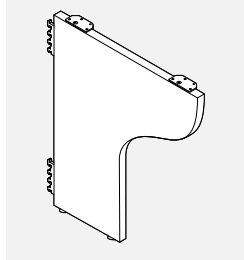

- Provides floor standing support while enclosing an end of a run of worksurfaces.
- Includes attachment hardware, bracket retainer clip and leveling glides.
- Handed due to hardware attachment and PVC edge.

PRODUCT CODE	PRICE LP*	GROUP HP*	SIZE/INCHES			WEIGHT VOL	
			H	W	D	LBS	FT <sup>3</sup>
BHPG2624L	222	280	25	1	24	19	0.36
BHPG2924L	222	280	28	1	24	17	0.40
BHPG2624R	222	280	25	1	24	19	0.36
BHPG2924R	222	280	28	1	24	17	0.40

**BHLEG • Gable Leg**

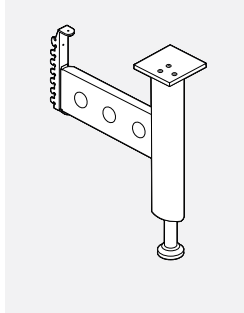

- Supports the worksurface and enhances the stability of connected panels.
- Universal leg plate bolts to the underside of the worksurface.
- Can be configured on-site for left, right or shared worksurface support application on front edge.
- Back edge does not have shared support.
- Tubular leg section adjusts in 1" increments, the leveler can be used for fine adjustment.
- 1" increment leg adjustment and 1" increment panel slots allow the leg of installed worksurface to be supported from 26" to 32". (Leg must be removed from panel to manually adjust.)
- Side plate is secured to the slots in the vertical of the Boulevard 1 or System 3 panels and the leg plate bolts to underside of the worksurface.
- Made of extruded aluminum and steel.
- Includes all mounting hardware to connect to panel and worksurface.

PRODUCT CODE	PRICE	GROUP	SIZE/INCHES			WEIGHT VOL	
			H	W	D	LBS	FT <sup>3</sup>
BHLEG	188		28	6	23	8	0.15

**BRTHLEG • Boulevard Leg Assembly**

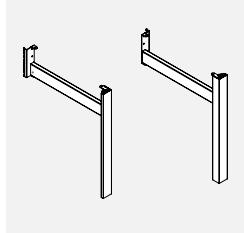

- Boulevard leg assembly attaches to a Boulevard panel for applications which require functionality of Boulevard panels with an open environment.
- One leg with horizontal member connecting to 1" increment slots in panel's vertical frame member. Provides support to panel and panel-connected worksurface at the end of a run; design coordinated with Boulevard freestanding tables.
- Supports 24" and 30" deep worksurfaces. By adding 2 BHBF01 flat brackets and 1 BHBC02 corner bracket, a single leg can then support the adjoining worksurface. Leveling glide is standard. No worksurface-supporting beams, use panel cantilevers and storage for worksurface support. One aluminum leg with steel structure – specify left or right and 24" or 30" deep for corresponding worksurface depths. Panel bracket, dislodgment clip and worksurface hardware included.
- Please specify paint finish for support.

PRODUCT CODE	PRICE	GROUP	SIZE/INCHES			WEIGHT VOL	
			H	W	D	LBS	FT <sup>3</sup>
BRTHLEG24LL	405		28	2.5	24	9	1.25
BRTHLEG24RL	405		28	2.5	24	9	1.25
BRTHLEG30LL	425		28	2.5	30	11	1.45
BRTHLEG30RL	425		28	2.5	30	11	1.45

**BRTBL • Boulevard Leg Assembly**

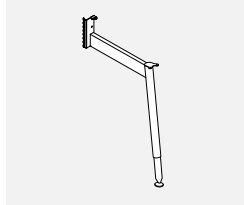

- Boulevard leg assembly attaches to a Boulevard panel for applications which require functionality of Boulevard panels with an open environment.
- Panel bracket secures the leg to the panel in 1" increments, within a 24" to 32" height range.
- Panel mounting bracket is reversible for non-handed applications.
- Supports 24" and 30" deep worksurfaces. By adding 2 BHBF01 flat brackets and 1 BHBC02 corner bracket, a single leg can then support the adjoining worksurface. Leveling glide is standard. No worksurface-supporting beams, use panel cantilevers and storage for worksurface support. Panel bracket, dislodgment clip and worksurface hardware included.
- Leveling glide is standard.

PRODUCT CODE	PRICE	GROUP	SIZE/INCHES			WEIGHT VOL	
			H	W	D	LBS	FT <sup>3</sup>
BRTBL	417		28	3	24	12	1.25

LP = Thermally Fused Laminate, HP = High Pressure Laminate, T= High Pressure Laminate with Wood Trim, W= Wood Veneer

**BHML • Mono Leg**

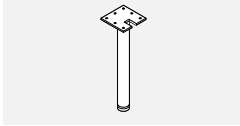

- 3" diameter mono leg provides support for worksurfaces.
- Top plate welded to leg.
- 8" x 8" plated attached to worksurface with #10 3/4" wood screws, included.
- 1" height adjustment range.
- For chrome finish on leg, please add \$107 list upcharge.

PRODUCT CODE	PRICE	SIZE / INCHES			WEIGHT VOL	
		H	W	D	LBS	FT <sup>3</sup>
BHML03	190	28	3	3	8	0.15

**LATBL • Tapered Leg**

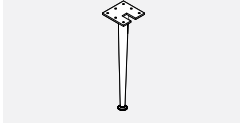

- Tapered leg provides support for worksurfaces.
- Top plate welded to leg.
- 8" x 8" plated attached to worksurface with #10 3/4" wood screws, included.
- 1" height-adjustment range.
- For chrome finish on leg, please add \$107 list upcharge.

PRODUCT CODE	PRICE	SIZE / INCHES			WEIGHT VOL	
		H	W	D	LBS	FT <sup>3</sup>
LATBL28	227	28	3	3	8	0.15

**BHC • Cantilever**

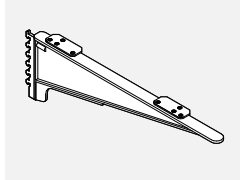

- Universal cantilever with steel attachment bracket constructed of cast aluminum to provide support for worksurfaces.
- Attaches a worksurface to a panel.
- May be used for shared worksurface support.
- Interchangeable in the field for left or right positioning.
- Includes bracket retainer clip.

PRODUCT CODE	PRICE	SIZE / INCHES			WEIGHT VOL	
		H	W	D	LBS	FT <sup>3</sup>
BHC18	77	7	17	2.5	17	0.04
BHC24	77	7	23	2.5	23	0.05

LP = Thermally Fused Laminate, HP = High Pressure Laminate, T= High Pressure Laminate with Wood Trim, W= Wood Veneer

**BHBC • Corner End Bracket**

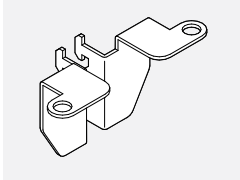

- Formed steel bracket for a corner worksurface or a straight worksurface.
- Attaches a corner of any worksurface to a panel through the panel vertical slots.
- Priced one left and one right per package.
- Includes bracket retainer clip.

PRODUCT CODE	PRICE	SIZE/INCHES			WEIGHT VOL	
		H	W	D	LBS	FT <sup>3</sup>
BHBC02	26	3.3	1.5	2.3	2	0.007

**BHBF • Flat Bracket**

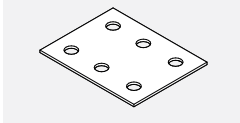

- Flat Bracket made of cold rolled steel.
- May be used to ensure alignment of neighboring worksurfaces.

PRODUCT CODE	PRICE	SIZE/INCHES			WEIGHT VOL	
		H	W	D	LBS	FT <sup>3</sup>
BHBF01	18	0.1	3	4	0.5	0.007

**BHBT • Transaction Bracket**

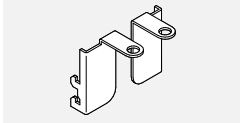

- For use on 34", 42", 50", 58", 66", 74" and 82" high Boulevard panels.
- Transaction bracket made of cold rolled steel.
- To provide a secure attachment of a transaction worksurface.
- Priced one left and one right per package.
- Includes bracket retainer clip.

PRODUCT CODE	PRICE	SIZE/INCHES			WEIGHT VOL	
		H	W	D	LBS	FT <sup>3</sup>
BHBT02	26	3.3	1.5	2.3	2	0.001

**BHBT • Transaction Bracket for 37"-High Boulevard 1 Panel**

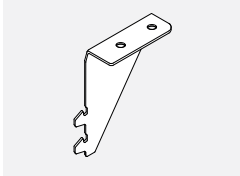

- Transaction Bracket made of cold rolled steel.
- To provide a secure attachment of a transaction worksurface for a 37" high Boulevard 1 panel only. Transaction Bracket engages with the top slots in the 37" high panel to supported for the transaction worksurface.
- Priced one left and one right per package.
- Includes bracket retainer clip.

PRODUCT CODE	PRICE	SIZE/INCHES			WEIGHT VOL	
		H	W	D	LBS	FT <sup>3</sup>
BHBT37	32	4	1	3	0.5	0.007

**BHBZ • "Z" Bracket**

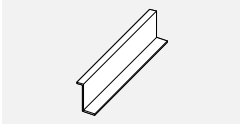

- Attaches two different heights of worksurfaces.
- To be used in conjunction with a cantilever.

PRODUCT CODE	PRICE	SIZE/INCHES			WEIGHT VOL	
		H	W	D	LBS	FT <sup>3</sup>
BHBZ03	75	4	21	4	2	0.190

**FTATB • Boulevard Connector Kit**

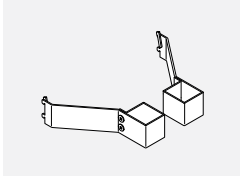

- FreeFit to Boulevard kit secures FreeFit height-adjustable freestanding tables to parallel Boulevard panels.
- It provides panel/table alignment, preventing moving parts from rubbing against panel vertical surfaces and maintains 1" clearance around table surface perimeter.
- Standard metal finishes.
- All hardware included.
- Sold as a pair.

PRODUCT CODE	PRICE	SIZE/INCHES			WEIGHT VOL	
		H	W	D	LBS	FT <sup>3</sup>
FTATB	191	10	6.5	10	7.00	0.50

**LHC • HAT Channel**

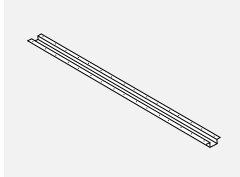

PRODUCT CODE	PRICE	SIZE/INCHES			WEIGHT LBS	VOL FT <sup>3</sup>
		H	W	D		
LHC40	75	1.4	40	5	4	0.20
LHC46	83	1.4	46	5	6	0.22
LHC52	91	1.4	52	5	7	0.25
LHC58	102	1.4	58	5	8	0.28
LHC64	113	1.4	64	5	9	0.31
LHC70	124	1.4	70	5	10	0.33

LP = Thermally Fused Laminate, HP = High Pressure Laminate, T= High Pressure Laminate with Wood Trim, W= Wood Veneer

**TECHNICAL INFORMATION FOR 9300 SERIES PEDESTALS****General Information**

9300 Series Pedestals feature center pull handles (models ending in "C") and full pull handles (models ending in "P"). Freestanding, mobile, and worksurface supporting options available. Quality steel construction. File drawers hold letter or A4 front-to-back and legal side-to-side configurations. Products are finished in a highly durable dry epoxy powder coating and drawer body interiors are finished with 100% recycled paint. Counterweights are included in freestanding and mobile pedestals to meet applicable ANSI/BIFMA X5.9.

**Features**

- Cold rolled steel construction consisting of 16 ga front and back base with 22 ga case.
- Reinforced welded construction.
- Inset drawer fronts and flush base.
- Double-wall construction on all drawer fronts.
- Full extension ball bearing slides on file drawers and  $\frac{3}{4}$  extension on box drawers.
- Rubber bumpers on slides for quietness.
- Worksurface supporting option available (includes mounting holes at top of unit).
- 1 pencil tray and 1 drawer divider are included with each unit containing a box drawer.
- Each file drawer includes a hanging file bar.
- Levelers provide 1" height adjustment.
- Counterweights included for freestanding and mobile pedestals.
- Includes lock with 2 keys.
- Lock is located at the top right of the case above the top drawer.
- Keyed alike option available and can be keyed alike to other storage components.

**Sizes**

- 15" width
  - 19", 23", and 29" depths
- Interior drawer depths:
- 19" Deep pedestals
    - 17 1/4" deep box drawers
    - 16 1/16" deep file drawers
  - 23" deep pedestals
    - 20 3/16" deep box drawers
    - 19 7/16" deep file drawers
  - 29" deep pedestals
    - 26 5/16" deep box drawers
    - 26 1/16" deep file drawers

**Drawer Heights**

Box drawer fronts are 6"H with 5" interior height.  
File drawer fronts are 12"H with 10 9/16" interior height.

**TECHNICAL INFORMATION FOR 9300 SERIES PEDESTALS****General Information**

Prime premium filing and storage products pre-configured to suit your needs; featuring fixed front or receding doors with center pull handles and fully welded seamless tops to deliver strength and clean aesthetics. Premium quality steel construction. File drawers accommodate legal, letter or A4 sizes in back-to-front and side-to-side configurations. Products are finished in a highly durable dry epoxy powder coating and drawer body interiors are finished with 100% recycled paint.

Counterweights are recommended for use in all laterals, pedestals and freestanding files of all widths and heights to meet applicable ANSI/BIFMA X5.9. (Counterweights are offered as an option on all products where required to meet applicable ANSI/BIFMA standard.)

**Features**

- Premium steel construction, 18-22 gauge steel components.
- Full welded and reinforced case construction.
- Interlock system allows only one drawer to open at a time for safety.
- Most products feature full overlay fronts, with some exceptions such as units with receding doors where the front is inset in the case.
- Double wall construction on all drawer and door fronts.
- Full extension roller bearing glides on all drawers.
- Anti-bounce-back safety feature prevents drawers from sliding open.
- Receding doors slide into the cabinet and allow the shelf to be pulled out.
- All pedestals are equipped with four leveling glides, providing 1.5" of height adjustment.
- All other units equipped with four leveling glides providing 1" height adjustment and can be accessed from the interior of the cabinets for ease of adjustment.
- On units with drawers and hinged doors, locks are located at the center of the case above the top opening.
- Lock position on towers with wardrobes is below the handle when center pull is selected.
- Each lock includes 2 keys; locks are standard with removable cores.
- Key assignment is random or can be specified for specific key number for key alike applications.

**Overhead Storage**

- Overhead cabinets: 7 widths in 6" increments.
- 14 5/8" high cases with interior clear height of 12".
- 13" deep units have interior clear dimension of 12.7".
- 16" deep units have interior clear dimension of 15.7".
- Open shelves: 7 widths in 6" increments.
- Shelves are 12 1/2" deep with 7 1/2" high side gables

**Pedestals**

- Freestanding- and worksurface-supporting options available.
- Worksurface-supporting includes mounting holes at top of unit.
- 1 pencil tray and 1 drawer divider are included with each unit containing a box drawer.
- File drawers hold legal, letter or A4 sizes in back-to-front and side-to-side configurations.
- Each file drawer includes a hanging file bar and conversion rails.
- Freestanding units BSPF can be specified with optional non-locking casters to convert to a mobile unit.
- 15" width x 18", 22", and 28" depths.

Interior drawer depth is as follows:

- 15" deep drawers for 18" deep pedestals.
- 19" deep drawers for 22" deep pedestals.
- 25" deep drawers for 28" deep pedestals.

File drawer capacity:

- 14 3/8" filing capacity for file drawers in 18" pedestals.
- 18 3/8" filing capacity for file drawers in 22" pedestals.
- 24 3/8" filing capacity for file drawers in 28" pedestals.

**Laterals**

- 18" depth with interior depth of 16".
- 30", 36", and 42" widths.
- Available in 2 to 6 drawer high (28"H – 77.6"H).

File drawer capacity:

- 30" wide units
  - 26 5/8" in letter and legal side-to-side.
  - 30 1/2" in letter front-to-back .
  - 15 1/4" with 10" side space in legal front-to-back.
- 36" wide units
  - 32 5/8" in letter and legal side-to-side.
  - 30 1/2" with 6 1/2" side space in letter front-to-back.
  - 30 1/2" in legal front-to-back.
- 42" wide units
  - 58 5/8" in letter and legal side-to-side.
  - 45 3/4" in letter front-to-back.
  - 30 1/2" with 6 1/2" side space in legal front-to-back.

## TECHNICAL INFORMATION FOR PRIME SERIES

### Storage Cabinets

- 18" depth.
- 30", 36", and 42" widths.
- Available in 2- to 5-high configurations (28"H – 65.6"H).

### Towers

- Include coat rod and shelf to accommodate personal items.
- The top of the storage compartment is perforated for ventilation.
- Includes locks with 2 keys each.
  - Closed storage comes with 3 locks – one for the drawers, one for the cupboard, and one for the wardrobe.
  - Side open storage comes with 2 locks – one of the drawers and one for the wardrobe.
- 24" depth.
- 24" width.
- 50", 54", and 66" nominal heights available to coordinate with Teknion's panel systems.

## STORAGE COMPONENTS - GUIDELINES FOR ORDERING PRODUCT

### Codes

The price list uses a numbering system with meaningful alphanumeric characters to create a simple-to-understand product number. This makes specifying the product much easier and more accurate.

### How to Specify

- Specify storage pedestal type and size by code, including depth.
- Specify metal color (eg. BLK for Black).
- Specify key random, key list provided, or key number (eg. 401).
- Specify worksurface supporting (1 = Yes, 2 = No).
- Specify counterweight if pedestal is not worksurface supporting (NN = No Counterweight).

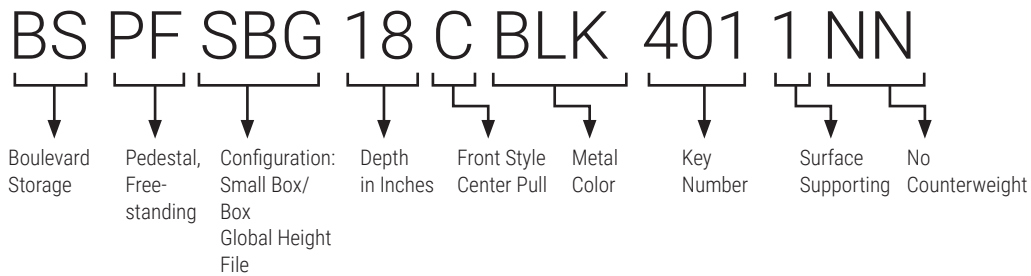

**BSKSS • Panel-Mounted Shelf**

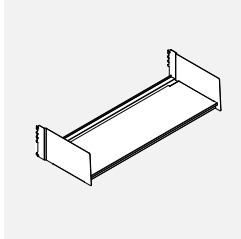

- 14" deep panel-mounted storage shelf with backlip.
- Mounting brackets are included.

PRODUCT CODE	PRICE	SIZE/INCHES			WEIGHT LBS	VOL FT <sup>3</sup>
		H	W	D		
BSKSS24	115	7.45	23.44	14.73	12.8	1.5
BSKSS30	122	7.45	29.44	14.73	14.8	1.9
BSKSS36	134	7.45	35.44	14.73	16.8	2.3
BSKSS42	136	7.45	41.44	14.73	18.8	2.6
BSKSS48	146	7.45	47.44	14.73	20.8	3.0
BSKSS54	155	7.45	53.44	14.73	22.8	3.4
BSKSS60	158	7.45	59.44	14.73	24.8	3.8

**BLSLF • Flush Front Overhead Cabinet**

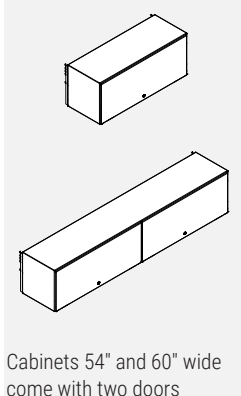

- Flush front overhead cabinet is panel mounted lockable storage unit.
- The door retracts inside/within the overhead cabinet.
- Locks can be keyed alike to match other lockable storage components or keyed random to provide a dedicated lock.
- Available in 13" and 16" depths, 24" to 60" widths at 6" increments.
- Cabinets 54" and 60" wide come with two doors.
- Includes mounting hardware as specified, lock and keys.
- Lock secures into bottom shelf.
- Can be mounted at any height, however 66" high panels are recommended.
- Shipped assembled.

Cabinets 54" and 60" wide come with two doors

PRODUCT CODE	PRICE	SIZE/INCHES			WEIGHT LBS	VOL FT <sup>3</sup>
		H	W	D		
BLSLF1324MN	477	14.62	23.87	13.5	39.3	2.7
BLSLF1330MN	488	14.62	29.87	13.5	44.3	3.4
BLSLF1336MN	541	14.62	35.87	13.5	49.3	4.1
BLSLF1342MN	591	14.62	41.87	13.5	54.3	4.8
BLSLF1348MN	640	14.62	47.87	13.5	59.3	5.5
BLSLF1354MN	686	14.62	53.87	13.5	64.3	6.2
BLSLF1360MN	736	14.62	59.87	13.5	69.3	6.8
BLSLF1624MN	762	14.62	23.87	16.5	38.6	3.4
BLSLF1630MN	785	14.62	29.87	16.5	43.9	4.2
BLSLF1636MN	824	14.62	35.87	16.5	49.2	5.0
BLSLF1642MN	877	14.62	41.87	16.5	54.5	5.8
BLSLF1648MN	935	14.62	47.87	16.5	59.8	6.7
BLSLF1654MN	987	14.62	53.87	16.5	65.1	7.5
BLSLF1660MN	1028	14.62	59.87	16.5	70.4	8.4

**BSADA-PM • Panel-Mounted Overhead Storage Unit - AODA Compliant**

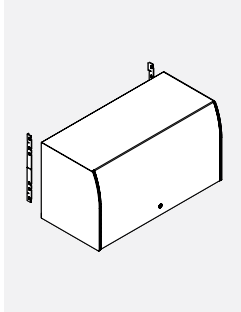

- Panel-mounted metal overhead storage with opaque acrylic door. The mechanism lifts the door up and stores it out of the way, above the storage unit.
- Meets CSA B651 Barrier Free Design and AODA (Accessibility for Ontarians with Disabilities Act).
- 16" high units accept standard and A4 binders.
- All shelves are reinforced for proper weight distribution.
- Inside dimensions: 14.25" high x 13.4" deep.
- Unit includes attachment hardware, lock and mounting brackets.
- Back not included.
- Not recommended for use with wall rails.
- Unit can be converted to up-mount overhead storage unit in the field by adding BSADAxxKIT.
- Shipped partially assembled.

PRODUCT CODE	PRICE	SIZE/INCHES			WEIGHT LBS	VOL FT <sup>3</sup>
		H	W	D		
BSADA24PM	955	16	24	14.2	22	4.3
BSADA30PM	1066	16	30	14.2	27	5.3
BSADA36PM	1144	16	36	14.2	32	6.3
BSADA42PM	1227	16	42	14.2	37	7.3
BSADA48PM	1309	16	48	14.2	42	8.3
BSADA54PM	1392	16	54	14.2	47	9.3
BSADA60PM	1471	16	60	14.2	53	10.3

**BSADA-UM • Up-Mounted Overhead Storage Unit - AODA Compliant**

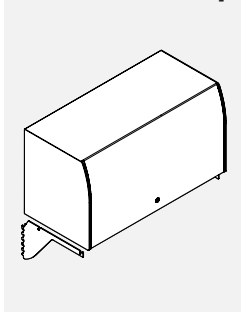

- Up-mounted storage can reduce furniture costs by reducing the height of all panels to 50". Complete 50" panel installations simplify cable routing at one level, within the top lay-in channel. Up-mounted cantilevers maintain accessibility and functionality of the panels' top lay-in channel.
- Meets CSA B651 Barrier Free Design & AODA (Accessibility for Ontarians with Disabilities Act).
- 16" high units accept standard and A4 binders.
- All shelves are reinforced for proper weight distribution.
- Inside dimensions: 14.25" high x 13.4" deep.
- Unit includes attachment hardware, lock, mounting cantilevers and has a finished back.
- Unit can be converted to a panel mounted overhead storage unit in the field by adding BSADAPMxxKIT.
- Shipped partially assembled.

PRODUCT CODE	PRICE	SIZE/INCHES			WEIGHT LBS	VOL FT <sup>3</sup>
		H	W	D		
BSADA24UM	1170	16	24	14.2	25	4.3
BSADA30UM	1264	16	30	14.2	33	5.3
BSADA36UM	1523	16	36	14.2	40	6.3
BSADA42UM	1604	16	42	14.2	46	7.3
BSADA48UM	1691	16	48	14.2	53	8.3
BSADA54UM	1775	16	54	14.2	59	9.3
BSADA60UM	1876	16	60	14.2	66	10.3

**BSADA-KIT • Up-Mounted Conversion Kit**

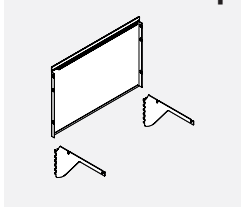

- Converts an existing panel mounted overhead storage unit BSADA-PM to an up-mounted overhead storage unit BSADA-UM.
- When used on a 50" high panel, the top of the overhead will match the height of 66" high panels.
- Kit includes a back panel for the overhead and up-mount cantilevers.

PRODUCT CODE	PRICE	SIZE/INCHES			WEIGHT LBS	VOL FT <sup>3</sup>
		H	W	D		
BSADA24KIT	237	16	24	2	6	0.6
BSADA30KIT	255	16	30	2	8	0.6
BSADA36KIT	268	16	36	2	10	0.7
BSADA42KIT	283	16	42	2	11	0.8
BSADA48KIT	300	16	48	2	13	0.9
BSADA54KIT	312	16	54	2	14	1.0
BSADA60KIT	327	16	60	2	15	1.1

**BSADA-OMKIT • Off-Module Conversion Kit**

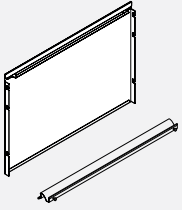

- Converts an existing panel mounted storage unit BSADA-PM to off-module overhead storage unit BSADA-OMKIT.
- Kit includes a back panel with integrated hanging bracket and an extruded bottom bracket.
- **IMPORTANT:** BSADA overhead with off-module conversion kit can only be installed on B3 fabric tile. Tiles below the overhead can be fabric, laminate and accessory tile. However, the tile the overhead is hanging on must be fabric.
- BSADA Overhead with off-module conversion kit can be suspended off of a single fabric tile, or can span two fabric tiles on two adjacent, directly interconnected panels.
- BSADA Overhead with off-module conversion kit **CANNOT** be suspended off of two panels separated by a post.

PRODUCT CODE	PRICE	SIZE/INCHES			WEIGHT VOL	
		H	W	D	LBS	FT <sup>3</sup>
BSADA240MKIT	235	16	24	2	6	0.5
BSADA300MKIT	237	16	30	2	8	0.6
BSADA360MKIT	247	16	36	2	10	0.7
BSADA420MKIT	260	16	42	2	11	0.8
BSADA480MKIT	273	16	48	2	13	0.9
BSADA540MKIT	289	16	54	2	14	1.0
BSADA600MKIT	302	16	60	2	15	1.1

**BSADA-KIT • Panel-Mounted Conversion Kit**



- Converts an existing up-mount overhead storage unit BSADA-UM to a Panel mounted overhead storage Unit BSADA-PM.
- Kit includes panel mounting brackets.

PRODUCT CODE	PRICE	SIZE/INCHES			WEIGHT VOL	
		H	W	D	LBS	FT <sup>3</sup>
BSADAPMKIT	101	16	0.5	2	2	0.009

**BSP1DO • Overhead Divider Storage for Boulevard 1 - Open Double-Sided**

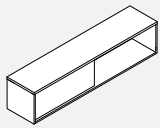

- Panel top mount allows access on both sides.
- Storage compartment internal height: 14".
- Overhead available in standard GC laminate finishes.
- Top mount on panels.
- Connecting hardware included.

PRODUCT CODE	PRICE		SIZE/INCHES			WEIGHT VOL	
	LP	HP	H	W	D	LBS	FT <sup>3</sup>
BSP1DO36	814	915	16	36	16	81	7
BSP1DO42	837	954	16	42	16	96	8
BSP1DO48	871	1003	16	48	16	100	9

**BSP1LDS • Overhead Divider Storage for Boulevard 1 - Open Double-Sided With Sliding Laminate Door**

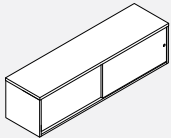

- Panel top mount allows access on both sides.
- Storage compartment internal height: 14".
- Overhead available in standard GC laminate finishes.
- Top mount on panels.
- Connecting hardware included.
- Sliding laminate doors are not locking.

PRODUCT CODE	PRICE		SIZE/INCHES			WEIGHT VOL	
	LP	HP	H	W	D	LBS	FT <sup>3</sup>
BSP1LDS36	2558	2659	16	36	16	87	7
BSP1LDS42	2618	2737	16	42	16	103	8
BSP1LDS48	2652	2787	16	48	16	108	9

**BSP1GDS • Overhead Divider Storage for Boulevard 1 - Open Double-Sided With Sliding Glass Door**

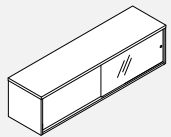

- Panel top mount allows access on both sides.
- Storage compartment internal height: 14".
- Overhead available in standard GC laminate finishes.
- Top mount on panels.
- Connecting hardware included.
- Sliding glass doors are not locking.

PRODUCT CODE	PRICE		SIZE/INCHES			WEIGHT VOL	
	LP	HP	H	W	D	LBS	FT <sup>3</sup>
BSP1GDS36	2650	2752	16	36	16	92	7
BSP1GDS42	2694	2813	16	42	16	108	8
BSP1GDS48	2733	2868	16	48	16	113	9

**BSP3DO • Overhead Divider Storage for Boulevard System 3 - Open Double-Sided**

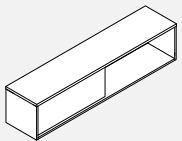

- Panel top mount allows access on both sides.
- Storage compartment internal height: 14".
- Overhead available in standard GC laminate finishes.
- Top mount on panels.
- Connecting hardware included.

PRODUCT CODE	PRICE		SIZE/INCHES			WEIGHT VOL	
	LP	HP	H	W	D	LBS	FT <sup>3</sup>
BSP3DO36	790	892	16	36	16	81	9
BSP3DO42	823	943	16	42	16	96	10.5
BSP3DO48	858	993	16	48	16	100	12

**BSP3LDS • Overhead Divider Storage for Boulevard System 3 - Open Double-Sided With Sliding Laminate Door**

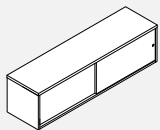

- Panel top mount allows access on both sides.
- Storage compartment internal height: 14".
- Overhead available in standard GC laminate finishes.
- Top mount on panels.
- Connecting hardware included.
- Sliding laminate doors are not locking.

PRODUCT CODE	PRICE		SIZE/INCHES			WEIGHT VOL	
	LP	HP	H	W	D	LBS	FT <sup>3</sup>
BSP3LDS36	2533	2635	16	36	16	106	7
BSP3LDS42	2596	2713	16	42	16	126	8
BSP3LDS48	2628	2763	16	48	16	134	9

**BSP3GDS • Overhead Divider Storage for Boulevard System 3 - Open Double-Sided With Sliding Glass Door**

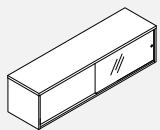

- Panel top mount allows access on both sides.
- Storage compartment internal height: 14".
- Overhead available in standard GC laminate finishes.
- Top mount on panels.
- Connecting hardware included.
- Sliding glass doors are not locking.

PRODUCT CODE	PRICE		SIZE/INCHES			WEIGHT VOL	
	LP	HP	H	W	D	LBS	FT <sup>3</sup>
BSP3GDS36	2625	2726	16	36	16	87	6
BSP3GDS42	2670	2787	16	42	16	103	7
BSP3GDS48	2709	2843	16	48	16	107	9

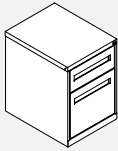

**BS93FPxxBFC • 9300 Series Freestanding Box/File Pedestal**

- One box and one file drawer pedestal.
- Freestanding, counterweight included.
- All drawers are locking.
- Box drawer includes pencil tray.

PRODUCT CODE	PRICE	SIZE / INCHES			WEIGHT LBS	VOL FT <sup>3</sup>
		H	W	D		
BS93FP19BFC	567	21.31	15	19	50	5.1
BS93FP23BFC	574	21.31	15	23	55	6.0
BS93FP29BFC	649	21.31	15	29	64	7.5

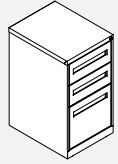
**BS93FPxxBBFC • 9300 Series Freestanding Box/Box/File Pedestal**

- Two box and one file drawer pedestal.
- Freestanding, counterweight included.
- All drawers are locking.
- Top box drawer includes pencil tray.

PRODUCT CODE	PRICE	SIZE / INCHES			WEIGHT LBS	VOL FT <sup>3</sup>
		H	W	D		
BS93FP19BBFC	631	27.87	15	19	55	6.5
BS93FP23BBFC	640	27.87	15	23	68	7.7
BS93FP29BBFC	704	27.87	15	29	78	9.6

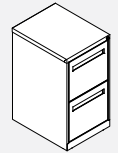
**BS93FPxxFFC • 9300 Series Freestanding File/File Pedestal**

- Two file drawer pedestal.
- Freestanding, counterweight included.
- All drawers are locking.

PRODUCT CODE	PRICE	SIZE / INCHES			WEIGHT LBS	VOL FT <sup>3</sup>
		H	W	D		
BS93FP19FFC	631	27.87	15	19	53	6.5
BS93FP23FFC	640	27.87	15	23	60	7.7
BS93FP29FFC	704	27.87	15	29	70	9.6

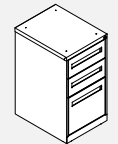
**BS93WPxxBBFC • 9300 Series Worksurface Supporting Box/Box/File Pedestal**

- Two box and one file drawer pedestal.
- Worksurface supporting, includes mounting holes in the top.
- All drawers are locking.
- Top box drawer includes pencil tray.
- Includes filler and brackets.

PRODUCT CODE	PRICE	SIZE / INCHES			WEIGHT LBS	VOL FT <sup>3</sup>
		H	W	D		
BS93WP19BBFC	631	27.87	15	19	55	6.5
BS93WP23BBFC	640	27.87	15	23	68	7.7
BS93WP29BBFC	704	27.87	15	29	78	9.6

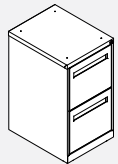
**BS93WPxxFFC • 9300 Series Worksurface Supporting File/File Pedestal**

- Two file drawer pedestal.
- Worksurface supporting, includes mounting holes in the top.
- All drawers are locking.
- Includes filler and brackets.

PRODUCT CODE	PRICE	SIZE / INCHES			WEIGHT LBS	VOL FT <sup>3</sup>
		H	W	D		
BS93WP19FFC	631	27.87	15	19	53	6.5
BS93WP23FFC	640	27.87	15	23	60	7.7
BS93WP29FFC	704	27.87	15	29	70	9.6

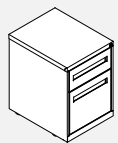
**BS93MPxxBFC • 9300 Series Mobile Box/File Pedestal**

- One box and one file drawer mobile pedestal.
- Casters pre-installed, casters non-locking.
- Counterweight included.
- All drawers locking.
- Box drawer includes pencil tray.
- NOTE: Cannot be used as guest seating.

PRODUCT CODE	PRICE	SIZE / INCHES			WEIGHT LBS	VOL FT <sup>3</sup>
		H	W	D		
BS93MP19BFC	748	21.87	15	19	66	5.2
BS93MP23BFC	756	21.87	15	23	72	6.2
BS93MP29BFC	869	21.87	15	29	92	7.6

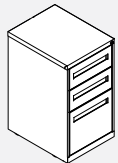
**BS93MPxxBBFC • 9300 Series Mobile Box/Box/File Pedestal**

- Two box and one file drawer mobile pedestal.
- Casters pre-installed, casters non-locking.
- Counterweight included.
- All drawers locking.
- Top box drawer includes pencil tray.
- NOTE: Cannot be used as guest seating.

PRODUCT CODE	PRICE	SIZE / INCHES			WEIGHT LBS	VOL FT <sup>3</sup>
		H	W	D		
BS93MP19BBFC	789	27.93	15	19	76	6.5
BS93MP23BBFC	803	27.93	15	23	85	7.7
BS93MP29BBFC	813	27.93	15	29	94	9.6

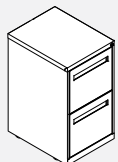
**BS93MPxxFFC • 9300 Series Mobile File/File Pedestal**

- Two file drawer pedestal.
- Casters pre-installed, casters non-locking.
- Counterweight included.
- All drawers locking.
- NOTE: Cannot be used as guest seating.

PRODUCT CODE	PRICE	SIZE / INCHES			WEIGHT LBS	VOL FT <sup>3</sup>
		H	W	D		
BS93MP19FFC	789	27.93	15	19	73	6.5
BS93MP23FFC	803	27.93	15	23	81	7.7
BS93MP29FFC	813	27.93	15	29	90	9.6

**BSPFOBFxxC • Prime Box/File Pedestal**



- One box and one file drawer pedestal.
- All drawers are locking.
- Box drawer includes pencil tray.
- For freestanding, to add counterweight (W2 option), add \$50 list.
- For mobile to add casters and counterweight (W1 option), add \$75 list. Adds 0.5" to height.
- NOTE: Cannot be used as guest seating.

PRODUCT CODE	PRICE	SIZE/INCHES			WEIGHT VOL	
		H	W	D	LBS	FT <sup>3</sup>
BSPFOBF18C	567	20.8	15	18	52.4	4.2
BSPFOBF22C	574	20.8	15	22	58.8	5.0
BSPFOBF28C	649	20.8	15	28	68.7	6.3

**BSPFSBGxxC • Prime Box/Box/File Pedestal**



- Two box and one file drawer pedestal.
- All drawers are locking.
- Top box drawer includes pencil tray.
- For freestanding, to add counterweight (W2 option), add \$50 list.
- For mobile to add casters and counterweight (W1 option), add \$75 list. Adds 0.5" to height.
- Top box drawer 4.8" high; middle box drawer 6.4" high; bottom file drawer 13.6" high (interior 12.5" high).
- When worksurface supporting option selected, unit includes pre-drilled top holes for attaching and filler/brackets.

PRODUCT CODE	PRICE	SIZE/INCHES			WEIGHT VOL	
		H	W	D	LBS	FT <sup>3</sup>
BSPFSBG18C	631	28	15	18	67.5	5.5
BSPFSBG22C	640	28	15	22	75.0	6.6
BSPFSBG28C	704	28	15	28	86.8	8.3

**BSPFOFGxxC • Prime File/File Pedestal**

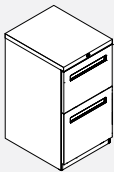

- Two file drawer pedestal.
- All drawers are locking.
- For freestanding, to add counterweight (W2 option), add \$50 list.
- For mobile to add casters and counterweight (W1 option), add \$75 list. Adds 0.5" to height.
- Top file drawer 11.2" high (interior 10.6" high); bottom file drawer 13.6" high (interior 12.5" high).
- When worksurface supporting option selected, unit includes pre-drilled top holes for attaching and filler/brackets.

PRODUCT CODE	PRICE	SIZE/INCHES			WEIGHT VOL	
		H	W	D	LBS	FT <sup>3</sup>
BSPFOFG18C	631	28	15	18	67.5	5.5
BSPFOFG22C	640	28	15	22	75.0	6.6
BSPFOFG28C	704	28	15	28	86.8	8.3

**BSPWOBFxxC • Prime Mobile Box/File Pedestal**



- Mobile one box and one file drawer pedestal.
- All drawers are locking.
- 60 mm casters.

PRODUCT CODE	PRICE	SIZE/INCHES			WEIGHT VOL	
		H	W	D	LBS	FT <sup>3</sup>
BSPWOBF18C	748	23.3	15	18	73.5	4.6
BSPWOBF22C	756	23.3	15	22	79.1	5.6
BSPWOBF28C	869	23.3	15	28	87.7	7.0

**BSTC • Pedestal/Lateral Seat Cushion**

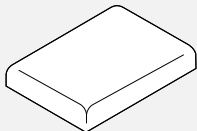

PRODUCT CODE	YRDS	SIZE/INCHES			WEIGHT VOL	
		H	W	D	LBS	FT <sup>3</sup>
BSTCP1518	0.75	2	15	18	5.00	0.41
BSTCP1522	0.75	2	15	22	5.25	0.45
BSTCP1528	1.00	2	15	28	5.5	0.55
BSTCL1830	1.00	2	18	30	6.0	0.55
BSTCL1836	1.25	2	18	36	6.5	0.65

PRODUCT CODE	PRICE									
	GR1	GR2	GR3	GR4	GR5	GR6	GR7	GR8	GR9	GR10
BSTCP1518	330	363	403	462	518	575	624	684	744	822
BSTCP1522	355	386	426	486	543	598	648	707	767	845
BSTCP1528	447	487	540	620	695	769	838	914	993	1097
BSTCL1830	469	512	563	644	719	792	861	938	1018	1122
BSTCL1836	559	615	679	779	872	966	1049	1146	1246	1375

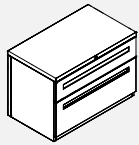
**BSLPS0BF18xxC • Prime Box/File Lateral File**

- One and a half height lateral filing cabinet.
- Fixed-front drawers; top box drawer front 4.8" high; bottom file drawer front 13.6" high (interior 12.5" high).
- Locking.
- Side-to-side hanging bars included.
- To add counterweight (W2 option), add \$410 list.

PRODUCT CODE	PRICE	SIZE/INCHES			WEIGHT LBS	VOL FT <sup>3</sup>
		H	W	D		
BSLPS0BF1830C	1257	20.98	30	18.06	119.96	8.0
BSLPS0BF1836C	1306	20.98	36	18.06	129.86	9.5
BSLPS0BF1842C	1350	20.98	42	18.06	165.45	11.1

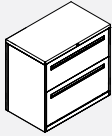
**BSLF20G18xxC • Prime 2-High Lateral File**

- Two-high lateral filing cabinet.
- Fixed-front file drawers; top drawer front 11.2" high (interior 10.6" high); bottom drawer front 13.6" high (interior 12.5" high).
- Locking.
- Side-to-side hanging bars included.
- To add counterweight (W2 option), add \$200 list.

PRODUCT CODE	PRICE	SIZE/INCHES			WEIGHT LBS	VOL FT <sup>3</sup>
		H	W	D		
BSLF20G1830C	1257	28	30	18	98.7	10.5
BSLF20G1836C	1314	28	36	18	114.4	12.5
BSLF20G1842C	12387	28	42	18	129.4	14.5

**BSLF30G18xxC • Prime 3-High Lateral File**

- Three-high lateral filing cabinet.
- Fixed-front file drawers; top and middle drawer front 11.2" high (interior 10.6" high); bottom drawer front 13.6" high (interior 12.5" high).
- Locking.
- Side-to-side hanging bars included.
- Will not line up with 42" high panels.
- To add counterweight (W2 option), add \$200 list.

PRODUCT CODE	PRICE	SIZE/INCHES			WEIGHT LBS	VOL FT <sup>3</sup>
		H	W	D		
BSLF30G1830C	1648	39.2	30	18	127.9	14.5
BSLF30G1836C	1733	39.2	36	18	147.6	17.2
BSLF30G1842C	1832	39.2	42	18	167.5	20.0

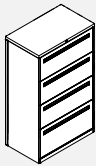
**BSLF40H18xxC • Prime 4-High File/File/File/File Lateral File**

- Four-high fixed-front lateral filing cabinet.
- Fixed-front file drawers; top drawer front 10.4" high (interior 9.8" high); second and third drawers 11.2" high (interior 10.6" high); bottom drawer front 13.6" high (interior 12.5" high).
- Locking.
- Side-to-side hanging bars included.
- To add counterweight (W2 option), add \$200 list.

PRODUCT CODE	PRICE	SIZE/INCHES			WEIGHT LBS	VOL FT <sup>3</sup>
		H	W	D		
BSLF40G1830C	1902	49.6	30	18	159.1	18.2
BSLF40G1836C	1998	49.6	36	18	183.4	21.6
BSLF40G1842C	2119	49.6	42	18	208.5	25.1

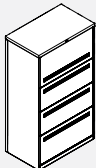
**BSLF40H18xxC • Prime 4-High Receding Top Door/File/File/File Lateral File**

- Four-high receding-top door and remaining fixed-front lateral filing cabinet.
- Top-opening receding door + roll-out shelf 14.4" high front, accepts binder height; fixed-front second and third drawers 11.2" high (interior 10.6" high); bottom drawer front 13.6" high (interior 12.5" high).
- Locking.
- Side-to-side hanging bars included.
- To add counterweight (W2 option), add \$200 list.

PRODUCT CODE	PRICE	SIZE/INCHES			WEIGHT LBS	VOL FT <sup>3</sup>
		H	W	D		
BSLF40H1830C	2091	53.6	30	18	171.9	19.6
BSLF40H1836C	2204	53.6	36	18	198.2	23.3
BSLF40H1842C	2333	53.6	42	18	225.3	27.0

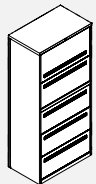
**BSLF50P18xxC • Prime 5-High Receding Top Door/File/File/File/File Lateral File**

- Five-high receding-top door and remaining fixed-front lateral filing cabinet.
- Locking.
- Side-to-side hanging bars included.
- Top-opening receding door + roll-out shelf 14.4" high front, accepts binder height; bottom fixed-front second and third drawers 11.2" high (interior 10.6" high); bottom drawer front 13.6" high (interior 12.5" high).
- To add counterweight (W2 option), add \$200 list.

PRODUCT CODE	PRICE	SIZE/INCHES			WEIGHT LBS	VOL FT <sup>3</sup>
		H	W	D		
BSLF50P1830C	2588	65.6	30	18	208.9	23.9
BSLF50P1836C	2694	65.6	36	18	239.9	28.4
BSLF50P1842C	2843	65.6	42	18	272.7	32.9

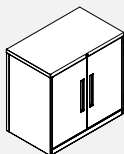
**BSSC21G18xxC • Prime 2 High Storage Cabinet**

- Two-high storage cabinet.
- One adjustable shelf + fixed bottom shelf.
- Locking.

PRODUCT CODE	PRICE	SIZE/INCHES			WEIGHT LBS	VOL FT <sup>3</sup>
		H	W	D		
BSSC21G1830C	1030	28	30	18	75.08	10.5
BSSC21G1836C	1150	28	36	18	86.48	12.5
BSSC21G1842C	1253	28	42	18	95.78	14.5

**BSSC31G18xxC • Prime 3-High Storage Cabinet**

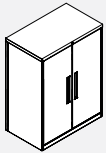

- Three-high storage cabinet.
- Two adjustable shelves + fixed bottom shelf.
- Will not line up to 42" high panels.
- Locking.

PRODUCT CODE	PRICE	SIZE/INCHES			WEIGHT		VOL FT <sup>3</sup>
		H	W	D	LBS		
BSSC31G1830C	1314	39.2	30	18	96.69		14.5
BSSC31G1836C	1442	39.2	36	18	111.59		17.2
BSSC31G1842C	1597	39.2	42	18	124.49		20.0

**BSSC41G18xxC • Prime 4-High Storage Cabinet**

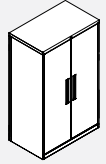

- Three-high storage cabinet to line up to 50" high panels.
- Three adjustable shelves + fixed bottom shelf.
- Locking.

PRODUCT CODE	PRICE	SIZE/INCHES			WEIGHT		VOL FT <sup>3</sup>
		H	W	D	LBS		
BSSC41G1830C	1543	49.6	30	18	111.22		18.2
BSSC41G1836C	1653	49.6	36	18	129.32		21.6
BSSC41G1842C	1829	49.6	42	18	145.42		25.1

**BSSC41H18xxC • Prime 4-High Storage Cabinet**

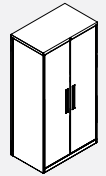

- Four-high storage cabinet.
- Three adjustable shelves + fixed bottom shelf.
- Locking.

PRODUCT CODE	PRICE	SIZE/INCHES			WEIGHT		VOL FT <sup>3</sup>
		H	W	D	LBS		
BSSC41H1830C	1640	53.6	30	18	120.17		19.6
BSSC41H1836C	1719	53.6	36	18	138.27		23.3
BSSC41H1842C	1902	53.6	42	18	154.37		27.0

**BSSC51C18xxC • Prime 5-High Storage Cabinet**

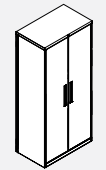

- Five high storage cabinet.
- Four adjustable shelves + fixed bottom shelf.
- Locking.

PRODUCT CODE	PRICE	SIZE/INCHES			WEIGHT		VOL FT <sup>3</sup>
		H	W	D	LBS		
BSSC51C1830C	1835	65.6	30	18	138.5		23.9
BSSC51C1836C	1946	65.6	36	18	160.4		28.4
BSSC51C1842C	2156	65.6	42	18	180.4		32.9

**BSSLFxx24BCCL • Prime Tower With Left Wardrobe, Half-Height Door and Box/Box/File Drawers**

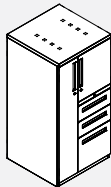

"4G" Tower Shown

- Left wardrobe tower with half-height door and box/box/file drawers.
- Wardrobe section includes top shelf and coat bar.
- Hinged-door compartment of 50" high and 54" high includes one adjustable shelf; 66" high includes two adjustable open shelves.
- Wardrobe section includes top perforations for ventilation.
- Three locks included – wardrobe door, hinged-door shelving compartment and drawers.
- To add counterweight (W2 option), add \$105 list.

PRODUCT CODE	PRICE	SIZE/INCHES			WEIGHT		VOL FT <sup>3</sup>
		H	W	D	LBS		
BSSLF4G24BCCL	2795	49.6	24	24	176.71		19.2
BSSLF4H24BCCL	2814	53.6	24	24	181.63		19.8
BSSLF5024BCCL	2940	65.6	24	24	204.52		25.2

**BSSLFxx24BCCR • Prime Tower With Right Wardrobe, Half-Height Door and Box/Box/File Drawers**

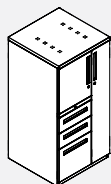

"4G" Tower Shown

- Right wardrobe tower with half-height door and box/box/file drawers.
- Wardrobe section includes top shelf and coat bar.
- Hinged-door compartment of 50" high and 54" high includes one adjustable shelf; 66" high includes two adjustable open shelves.
- Wardrobe section includes top perforations for ventilation.
- Three locks included – wardrobe door, hinged-door shelving compartment and drawers.
- To add counterweight (W2 option), add \$105 list.

PRODUCT CODE	PRICE	SIZE/INCHES			WEIGHT		VOL FT <sup>3</sup>
		H	W	D	LBS		
BSSLF4G24BCCR	2795	49.6	24	24	176.71		19.2
BSSLF4H24BCCR	2814	53.6	24	24	181.63		19.8
BSSLF5024BCCR	2940	65.6	24	24	204.52		25.2

**BSSLFxx24FCCL • Prime Tower With Left Wardrobe, Half-Height Door and File/File Drawers**

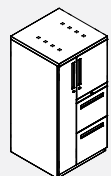

"4G" Tower Shown

- Left wardrobe tower with half-height door and file/file drawers.
- Wardrobe section includes top shelf and coat bar.
- Hinged-door compartment of 50" high and 54" high includes one adjustable shelf; 66" high includes two adjustable open shelves.
- Wardrobe section includes top perforations for ventilation.
- Three locks included – wardrobe door, hinged-door shelving compartment and drawers.
- To add counterweight (W2 option), add \$105 list.

PRODUCT CODE	PRICE	SIZE/INCHES			WEIGHT		VOL FT <sup>3</sup>
		H	W	D	LBS		
BSSLF4G24FCCL	2795	49.6	24	24	181.05		19.2
BSSLF4H24FCCL	2814	53.6	24	24	186.43		19.8
BSSLF5024FCCL	2940	65.6	24	24	231.53		25.2

**BSSLFxx24FCCR • Prime Tower With Right Wardrobe, Half-Height Door and File/File Drawers**

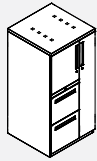

"4G" Tower Shown

- Right wardrobe tower with half-height door and file/file drawers.
- Wardrobe section includes top shelf and coat bar.
- Hinged-door compartment of 50" high and 54" high includes one adjustable shelf; 66" high includes two adjustable open shelves.
- Wardrobe section includes top perforations for ventilation.
- Three locks included – wardrobe door, hinged-door shelving compartment and drawers.
- To add counterweight (W2 option), add \$105 list.

PRODUCT CODE	PRICE	SIZE/INCHES			WEIGHT LBS	VOL FT <sup>3</sup>
		H	W	D		
BSSLF4G24FCCR	2795	49.6	24	24	181.05	19.2
BSSLF4H24FCCR	2814	53.6	24	24	186.43	19.8
BSSLF5024FCCR	2940	65.6	24	24	231.53	25.2

**BSSLSxx2424BOCL • Prime Tower With Left Wardrobe, Open Side Shelf, Box/Box/File Drawers**

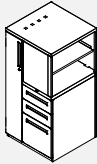

"4G" Tower Shown

- Left wardrobe tower with open side shelving and box/box/file drawers.
- Wardrobe section includes top shelf and coat bar.
- 50" high and 54" high include open side shelf with one adjustable shelf; 66" high includes open side shelf with two adjustable shelves.
- Wardrobe section includes top perforations for ventilation.
- Two locks included – wardrobe door and drawers.
- To add counterweight (W2 option), add \$105 list.

PRODUCT CODE	PRICE	SIZE/INCHES			WEIGHT LBS	VOL FT <sup>3</sup>
		H	W	D		
BSSLS4G2424BOCL	3089	49.6	24	24	186.18	19.2
BSSLS4H2424BOCL	3108	53.6	24	24	186.91	19.8
BSSLS502424BOCL	3157	65.6	24	24	236.34	25.2

**BSSLSxx2424BOCR • Prime Tower With Right Wardrobe, Open Side Shelf and Box/Box/File Drawers**

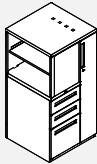

"4G" Tower Shown

- Right wardrobe tower with open side shelving and box/box/file drawers.
- Wardrobe section includes top shelf and coat bar.
- 50" high and 54" high include open side shelf with one adjustable shelf; 66" high includes open side shelf with two adjustable shelves.
- Wardrobe section includes top perforations for ventilation.
- Two locks included – wardrobe door and drawers.
- To add counterweight (W2 option), add \$105 list.

PRODUCT CODE	PRICE	SIZE/INCHES			WEIGHT LBS	VOL FT <sup>3</sup>
		H	W	D		
BSSLS4G2424BOCR	3089	49.6	24	24	186.18	19.2
BSSLS4H2424BOCR	3108	53.6	24	24	186.91	19.8
BSSLS502424BOCR	3157	65.6	24	24	236.34	25.2

**BSSLSxx2424FOCL • Prime Tower With Left Wardrobe, Open Side Shelf and File/File Drawers**

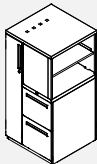

"4G" Tower Shown

- Left wardrobe tower with open side shelving and file/file drawers.
- Wardrobe section includes top shelf and coat bar.
- 50" high and 54" high include open side shelf with one adjustable shelf; 66" high includes open side shelf with two adjustable shelves.
- Wardrobe section includes top perforations for ventilation.
- Two locks included – wardrobe door and drawers.
- To add counterweight (W2 option), add \$105 list.

PRODUCT CODE	PRICE	SIZE/INCHES			WEIGHT LBS	VOL FT <sup>3</sup>
		H	W	D		
BSSLS4G2424FOCL	3089	49.6	24	24	179.54	19.2
BSSLS4H2424FOCL	3108	53.6	24	24	180.26	19.8
BSSLS502424FOCL	3157	65.6	24	24	232.55	25.2

**BSSLSxx2424FOCR • Prime Tower With Right Wardrobe, Open Side Shelf, File/File Drawers**

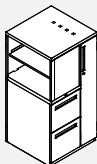

"4G" Tower Shown

- Right wardrobe tower with open side shelving and file/file drawers.
- Wardrobe section includes top shelf and coat bar.
- 50" high and 54" high include open side shelf with one adjustable shelf; 66" high includes open side shelf with two adjustable shelves.
- Wardrobe section includes top perforations for ventilation.
- Two locks included – wardrobe door and drawers.
- To add counterweight (W2 option), add \$105 list.

PRODUCT CODE	PRICE	SIZE/INCHES			WEIGHT LBS	VOL FT <sup>3</sup>
		H	W	D		
BSSLS4G2424FOCR	3089	49.6	24	24	179.54	19.2
BSSLS4H2424FOCR	3108	53.6	24	24	180.26	19.8
BSSLS502424FOCR	3157	65.6	24	24	232.55	25.2

**BSWC51C18xxC • Prime Wardrobe**

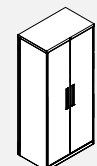

- Wardrobe cabinet.
- 30" wide includes full-width shelf and side-to-side coat rod.
- 36" wide and 42" wide are split with shelving on left side, wardrobe on the other.
- Locking.

PRODUCT CODE	PRICE	SIZE/INCHES			WEIGHT LBS	VOL FT <sup>3</sup>
		H	W	D		
BSWC51C1830C	1774	65.6	30	18	125.26	23.8
BSWC51C1836C	1981	65.6	36	18	164.97	28.4
BSWC51C1842C	2177	65.6	42	18	180.59	32.9

**BSCC31G18xxC • Prime 3-High Combination Cabinet**

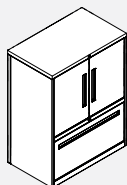

- Multi storage cabinet including hinged-door upper section with one adjustable shelf; one fixed front file drawers below.
- Will not line up to 42" panels.
- Locking.
- To add counterweight (W2 option), add \$200 list.

PRODUCT CODE	PRICE	SIZE/INCHES			WEIGHT LBS	VOL FT <sup>3</sup>
		H	W	D		
BSCC31G1830C	2178	39.2	30	18	117.3	14.5
BSCC31G1836C	2376	39.2	36	18	135.5	17.2
BSCC31G1842C	2581	39.2	42	18	152.5	20.0

**BSCC41G18xxC • Prime 4-High Combination Cabinet**

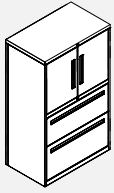

- Multi storage cabinet including hinged-door upper section with one adjustable shelf; two fixed-front file drawers below, lines up to 50" high panels.
- Locking.
- To add counterweight (W2 option), add \$200 list.

PRODUCT CODE	PRICE	SIZE/INCHES			WEIGHT LBS	VOL FT <sup>3</sup>
		H	W	D		
BSCC41G1830C	2642	49.6	30	18	149.96	18.2
BSCC41G1836C	2824	49.6	36	18	172.96	21.6
BSCC41G1842C	3045	49.6	42	18	195.36	25.1

**BSCC41H18xxC • Prime 4-High Combination Cabinet**

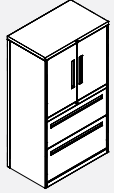

- Multi storage cabinet including hinged-door upper section with one adjustable shelf; two fixed-front file drawers below, lines up to 54" high panels.
- Locking.
- To add counterweight (W2 option), add \$200 list.

PRODUCT CODE	PRICE	SIZE/INCHES			WEIGHT LBS	VOL FT <sup>3</sup>
		H	W	D		
BSCC41H1830C	2772	53.6	30	18	154.54	19.6
BSCC41H1836C	2965	53.6	36	18	178.54	23.3
BSCC41H1842C	3196	53.6	42	18	202.04	27.0

**BSCC51C18xxC • Prime 5-High Combination Cabinet**

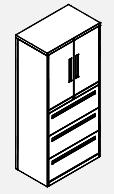

- Multi storage cabinet including hinged-door upper section with one adjustable shelf; three fixed-front file drawers below.
- Locking.
- To add counterweight (W2 option), add \$200 list.

PRODUCT CODE	PRICE	SIZE/INCHES			WEIGHT LBS	VOL FT <sup>3</sup>
		H	W	D		
BSCC51C1830C	3056	65.6	30	18	188.5	23.9
BSCC51C1836C	3274	65.6	36	18	216.9	28.4
BSCC51C1842C	3439	65.6	42	18	245.5	32.9

**BSLFA0718 • Prime Front-to-Back File Bars**

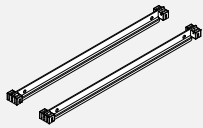

- Package of two, grey finish.

PRODUCT CODE	PRICE	SIZE/INCHES			WEIGHT LBS	VOL FT <sup>3</sup>
		H	W	D		
BSLFA0718	25	1	17.3	1	1	0.04

**BSLFS • Prime Hanging File Bars**

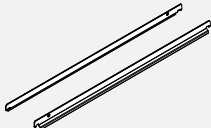

- Package of two, grey finish.

PRODUCT CODE	PRICE	SIZE/INCHES			WEIGHT LBS	VOL FT <sup>3</sup>
		H	W	D		
BSLFA01	43	1.3	27.5	0.5	2	0.03
BSLFA02	43	1.3	33.5	0.5	2.4	0.04
BSLFA03	43	1.3	39.5	0.5	2.8	0.05

**BSLFA1018 • Prime Plate Dividers**

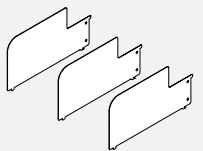

- Package of three, grey finish.

PRODUCT CODE	PRICE	SIZE/INCHES			WEIGHT LBS	VOL FT <sup>3</sup>
		H	W	D		
BSLFA1018	48	7.25	13.5	0.2	4	0.07

**BSLFA2418 • Prime Half-Height Plate Dividers**

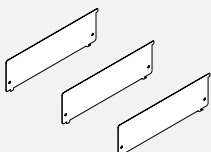

- Package of three, grey finish.

PRODUCT CODE	PRICE	SIZE/INCHES			WEIGHT LBS	VOL FT <sup>3</sup>
		H	W	D		
BSLFA2418	42	3.95	13.5	0.2	2.2	0.04

**BSLFA2018 • Prime EDP Adapters**

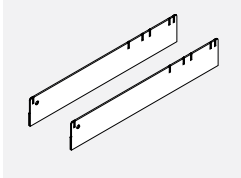

PRODUCT CODE	PRICE	SIZE/INCHES			WEIGHT LBS	VOL FT <sup>3</sup>
		H	W	D		
BSLFA2018	44	2.6	16.5	0.15	2.5	0.02

**BSK • Keys and Replacement Lock Core**

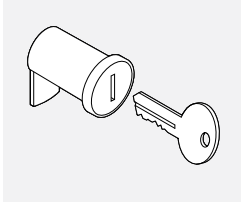

- Set of extra keys.
- Replacement lock and key.

PRODUCT CODE	PRICE	SIZE/INCHES			WEIGHT LBS	VOL FT <sup>3</sup>
		H	W	D		
BSKY -EXTRA KEY	12	1.75	0.75	0.2	0.2	0.01
BSKC - LOCK & KEY	39	2	1	0.5	0.4	0.01

**BSSA • Prime Extra Cabinet Shelves**

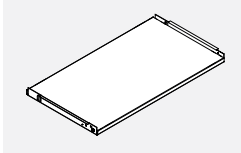

- Shelf, non-slotted.

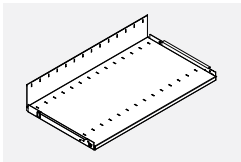

- Shelf, slotted.

PRODUCT CODE	PRICE	SIZE/INCHES			WEIGHT LBS	VOL FT <sup>3</sup>
		H	W	D		
Shelf, non-slotted.						
BSSA11830	120	0.8	28.4	16	7.2	1.8
BSSA11836	126	0.8	34.4	16	8.4	2.2
BSSA11842	134	0.8	40.4	16	9.5	2.6
Shelf, slotted.						
BSSA21830	130	5.25	28.4	16	8.2	1.8
BSSA21836	136	5.25	34.4	16	9.6	2.2
BSSA21842	148	5.25	40.4	16	10.8	2.6